



in co-operation with



PIANC

'Setting the Course'

Report n° 121 - 2014

A



B



HARBOUR APPROACH CHANNELS DESIGN GUIDELINES

The World Association for Waterborne Transport Infrastructure



PIANC

'Setting the course'

PIANC REPORT N° 121
MARITIME NAVIGATION COMMISSION

HARBOUR APPROACH CHANNELS DESIGN GUIDELINES

2014

PIANC has Technical Commissions concerned with inland waterways and ports (InCom), coastal and ocean waterways (including ports and harbours) (MarCom), environmental aspects (EnviCom) and sport and pleasure navigation (RecCom).

This report has been produced by an international Working Group convened by the Maritime Navigation Commission (MarCom). Members of the Working Group represent several countries and are acknowledged experts in their profession.

The objective of this report is to provide information and recommendations on good practice. Conformity is not obligatory and engineering judgement should be used in its application, especially in special circumstances. This report should be seen as an expert guidance and state of the art on this particular subject. PIANC disclaims all responsibility in case this report should be presented as an official standard.

PIANC Secrétariat Général
Boulevard du Roi Albert II 20, B 3
B-1000 Bruxelles
Belgique

<http://www.pianc.org>

VAT BE 408-287-945

ISBN 978-2-87223-210-9

© All rights reserved

Table of Contents

1	General Aspects	1
1.1	Scope	1
1.2	Introduction	1
	1.2.1 Terms of Reference.....	1
	1.2.1.1 Objective	1
	1.2.1.2 Matters Investigated.....	1
	1.2.2 Structure of Report.....	2
	1.2.3 Related PIANC Reports	2
	1.2.4 Members of the Working Group.....	2
	1.2.5 Meetings.....	3
	1.2.6 Acknowledgements.....	3
1.3	General Aspects of Channel Design	4
	1.3.1 Maritime Configuration of Ports.....	4
	1.3.2 Approach Channel Design Considerations.....	4
	1.3.3 Basic Definitions.....	5
	1.3.4 General Project Criteria	6
	1.3.4.1 Basic Criteria	6
	1.3.4.2 Elements Defining a Channel.....	6
	1.3.4.3 Types of Ships and Characteristics	6
	1.3.4.4 Limiting Operational Conditions.....	9
	1.3.4.5 Human Error and Project Uncertainties	10
	1.3.5 Physical Environment Data.....	10
	1.3.5.1 Data Requirements.....	10
	1.3.5.2 Physical Environment Issues.....	11
	1.3.5.3 Data Analysis and Modelling	12
	1.3.6 Elements of Channel Dimensions	12
	1.3.6.1 Channel Depth	12
	1.3.6.2 Channel Width.....	13
	1.3.6.3 Links between Vertical and Horizontal Dimensioning	13
	1.3.7 Design Verification Procedures	14
	1.3.7.1 Deterministic Verification	14
	1.3.7.2 Probabilistic Verification.....	14
	1.3.8 Safety Factors.....	14
1.4	Processes in Channel Design and Design Philosophy	15
	1.4.1 Design Process.....	15
	1.4.1.1 Concept Design.....	15
	1.4.1.2 Detailed Design	17
	1.4.2 Design Methodology	18
	1.4.2.1 The 'Design Ship' Concept	18
	1.4.2.2 Channel Depth, Width and Alignment	19
	1.4.2.3 Aids to Navigation.....	19
	1.4.3 Probability Aspects in the Design Process.....	19
	1.4.3.1 Marine Traffic and Risk Analysis.....	19
	1.4.3.2 Vertical Channel Dimensions.....	20
	1.4.3.3 Horizontal Channel Dimensions.....	20
	1.4.4 Risk Assessment	21
	1.4.5 Upgrading Existing Channels	21
2	Design of Vertical Channel Dimensions	22
2.1	Channel Depth Factors	23
	2.1.1 Water Level Factors.....	23
	2.1.1.1 Reference Level (Datum).....	23
	2.1.1.2 Design Water Level	24
	2.1.1.3 Tidal and Meteorological Effects	24
	2.1.2 Ship-Related Factors	25
	2.1.2.1 Static Draught.....	26
	2.1.2.2 Allowance for Static Draught Uncertainties.....	26
	2.1.2.3 Change in Water Density	26

2.1.2.4	Ship Squat.....	26
2.1.2.5	Dynamic Heel.....	30
2.1.2.6	Wave Response Allowance	30
2.1.2.7	Net UKC (UKC_{Net}).....	33
2.1.2.8	Manoeuvrability Margin (MM).....	33
2.1.3	Bottom-Related Factors	34
2.1.3.1	Allowance for Bed Level Uncertainties.....	34
2.1.3.2	Allowance for Bottom Changes between Dredging.....	34
2.1.3.3	Dredging Execution Tolerance.....	34
2.1.3.4	Muddy Channel Beds	34
2.2	Air Draught Clearance (ADC).....	36
2.3	Concept Design – Vertical Dimensions	37
2.3.1	Design Water Level.....	37
2.3.2	Ship-Related Factors (F_s).....	37
2.3.3	Air Draught Clearance (ADC)	38
2.3.4	Concept Design Example Problems	39
2.3.4.1	Example 1: Finland, General Cargo Ship	39
2.3.4.2	Example 2: Richards Bay, South Africa, Coal Bunker.....	40
2.3.4.3	Example 3: Zeebrugge, Belgium, Container Ship	40
2.3.4.4	Example 4: Panama Canal, Tanker.....	41
2.4	Detailed Design – Vertical Dimensions.....	42
2.4.1	Water Level Factors.....	42
2.4.2	Ship Factors	42
2.4.2.1	Squat (S_{Max}).....	42
2.4.2.2	Dynamic Heel (Z_{WR}).....	42
2.4.2.3	Wave Response Allowance (Z_{Max}).....	49
2.4.3	Bottom Factors	61
2.4.3.1	Allowance for Bed Level Uncertainties.....	61
2.4.3.2	Allowance for Bottom Changes between Dredging.....	61
2.4.3.3	Dredging Execution Tolerance.....	61
2.4.3.4	Muddy Channel Beds	61
2.4.4	Air Draught and ADC.....	61
2.5	Probabilistic Design Considerations	61
2.5.1	Criteria for Probability of Exceedance.....	62
2.5.2	Risk 63	
2.5.3	Long-Term Probability Criterion.....	64
2.5.4	Probabilistic Design	65
2.5.4.1	Monte Carlo Simulation Technique	66
2.5.4.2	Probabilistic Design Tools.....	66
2.5.5	Operational Channel Allowance	71
2.5.6	Tidal Window Design	72
3	CHANNEL WIDTH, HARBOUR ENTRANCES, MANOEUVRING AND ANCHORAGE AREAS.....	73
3.1	Concept Design - Horizontal Dimensions.....	74
3.1.1	Channel Width	74
3.1.1.1	Introduction to the Concept Design Method.....	75
3.1.2	Channel Alignment and Width Consideration.....	76
3.1.2.1	General	76
3.1.2.2	Bend Configuration.....	77
3.1.2.3	Basic Manoeuvrability.....	77
3.1.2.4	Environmental Forces.....	79
3.1.2.5	Visibility	81
3.1.2.6	Bank Clearance and Ship-Ship Interactions	81
3.1.2.7	Fairway Marking and Positioning Systems.....	82
3.1.3	Outer Exposed Channel and Inner Protected Channel.....	82
3.1.4	One- or Two-way Channels.....	82
3.1.4.1	Example 1	85
3.1.4.2	Example 2	85
3.1.5	Concept Design Methods for Straight Channels	86
3.1.5.1	Basic Manoeuvring Lane W_{BM}	86

3.1.5.2	Environmental and Other Factors W_i	86
3.1.5.3	Additional Width for Bank Clearance.....	89
3.1.5.4	Additional Width for Passing Distance in Two-Way Traffic.....	90
3.1.5.5	Additional Width for Large Tidal Range.....	90
3.1.6	Concept Design Methods for Curved Channels and Bends.....	90
3.1.6.1	Turning Radius and Swept Path.....	90
3.1.6.2	Additional Widths in Bends	92
3.1.7	Introduction to Spanish and Japanese Concept Design Standards for Channel Width	92
3.1.7.1	Spanish Recommendation for Maritime Works.....	92
3.1.7.2	Japanese Design Method	94
3.1.8	Harbour Entrances and Manoeuvring Areas	95
3.1.8.1	Introduction	95
3.1.8.2	Stopping Procedure and estimation of stopping distance	95
3.1.8.3	Harbour Entrance	97
3.1.8.4	Turning Basin	97
3.1.8.5	Clearance for Moored Ships	98
3.1.9	Anchorage Areas	100
3.1.9.1	Introduction	100
3.1.9.2	Design Factors	101
3.1.9.3	Anchorage Design for a Vessel with One Anchor Ahead.....	102
3.1.10	Pilot Boarding and Landing Areas	104
3.2	Detailed Design – Horizontal Dimensions	105
3.2.1	Motivation	105
3.2.2	Tools and Methods	105
3.2.2.1	Detailed Parametric Design and Special Formulae.....	105
3.2.2.2	Simulation Models	106
3.2.3	Ship Manoeuvring Simulation Models.....	106
3.2.3.1	Introduction	106
3.2.3.2	Fast-Time Simulation.....	107
3.2.3.3	Real-Time Simulation	108
3.2.4	Traffic Flow Simulation Models.....	109
3.2.4.1	System Boundaries	110
3.2.4.2	Model Description.....	110
3.2.4.3	Simulation Language.....	111
3.2.4.4	Verification and Validation	111
3.2.4.5	Capacity Estimation.....	111
3.2.5	Traffic Flow Simulation Model to Determine Capacity	112
3.2.5.1	Generator Component Process	113
3.2.5.2	Ship Class	113
3.2.5.3	Ship Length.....	113
3.2.5.4	Draught and Tidal Window.....	113
3.2.5.5	Destination in the Port and Incoming and Outgoing Routes.....	113
3.2.5.6	Separation Times	114
3.2.5.7	Inter-Arrival Time and Service Time Distribution.....	115
3.2.5.8	Ship Component Process	116
3.2.5.9	VTS Components Process.....	117
3.2.6	Traffic Flow Model to Determine Safety Levels.....	118
3.2.6.1	Introduction	118
3.2.6.2	Safety Domain.....	119
3.2.6.3	Vessel Paths	120
3.2.6.4	Evaluation of Simulation Results.....	121
4	OTHER ASPECTS	123
4.1	Risk Management and Analysis	123
4.1.1	General.....	123
4.1.2	Maritime Incidents.....	125
4.1.3	Types of Incidents.....	125
4.1.4	Risk Analysis Methodologies.....	126
4.1.5	Simplified Qualitative Matrix Method.....	126
4.2	Training	128

4.3	Operational Rules and Environmental Limits	129
4.3.1	General.....	129
4.3.2	Channels.....	129
4.3.3	Harbour Entrances.....	130
4.3.4	Stopping Areas.....	131
4.3.5	Turning Areas.....	132
4.3.6	Anchorage Areas.....	132
4.3.7	Moorings Areas and Buoy Systems.....	132
4.3.8	Basins and Quays.....	133
4.4	Winter Navigation and Channel Design	135
4.4.1	General.....	135
4.4.2	Factors Affecting the Design of a Channel for Winter Navigation.....	135
4.4.2.1	General Conditions.....	135
4.4.2.2	Alignment and Geometry.....	135
4.4.2.3	Channel Width.....	136
4.4.2.4	Channel Depth, Gross Underkeel Clearance.....	136
4.4.2.5	Channel Markings/Aids to Navigation.....	137
4.4.2.6	Harbour Basin.....	137
4.4.2.7	Pilotage.....	137
4.5	Environmental Issues	137
4.5.1	Regulations and Sustainability.....	138
4.5.2	Work on Channels and Dredged Materials Management.....	139
4.5.2.1	Dredge Planning Activities.....	139
4.5.2.2	Dredging.....	139
4.5.2.3	Disposal of Dredged Material.....	139
4.5.3	Biodiversity.....	140
4.6	Aids to Navigation (AtoN)	140
4.6.1	Channel Markings.....	141
4.6.2	On-Board Navigation Systems.....	142
4.6.2.1	Visual Navigation.....	142
4.6.2.2	Electronic Aids.....	142
4.6.3	VTS/VTMS Systems and Impact.....	143
4.6.4	Future Development of AtoN.....	144
5	REFERENCES	145
List of Appendices		
APPENDIX A TERMS OF REFERENCE		156
APPENDIX B GLOSSARY, ABBREVIATIONS AND SYMBOLS		159
B.1 GLOSSARY		159
B.2 ABBREVIATIONS		161
B.3 SYMBOLS		162
APPENDIX C TYPICAL SHIP DIMENSIONS		169
C.1 Typical Ship Dimensions from ROM 3.1		171
C.2 Japanese Statistical Analysis of Ship Dimensions		177
C.3 Relationship Between DWT and H_{kt}		179
C.4 Relationship Between C_B, Δ, Δ_m and ∇		180
C.5 Relationship Between Ship's Draught and Water Density		180
C.6 Japanese Metacentric Height Estimates		181
C.7 References		181
APPENDIX D PREDICTION OF SHIP SQUAT		182
D.1 Ship Characteristics		182
D.1.1 Dimensionless Parameters.....		182
D.1.2 Block Coefficient.....		183
D.1.3 Water Plane Cross-Sectional Area.....		183
D.1.4 Ship Speed.....		183
D.1.5 Calculated Ship Parameters.....		183
D.2 Channel Characteristics		184
D.2.1 Channel Types.....		184
D.2.2 Channel Parameters.....		185
D.3 Combined Ship and Channel Parameters		186

D.3.1 Relative Depth Ratio h/T	186
D.3.2 Blockage Factor S	186
D.3.3 Velocity Return Factor S_2	187
D.3.4 Depth Froude Number F_{nh}	187
D.3.5. Critical Speed in Canals V_{Cr}	187
D.4 Empirical Squat Formulas.....	188
D.4.1 Tuck (T).....	190
D.4.2 Huuska/Guliev (H).....	191
D.4.3 ICORELS (I).....	194
D.4.4 Barrass3 (B3).....	195
D.4.5 Eryuzlu2 (E2).....	196
D.4.6 Römisch (R).....	197
D.4.7 Yoshimura (Y).....	199
D.5 Example Problems.....	199
D.5.1 BAW Model Container Ship in Unrestricted Channel.....	199
D.5.2 SR108 Container Ship in Unrestricted Channel.....	201
D.5.3 FHR Model Container Ship in Restricted Channel.....	202
D.5.4 BAW Model Container Ship in Restricted Channel.....	204
D.5.5 <i>Esso France</i> Model Tanker in Suez Canal.....	205
D.5.6 Global Challenger Bulk Carrier in Panama Canal.....	207
D.6. Special Effects on Squat.....	208
D.6.1 Passing and Overtaking Ships.....	208
D.6.1.1 Head-On Passing Encounters.....	208
D.6.1.2 Overtaking Manoeuvres.....	209
D.6.2 Proximity of Channel Banks.....	209
D.6.3 Channel Bottom Configurations.....	210
D.6.4 Muddy Bottoms.....	210
D.6.5 Ship Stern Transoms.....	214
D.7 Numerical Modelling of Squat.....	215
D.7.1 Numerical Methods.....	215
D.7.1.1 Slender-Body Models.....	215
D.7.1.2 Boundary Element Models.....	215
D.7.1.3 Computational Fluid Dynamic (CFD) Models.....	216
D.7.2 Modelling System to Predict Ship Squat.....	217
D.7.3 Numerical Modelling Examples.....	217
D.7.3.1 BAW Model Container Ship in Unrestricted Channel.....	217
D.7.3.2 SR108 Container Ship in Unrestricted Channel.....	218
D.7.3.3 FHR Container Ship in Restricted Channel.....	218
D.7.3.4 <i>Esso France</i> Tanker in Suez Canal.....	218
D.7.3.5 <i>Global Challenger</i> Bulk Carrier in Canal.....	218
D.8 Future of Squat Research.....	218
APPENDIX E WATER DEPTHS IN MUDDY AREAS – THE NAUTICAL BOTTOM APPROACH	220
E.1 Introduction.....	220
E.2 Mud Characteristics.....	220
E.2.1 Rheology.....	220
E.2.2 Density.....	222
E.2.3 Density-Rheology Relationship.....	222
E.3 Criteria for Determining the Nautical Bottom.....	225
E.3.1 Echo-Sounding Criteria.....	225
E.3.2 Rheology-Related Criteria.....	227
E.3.3 Ship Behaviour Criteria.....	228
E.3.4 Mud Density Level Criteria.....	228
E.3.5 Actual Practice.....	229
E.3.5.1 Belgium.....	229
E.3.5.2 France.....	230
E.3.5.3 Germany.....	230
E.3.5.4 The Netherlands.....	230
E.3.5.5 United States.....	231
E.4 Behaviour of Ships in Muddy Areas.....	231
E.4.1 Causes of Changed Behaviour.....	231

E.4.2 Internal Undulations at the Interface (Internal Waves).....	231
E.4.3 Resistance and Propulsion.....	232
E.4.4 Manoeuvrability.....	233
APPENDIX F: AIR DRAUGHT	235
F.1 Introduction	235
F.2 Air Draught Clearance (ADC)	236
F.3 Concept Design	237
F.4 Detailed Design.....	237
F.4.1 Japanese Statistical Analysis of Air Draught H_{st}.....	237
F.4.2 Detailed Design of ADC.....	238
F.4.3 Comparison Ballast Draught with Appendix C.....	238
F.4.3.1 Oil Tanker, 300,000 DWT	238
F.4.3.2 Container Ship, 100,000 DWT	238
APPENDIX G: SPANISH AND JAPANESE METHODS FOR DESIGN OF CHANNEL WIDTH .	242
G1: SPANISH RECOMMENDATIONS FOR CONCEPT DESIGN WIDTH	243
G1.1 General Design Criteria.....	243
G1.1.1 Design Lifetime.....	243
G1.1.2 Elements Defining a Navigation Channel and Harbour Basin	244
G1.1.3 Design Criteria.....	244
G1.2 Horizontal Dimensioning of Channels and Harbour Basins.....	247
G1.2.1 Introduction.....	247
G1.2.2 General Criteria	247
G1.2.3 General Layout Recommendations	248
G1.2.4 Fairway Width.....	249
G1.2.4.1 General Criteria	249
G1.2.4.2 Determining Nominal Width B_n by the Deterministic Method.....	250
G1.2.4.3 Determining Nominal Width B_n by the Semi-Probabilistic Method.....	271
G1.2.5 Point of No Return	275
G2: JAPANESE NEW DESIGN METHOD OF FAIRWAY WIDTH DETERMINATION AT	
CONCEPT DESIGN	276
G2.1 Basic Formulae of Fairway Width Determination	276
G2.2 Ship Types.....	277
G2.3 Estimation of Fundamental Manoeuvring Lane	277
G2.3.1 Width Requisite against Wind and Current Forces	277
G2.3.1.1 Drift Angle due to Wind Forces	278
G2.3.1.2 Drift Angle due to Current Forces.....	279
G2.3.2 Width Requisite against Yawing Motion	279
G2.3.3 Width Requisite for Drift Detection	280
G2.3.3.1 Drift Detection by Observing Light Buoys with Naked Eye.....	281
G2.3.3.2 Drift Detection by Observing Light Buoys with RADAR.....	282
G2.3.3.3 Drift Detection by GPS.....	282
G2.4 Estimation of Additional Width for Interaction Forces	283
G2.4.1 Width Requisite against Bank Effect Forces.....	283
G2.4.2 Width Requisite against Two-Ship Interaction in Passing	285
G2.4.3 Width Requisite against Two-Ship Interaction in Overtaking.....	286
G2.5 Safety Factor Based on Risk Level	288
G2.6 Fairway Width Determination	288
G2.6.1 Determination Procedures	288
G2.6.2 Design Examples.....	289
G2.7 Bend Curvature Determination	293
G2.8 Calculation of Drift Angle due to Wind Forces (Addendum)	294
G2.8.1 Drift Angle and Check Helm.....	294
G2.8.2 Linear Derivatives of Hull Forces and Rudder Forces	294
G2.8.3 Wind Force Coefficients.....	295
G2.9 Calculation of Check Helm against Interaction Forces (Addendum).....	297
G2.9.1 Check Helm against Bank Effect Forces	297
G2.9.2 Check Helm against Two-Ship Interaction.....	298
G3: DETAILED JAPANESE FORMULAE ON WIND-WAVE-CURRENT EFFECTS VERSUS SHIP	
TYPE-SIZES	301
G3.1 Equations of Ship Manoeuvring Motion.....	301

G3.2 Wind Forces	302
G3.2.1 Representations of Wind Forces	302
G3.2.2 Estimations of Wind Force Coefficients	303
G3.3 Wave Forces	304
G3.3.1 Lateral Deviation due to Yawing Motion	304
G3.3.2 Representations of Wave Drifting Forces	305
G3.4 Current Forces	305
G3.5 Hull Forces and Rudder Forces.....	306
G3.5.1 Hull Forces	306
G3.5.2 Rudder Forces.....	306
G3.6 Linearised Motion Equations.....	307
G3.6.1 Linearisation of Hydrodynamic Forces	307
G3.6.2 Linearised Sway and Yaw Equations	308
G3.6.3 Estimation of Linear Hull Force Derivatives	308
G3.7 Drift Angle and Check Helm in Course Keeping Motion under Wind Forces	309
G3.7.1 Equilibrium Equations	309
G3.7.2 Drift Angle and Check Helm.....	309

1 GENERAL ASPECTS

1.1 Scope

This report provides guidelines and recommendations for the design of vertical and horizontal dimensions of harbour approach channels and the manoeuvring and anchorage areas within harbours, along with defining restrictions to operations within a channel. It includes guidelines for establishing depth and width requirements, along with vertical bridge clearances.

The report supersedes and replaces the joint PIANC-IAPH report 'Approach Channels – A Guide for Design' published in 1997 (PIANC MarCom Working Group 30) in cooperation with IAPH, IMPA and IALA. This report has been widely accepted worldwide by port designers. This new report has again been compiled in close co-operation with IAPH (International Association of Ports & Harbours), IMPA (International Maritime Pilots Association) and IALA (International Association of Marine Aids to Navigation and Lighthouse Authorities).

1.2 Introduction

1.2.1 Terms of Reference

The Terms of Reference set by the Maritime Commission of PIANC (MarCom) for Working Group 49 (WG 49) are given in Appendix A of this report and are summarised below.

1.2.1.1 Objective

The objectives of the Working Group were to review, update and, where appropriate, expand on the design recommendations on vertical and horizontal dimensioning as presented in the Working Group 30 report of 1997 on approach channels. Recent developments in ship design, better understanding of ship manoeuvrability and behaviour in waves and further research in ship simulation and modelling required a comprehensive update to the 1997 report.

1.2.1.2 Matters Investigated

The Working Group has paid particular attention to:

- Vertical motions of ships in approach channels (due to squat, wave-induced motions, dynamic effects, etc.)
- Air draught for vertical clearances under bridges, overhead cables, etc.
- Horizontal dimensions of channels and manoeuvring areas
- Simulation of ships in channels
- New and future generation ship dimensions/manoeuvring characteristics
- Wind effect on ship navigation and manoeuvring
- Human errors and project uncertainties
- Environmental issues
- Safety criteria, assessment of levels of risk and appropriate clearance margins

All sizes of approach channel for commercial shipping are considered in this report; the problems of catering for small coasters in a small port may be as great as those for a large tanker at an oil terminal.

1.2.2 Structure of Report

The structure of this report can be summarised as follows:

- Chapter 1 – Introduction: design processes, data, ship behaviour
- Chapter 2 – Design of vertical channel dimensions
- Chapter 3 – Design of horizontal channel dimensions and layout
- Chapter 4 – Other aspects

Chapters 2 and 3 each deal with two stages of channel design: Concept Design (1.4.1.1) followed by Detailed Design (1.4.1.2) processes. Additional data and details are included in Chapters 2 to 4 and Appendices A to G.

1.2.3 Related PIANC Reports

The following PIANC reports are also relevant to the design and operation of approach channels:

PIANC Report No.115	Criteria for (Un)loading of Container Ships	2012
PIANC Report No.117	Use of Hydro/Meteo Information to Optimise Safe Port Access	2012

The following PIANC reports are **superseded** and replaced by this WG49 Report and should be used only for historical reference purposes:

	Report published by Working Group 2 of the PIANC International Oil Tankers Commission (IOTC)	1972
	Working Group 4 of the PIANC International Commission for the Reception of Large Ships (ICORELS)	1980
MarCom WG 5	Underkeel Clearance for Large Ships in Maritime Fairways with Hard Bottom	Supplement to PIANC Bulletin 51, 1985
MarCom WG 30	Joint PIANC-IAPH report on Approach Channels – Preliminary Guidelines	Supplement to PIANC Bulletin 87, 1995
MarCom WG 30	Approach Channels – A Guide for Design	Supplement to PIANC Bulletin 95, 1997

1.2.4 Members of the Working Group

The Working Group comprised membership from PIANC, IAPH and IMPA. The WG was also attended by representatives from IALA. WG 49 consisted of the following members:

- Dr. Mark McBride, WG 49 Chairman, HR Wallingford Ltd., UK
- Martin Boll, Wasser-und Schifffahrtsdirektion Nord (WSV), Germany

- Dr. Michael J. Briggs, WG 49 Vertical Subgroup Leader, USACE Coastal and Hydraulics Laboratory, USA
- Larry Cao, Canadian Coast Guard, Canada
- Capt. Don Cockrill, IMPA and Port of London Authority (PLA), UK
- Dr. Pierre Debaillon, CETMEF/DRIM/LHN, France
- Werner Dietze (former Member of WG 30), formerly WSV, Germany
- Rink Groenveld (former Member of WG 30), WG 49 Horizontal Subgroup Leader, TU Delft, The Netherlands
- Jarmo Hartikainen, Finnish Transport Agency, Finland
- Jose Ramon Iribarren, Siport21, Spain
- Hans Moes, CSIR, South Africa
- Dr. Terry O'Brien, OMC International, Australia
- Dr. Kohei Otsu, Tokyo University of Marine Science & Technology, Japan
- Sahil Patel (Corresponding member), Prestedge Retief Dresner Wijnberg (Pty) Ltd., South Africa
- Carlos Sanchidrian Fernandez, PROES Consultores S.A., Spain
- Paul Scherrer, IAPH and Port of Le Havre, France
- Esa Sirkiä, Finnish Transport Agency, Finland
- Capt. Masanori Tsugane, Tokai University, School of Marine Science & Technology, Japan
- Dr. Wim van der Molen, CSIR, South Africa
- Jos van Doorn, Marin, The Netherlands
- Prof. Marc Vantorre (former Member of WG 30), Ghent University, Belgium (in co-operation with Flanders Hydraulics Research, Flemish Government – Department Mobility and Public Works, Belgium)

1.2.5 Meetings

A total of 14 meetings of the WG were held during the course of the project in Madrid, Brussels, Lisbon, Wallingford, Vicksburg, Antwerp, Wageningen, Le Havre, London (IMPA), Elsfleth, Stellenbosch, Wageningen, Brussels and London (IMPA and IALA).

1.2.6 Acknowledgements

We would like to acknowledge Peter Hunter, HR Wallingford, UK, our MarCom Contact, for his support and assistance in compiling and publishing this report.

The following individuals and organisations also contributed substantially to the successful completion of this report:

- Nick Dodson, IALA, UK
- Roger Barker, IALA, UK
- Hendrick Eusterbarkey, IALA, Germany
- Dr Masayoshi Hirano, Akishima Laboratories (Mitsui Zosen) Inc., Japan
- Teruhiko Kohama, Coastal Development Institute of Technology, Japan
- Takemasa Minemoto, Coastal Development Institute of Technology, Japan
- Stephen Cork, former Chairman of the PIANC UK Section, UK
- Ian A. Mathis, Institute for Water Resources (IWR), USA

1.3 General Aspects of Channel Design

1.3.1 Maritime Configuration of Ports

The maritime port configuration includes water areas that are part of the channel and its related navigational areas and must all be considered together to achieve a harmonised overall design. They can be classified into two groups:

- Moving vessel areas: those principally assigned to navigation of vessels (e.g. channels, harbour entrances, manoeuvring areas)
- Stationary vessel areas: those principally assigned to stationary vessels (e.g. anchorages, mooring areas, quays, berths, terminals)

Some element descriptions are as follows:

- Channels: clearly defined route within which vessel traffic is established
- Harbour entrances: the entry and exit zone to a port or terminal
- Manoeuvring areas: zones where a vessel stops or turns, or manoeuvres to berth
- Anchorages: areas with sufficient depth and conditions for a ship to be able to anchor safely

1.3.2 Approach Channel Design Considerations

Port planners generally seek to optimise the economics of the overall transport chain, including an acceptable return on investment in port infrastructure and equipment and compliance with any environmental criteria.

The pressure on port authorities to provide approach channels for larger ships, or to allow larger ships to use existing channels, is a result of the economics of shipping. The costs per tonne-km of cargo, with respect to fuel, crew, and capital value for a ship at sea, decrease as ship size increases.

Increases in ship size, once accepted, puts a premium on minimising time in port, which leads to further pressures on the approach channel design:

- To minimise ship transit time in the approach channel
- To provide accessibility at all stages of tide in all weathers, or at least to minimise restrictions

The development of a successful port is an on-going process, dependent on variations in both world trade and markets and on trends in shipping and cargo-handling practice. It is necessary for the port authority, therefore, to anticipate demand and trends, and to forecast the quantities of goods likely to pass through the port, and the ships that will be used in years to come. Combining the forecasts, quantities of goods may be translated into numbers of ships of various types, all of which must be accommodated by the marine side of the port operation.

From these forecasts, the *design ship* size will be derived, but the increase in numbers of ships also imposes pressures on the approach channel design as it increases the frequency of ship to ship encounters.

Finally, changes in the nature of cargoes handled (for example, by the introduction of containers or car carriers, and hence ships with high windage) can also affect the design ship selection and hence the channel design and environmental requirements.

1.3.3 Basic Definitions

A more complete set of definitions is given in Appendix B Glossary, Abbreviations and Symbols, but certain fundamental definitions for approach channel, channel and fairway are repeated here for clarity:

Approach Channel

An approach channel is defined as any stretch of waterway linking the berths of a port and the open sea. There are two main types:

- An outer channel in open water and exposed to waves that can produce significant vertical ship motions of heave, pitch, and roll
- An inner channel that lies in relatively sheltered waters and is not subject to wave action of any significance to large ships

The channel normally terminates at its inner end in a manoeuvring area (turning and/or berthing area) which allows stopping, turning and berthing manoeuvres to be undertaken.

Channel and Fairway

The channel is a feature of a waterway that has a width and depth that is sufficient to allow safe passage of the design ships (see Figure 1.1). It might be dredged or may be naturally occurring.

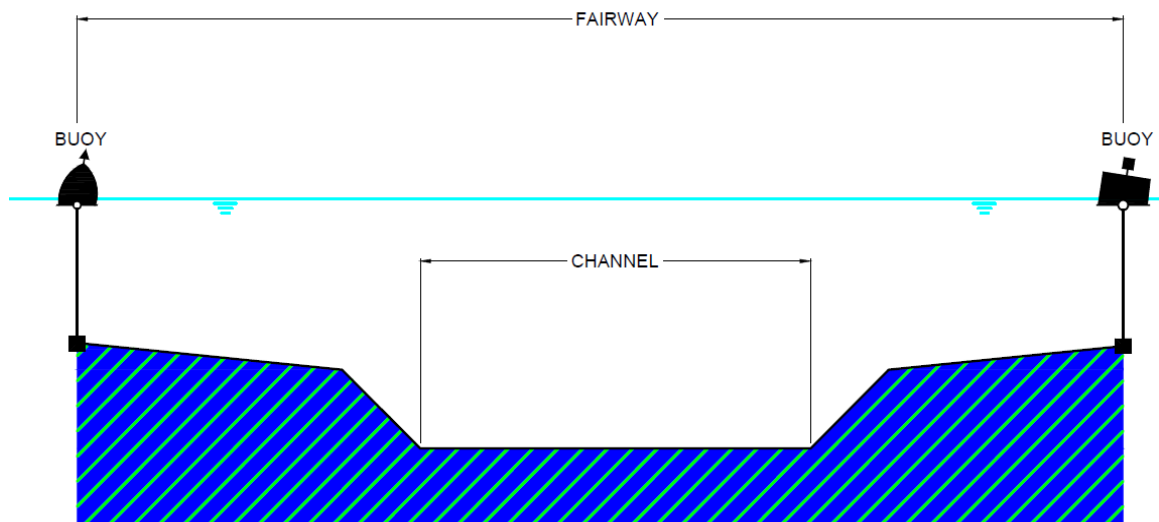

Figure 1.1: Channel and fairway definition

(where the channel is defined by the channel bed width or width at nominal bed level (see Chapter 3))

In some countries the fairway is defined as the wider navigable waterway (for all vessels), and can be marked with buoys to indicate the limits of safe navigation. The fairway markers may be positioned to allow the passage of smaller vessels on either side of the dredged or design ship channel. In some cases, both the deep water channel and the outer lanes for smaller vessels may be marked.

1.3.4 General Project Criteria

1.3.4.1 Basic Criteria

The basic criteria for defining a channel and its related navigation areas are safety of manoeuvres and operations. The government, port authority or terminal owner/operator defines the desired cargo throughput which in turn enables the type and size of the design ship(s) to be identified, along with other conditions. The task of the designer is to convert these basic criteria into a finalised design that is usually the result of several iterations, in agreement with the owner/port authority/engineers. Once safety criteria are set, alternatives may be examined to determine the most suitable solution for the case under consideration, with the understanding that any alternative must respect the previously defined safety factors. Also at this point, it is necessary to assess the criteria for the channel with respect to potential ship size changes and cargo types in the future.

For example, deciding the depth to which a channel is dredged, as a function of local tides and waves, can be based on economic and environmental considerations, but the consequences of the decision should be variations in the time when the channel can be used safely, and not variations in levels of safety. The economic analysis therefore is a trade-off between investment, port availability and efficiency, but not between investment and risk, since recommended safety requirements must always be maintained.

1.3.4.2 Elements Defining a Channel

Design and definition of a channel and its related navigation areas requires determination of the following elements:

- Geometric configuration of the water and above-water spaces from plans and sections that define all dimensions including axes, alignments, curves, heights and levels and datums
- Aids to navigation to identify and mark such spaces
- Maritime and atmospheric limiting conditions which will allow the channel and its related navigation areas to be used under normal operating conditions. These conditions may be different according to vessel type and dimensions, or other defined conditions
- Required pilotage, escorting and towing requirements for certain types of vessels to ensure safe navigation under normal operating conditions

A channel is therefore defined not only by its geometric characteristics but also by its aids to navigation, its limiting operating conditions and by any need to use pilots, tugs or patrol vessels.

1.3.4.3 Types of Ships and Characteristics

Ship Classification

Ships may be broadly classified by their cargoes as high density and heavy ('weight' carriers) or low density ('volume' carriers). The 'weight' class includes cargo ships (general cargo ships, break bulk and dry bulk carriers) and oil tankers (crude oil and chemical product carriers). The 'volume' class includes container ships, RoRo (Roll on/Roll off) ships, Pure Car Carriers (PCC, only cars), LPG (Liquefied Petroleum Gas), CNG (Compressed Natural Gas), LNG (Liquefied Natural Gas), Passenger cruise ships, and Ferries (conventional and single hull, catamaran or hydrofoil fast ferries). Specialised ship types include warships, fishing boats and pleasure craft (power boats and sailboats).

Load Capacity

The most often used parameters for defining a ship according to its size and load capacity are:

- Deadweight Tonnage (DWT) – Maximum load plus fuel, lubricating oil, water, stores, crew and supplies in tonnes (t). This parameter is often used to define 'weight' carriers
- Gross Tonnage (GT) – Although expressed as a 'tonnage', this is actually a complex measure of the overall internal volume of the ship's enclosed spaces according to the IMO's (International Maritime Organisation) 1969 International Convention on Tonnage Measurement of Ships. There are no units associated with GT as it is a non-dimensional quantity. This parameter is often used to define 'volume' carriers.

Specialised parameters are often used to express load capacity for specific ship types. For instance, the TEU (twenty foot equivalent unit) is used to define the capacity of container ships, cargo volume (m^3) for LNG, CNG and LPG gas carriers, Car Units for Car Carriers, lane-metres for RoRo vessels and Pax (number of passengers) for passenger vessels.

Load factors come into play if the ship is less than fully-loaded since this affects its manoeuvrability and response to environmental factors. The ship's displacement or weight displacement (Δ) is equivalent to the weight of water displaced in tonnes. Usually, Δ is listed for the fully-loaded ship. The 'Light Displacement' (LD) description corresponds to the basic weight of the ship as it comes out of the shipyard with no cargo, fuel, or ballast. Typically, LD is the difference between the fully-loaded Δ and the DWT, or approximately 15 % to 25 % of the full-load Δ . The minimum displacement at which a ship can safely sail is known as the 'Light Load' or 'Ballast Displacement' (BD) condition. It is equal to the LD condition plus the minimum ballast to ensure safe navigation in terms of stability and propeller submergence and is typically 20 % to 40 % of full-load Δ , or 30 % to 50 % of DWT.

Ship Dimensions

Principal ship dimensions, as illustrated in Figure 1.2, include the length overall (L_{oa}), length between perpendiculars (L_{pp}), beam (B), and full-load draught (T_{FL}). In addition, because a ship is restricted by the height of bridges or cables over fairways, total height (ship height from keel to top of ship, H_{kt} , or from water surface to top of ship, H_{st}) is also a principal dimension. The principal dimensions and above-water shape (and hence windage) are determined by whether the ship is a 'weight' or 'volume' carrier. The former are characterised by a deep draught and relatively low windage, the latter by a light draught and higher windage. Note that the fresh water draught T_{fw} is greater than the draught in seawater T_{sw} since the density of fresh water, ρ_{fw} is smaller than ρ_{sw} . Some example ship parameters are listed in Table 1-1. Additional details are contained in Appendix C.

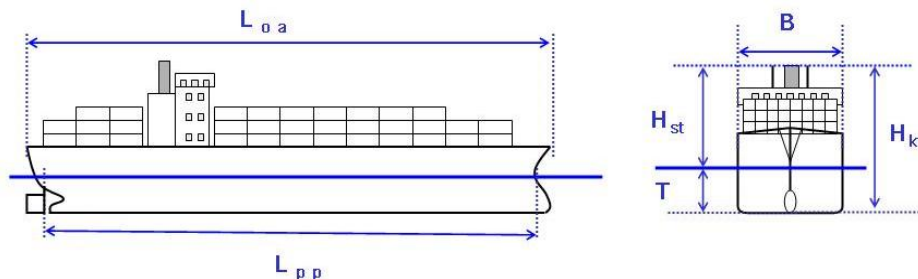

Figure 1.2: Typical ship dimensions

Classification	Displacement (t)	Capacity	Length overall L_{oa} (m)	Beam B (m)	Draught T_{FL} (m)
Tankers					
Panamax	90 000	70 000 DWT	245.0	32.2	12.0
Aframax	140 000	125 000 DWT	274.0	43.8	16.2
New Panamax	220 000	170 000 DWT	366.0	49.0	15.2
Suezmax	238 700	185 000 DWT	330.0	53.0	18.6
Bulk Carriers					
St Lawrence Seaway	35 000	25 000 DWT	226.0	24.0	8.0
Panamax	86 000	70 000 DWT	236.0	32.2	12.0
Capesize	192 000	150 000 DWT	294.0	45.9	17.5
New Panamax	220 000	180 000 DWT	366.0	49.0	15.2
Chinamax	450 000	400 000 DWT	365.0	65.0	22.0
LNG Carriers					
Spherical	107 000	145 000 m ³	283.0	42.7	12.0
QFlex	141 000	218 000 m ³	315.0	50.0	12.0
QMax	175 000	267 000 m ³	345.0	55.0	12.0
Container ships					
Panamax	83 000	5 000 TEU	290.0	32.2	13.2
New Panamax	180 000	13 000 TEU	366.0	49.0	15.2
Suezmax	210 000	15 000 TEU	382.0	56.4	15.5
VLCS	260 000	18 000 TEU	400.0	59.0	18.0
<p>Notes:</p> <ol style="list-style-type: none"> 1. Dimensions in this table are maximum values for each column and may not occur simultaneously for the same vessel. 2. Panamax vessels: Classification of ships for the old Panama Canal locks. Maximum L_{oa} = 289.6 m, except L_{oa} = 294.81 m for passenger and container ships. Maximum B = 32.37 m. Maximum T = 12.04 m in tropical fresh water. 3. Suezmax = Draught and beam combinations limited to sliding scale as a function of wetted cross-sectional area of hull. 4. New Panamax = Classification of ships for the new Panama Canal locks or third set of locks. Maximum T = 15.2 m in tropical fresh water. 5. VLCS = Very Large Container Ships: Container ships larger than New Panamax. An example is the new Maersk Triple E which is of the order of 200 000 DWT and 18 000 TEU. 6. Prior to new Panama Canal locks in 2014, Post Panamax classification referred to ships larger than original locks. This classification will probably become obsolete after the new locks open. 					

Table 1.1: Example ship dimensions and classifications

Specific Waterway Capacity

Ship design is often constrained by the boundary conditions required by the dimensions of important waterways and harbours, such as the Panama Canal and the Suez Canal. Some examples with typical maximum dimensions are listed in Table 1.1. Many of these classifications are based on particular waterways and harbours.

Future Trends

No-one knows for certain how future ship dimensions will develop, but history suggests that they may continue to increase. For example, modern container ships continue to increase in size in all dimensions, especially length and beam. The draught is the last dimension to increase so as not to restrict entry in shallower channels and harbours. Channel boundary conditions imposed by waterway and harbour authorities will still affect future trends. For instance, the dimensions of the new Panama locks have created a new class of vessels, the 'New Panamax'. As a consequence the commonly used term Post-Panamax may change in the future.

Ships are designed to travel as efficiently as possible from port to port, mainly via open sea and their design focuses on carrying the maximum amount of cargo whilst reducing drag and lowering fuel consumption, using streamlined underwater forms that include bulbous bows and stern transoms. However, once they enter shallow, laterally-confined access channels they begin operating in an environment for which they have not been optimally designed. This can give rise to problems in ship handling and higher squat values which can reduce underkeel clearance (UKC) and safety. Channel designers, port authorities and operators need to decide how to manage these trends to remain competitive in the global market while still ensuring safe port operations.

1.3.4.4 Limiting Operational Conditions

Handling a ship in all conditions of tide and weather is not always possible in the confined waters and low speeds associated with port operations. If the UKC is too low, the waves too high, the current too strong, the wind speed too great, the vessel speed too low or the visibility too poor, the ship may be endangered. The pilot may not be able to control the vessel safely, tug operations may be compromised or berthing may not be possible.

There are certain limits beyond which operations become unsafe and it is important that the designer is able to quantify these limits in the design stage. In addition, the designer may need to make allowance for any existing operational limits. If operational limits are particularly restrictive, they may have a significant commercial impact on port operations, and it may be decided to modify the design to allow greater freedom.

Vessel speed limits, both minimum and maximum, are also regarded as operational limits. In some cases tidal and speed limits may interact, for example, where a vessel is passing down a long channel on a falling tide.

Operational limits may also be dependent on ship-based factors, such as the ship type, its manoeuvrability and navigation equipment and systems, which may have a significant impact on the evaluation of limiting conditions when the ship can use the channel safely. Also the type of cargo (especially hazardous cargo) may affect operational limits or procedures.

Different reaches or stretches of a channel may have different limiting operational conditions. Depending on these limiting conditions, different horizontal and vertical dimensions may be obtained for each stretch, with different tug and aids to navigation requirements. This can adversely affect availability and efficiency of the channel.

1.3.4.5 Human Error and Project Uncertainties

Approximately 70 to 80 % of maritime accidents are caused by human error [Hansa 2006, 2010]. The remainder are caused by mechanical breakdowns of ship or tug equipment (i.e. engines and steering gear) and a small percentage by the channel itself (i.e. lack of proper maintenance of channel dimensions). The uncertainties in channel operations can be classified in four different groups (see Chapter 4.1):

- Uncertainty of the risk event
- Uncertainty of the available data
- Statistical uncertainty
- Uncertainty in any operational model being used

Human factors have a special relevance in the design of channels as each vessel manoeuvre is a consequence of human decisions, which are made by the mariner (e.g. ship's master, pilot and/or helmsman) and carried out by other people (tug crews, port/terminal operators). This uncertainty derives from human behaviour and affects the people involved, as well as the risk event itself and the model uncertainty.

Consequently, the design process needs to take into account human factors by using, for example, more sophisticated design tools (such as real-time simulation). Risk analysis, which is recommended, should also take into account human factors.

Operational regulations are an essential part of correct channel design. They should be developed with the active collaboration of the operators and mariners (e.g. pilots) and to cover all types of predictable events with the objective of managing risks within acceptable limits.

1.3.5 Physical Environment Data

1.3.5.1 Data Requirements

It is important to obtain as much information as possible about the environment in which the channel will be placed so its width, depth and alignment may be determined appropriately. In addition, it is necessary to consider changes which may occur to environmental conditions as a result of the proposed design of the channel and any manoeuvring areas and swinging areas (and other associated port structures).

In some cases only sparse information may be available and it is with this that key decisions relating to the channel design may have to be made. In this case, extrapolation of existing knowledge and the use of assumed frequencies of occurrence of environmental effects are required. In general, the designer should err on the side of conservatism, especially when the environmental situation is not fully known and so assumptions need to be made. The original design can therefore be refined, and, possibly, savings made, if the environment is subject to continuous monitoring.

For a channel and navigation area design, physical environment data is required for:

- Wind
- Waves
- Currents and tidal streams
- Tide cycles and elevations

- Seabed bathymetry
- Seabed geotechnics
- Siltation
- Seawater/fresh water effects
- Visibility
- Ice

In many existing ports, sufficient data will already be available for Concept Design, but surveys and preliminary investigations are frequently required.

Since the prediction of winds, waves, tides, currents and visibility depends on long-term statistics, early identification of the need for additional data collection is important.

1.3.5.2 Physical Environment Issues

Weather and sea conditions have major effects on ship manoeuvring. The effects of wind and currents are particularly important for channel width design because ships proceed with a drift angle under the action of wind and current. Particular attention should be paid to the following aspects:

- *Winds*: Wind forces acting on ships vary according to the size and shape of the ship. Wind effects are particularly important for channel design because ships often proceed with a drift angle under the action of wind.
- *Waves*: Waves cause ship motions such as heave, roll and pitch, as well as horizontal drift due to wave forces and passing vessels. Ship motions should be taken into consideration when designing the water depth of the channel.
- *Visibility*: Visibility is a very important aspect for ship handlers when navigating in the channel. Channel traffic is often stopped in poor visibility, but when permitted the aids to navigation need to be sufficient to assist safe navigation.
- *Tide*: The tide affects the depth of water in the channel. Ships can navigate at high or low tide according to depth of water and ship's draught. Tide must also be taken into consideration when high air draught ships pass under bridges and overhead cables.
- *Tidal currents and river flows*: Longitudinal flows or cross-currents significantly affect vessel manoeuvrability and the areas required to safely carry out necessary manoeuvres. Furthermore, current speeds and directions can vary along the length of a channel, especially at curves and channel intersections, and also with time. Special care is required to ensure adequate channel width is provided where ships navigate at slow speed under cross-current.
- *Geotechnical conditions*: Seabed geotechnical conditions affect the required UKC, because the consequences of a vessel touching the seabed are much greater if the seabed is hard. Additionally, the presence of mud in suspension affects vessel manoeuvrability and makes the identification of the seabed difficult.
- *Coastal processes*: Dynamic coastal processes affect and are affected by navigation channels. The development of a new or modified channel can lead to a change of site characteristics. Siltation rates in dredged channels should be considered for maintenance and risks of grounding.
- *Ice*: The presence of ice can significantly affect vessel manoeuvrability or even prevent navigation. Design of channels for navigation in ice is outside the scope of this report, but data on frequency and intensity of ice cover is required wherever this is a possibility.

1.3.5.3 Data Analysis and Modelling

The design methodology presented in this report makes use of a range of data collection methods and design tools available to the designer of approach channels. The data collection methods and analyses are extensively discussed in the PIANC Report 117 [PIANC, 2012]. The methods shown are necessarily based on the current state of technology, techniques and knowledge. However, they are intended to allow and encourage designers to keep up to date with and make use of, future developments, as long as the limitations and underlying assumptions or simplifications of any method or model are recognised.

The design tools available may be classified broadly as:

- Analytical
- Numerical
- Physical

Analytical tools are models which allow for the analysis of wind, waves and currents as well as some of the probabilistic aspects of marine traffic and risk. Examples are the elementary analysis of waves and the frequency distributions used for the arrivals of ships at a port or at a position along a channel.

Analytical models are supplemented (and in some cases superseded) by numerical models based on the use of digital computers. These have revolutionised approach channel design; examples are models of water flow, ship manoeuvring and traffic flow.

Analytical and numerical models can only be as good as the understanding of their physical processes allows. In some instances of port design this knowledge may be sparse and the mathematical models need to be supplemented by physical models, e.g. laboratory models to investigate wave propagation in a port, or ship models passing over complex seabed bathymetry.

All these design tools can and should be supplemented by experience. This includes the personal and corporate experience of the designer and the practical experience of the mariners who use (or, for a new port, will have to use) the results of the designer's efforts. It is essential that this and other relevant experience be sought and brought to bear as early in the design process as possible, with a multi-disciplinary approach being a great advantage.

1.3.6 Elements of Channel Dimensions

1.3.6.1 Channel Depth

Details on the design of channel depth are presented in Chapter 2. To summarise, the water depth necessary in each location should be determined taking the following factors into consideration:

- Vessel draughts and factors (manoeuvrability margins and safety factors) related to vessels which may cause some point of their hulls to reach a level lower than the keel under static or dynamic conditions in seawater

- Water level considered and the factors affecting its variability which will determine the reference plane for the (vertical) position of the vessel, including chart datums, astronomical tides, meteorological surges, variations in river flow rates, etc.
- Seabed and the aspects that affect its variability, including bathymetry inaccuracies, sedimentation and dredging performance tolerances

It should be noted that depths of channels expressed on bathymetric surveys or nautical charts as 'maintained depth' should be guaranteed depths that take into account all factors related to the seabed including siltation. Whereas, sea water depths on nautical charts in the outer approaches to ports only consider the factors related with survey inaccuracies and dredging execution tolerances, without considering possible siltation since the date of the survey.

Due to the wide variety of levels that might be used when deciding the sea water depth of channels, it is recommended that all studies be referenced to Chart Datum. Confusion can easily occur where terrestrial surveys use a reference level such as Mean Sea Level, often at an arbitrary location unrelated to the location of the project.

Particular care to avoid errors is required if either Chart Datum or Lowest Astronomical Tide (LAT) is not at a constant level throughout the length of a channel. It should also be noted that Chart Datum and/or LAT are not necessarily the lowest sea water level, due to the possibility of negative surges.

1.3.6.2 Channel Width

Details on the design of channel width are presented in Chapter 3. In general, there are two channel width classifications: one-way and two-way. One-way channels are sufficient for shorter channel lengths with little or no concurrent two-way traffic. Otherwise, two separate channel lanes to accommodate two-way traffic are required. Where appropriate some longer one-way channels can have passing places, i.e. wider channel sections where (sometimes limited) two-way traffic is permissible.

To summarise, the following factors shall be taken into account to determine the configuration and plan dimensions of channels and related navigation areas:

- Size, dimensions and manoeuvrability characteristics of the vessels and the related vessel aspects, including tug availability and manoeuvring space
- Available aids to navigation and related aspects that affect accuracy and variability of manoeuvring and the definition of channel boundaries and reference points
- Physical and geometrical conditions of the channel and aspects that affect its variability, including uncertainties in its determination, erosion, siltation and sedimentary deposits, tolerances, etc.

1.3.6.3 Links between Vertical and Horizontal Dimensioning

In this report, channel depth and width are discussed independently, but of course, they are interlinked. The strongest link between vertical and horizontal channel dimensions is the ship's speed through the water. Another important link is that for smaller UKC, the response of the vessel to rudder action becomes slower (the vessel becomes more 'sluggish'). Waves in combination with cross-winds, cross-currents and aids to navigation (AtoN) also play a role in the channel design. Whether planning and dimensioning is carried out by means of deterministic or probabilistic methods, the designer must be aware of these links and their consequences in the overall channel design. When using

probabilistic methods (see Section 1.4.3), a joint probability approach can be used to distribute probabilities between vertical and horizontal dimensioning.

1.3.7 Design Verification Procedures

The verification procedure is the system used to check that the channel fulfils all the requirements of the Recommendation. This verification can be carried out using different methods corresponding with one of the procedures described in the following sections.

1.3.7.1 Deterministic Verification

With deterministic verification, the geometric vertical and horizontal dimensions of the channel are calculated by adding several factors which, in most cases, lead to a specific result whether using tabulations or mathematical formulations.

Safety factors in this deterministic procedure are implicitly considered by an assessment of both local environment and ship and operational issues (see Tables 2.2 for depth and 3.4 to 3.8 for width). For channel width, simulator studies (see 3.2.3) or physical model testing is recommended.

1.3.7.2 Probabilistic Verification

With probabilistic verification a statistical analysis of space occupied by vessels for different manoeuvres is used to assign a pre-defined risk in each case for the channel dimensions.

For horizontal plan dimensioning (channel width), the practical application of this method requires use of simulator studies, statistical techniques, scale model testing or real-time measurements to provide a statistical data base sufficiently representative of the method's reliability. For vertical dimensioning (channel depth), these techniques are usually the most appropriate.

In probabilistic verification safety factors are implicitly considered in the analysis as dimensioning is based on not exceeding pre-defined risk probabilities, which are established depending on required levels of safety in each case.

1.3.8 Safety Factors

Safety factors consist of safety coefficients and safety margins. A safety coefficient is usually a multiplier while a safety margin is an additional length or distance. Safety coefficients are used in both deterministic and probabilistic analyses, while safety margins are for deterministic design. Safety coefficients can be based on a frequency of exceedance of a particular variable or for a global probability of failure. The method of analysis and appropriate safety factor is usually based on channel type and use, bottom hardness, ship type and speed, traffic density, overhead obstacles and safety level concerns. Additional details on selection of safety factors are contained in the report.

1.4 Processes in Channel Design and Design Philosophy

1.4.1 Design Process

In this report the design of navigation channels is considered to be a two-stage process consisting of

- Concept Design
- Detailed Design

The methodology is based on the initial premise of a design ship or, in some cases, design ships. The design process is an optimisation task between navigation, safety, economic and environmental factors, with consideration of any other constraints. The overall logic of the channel development process is shown in Figure 1.3.

Variations in the design process may exist depending on the type and scope of the project, although the main phases are still the same. In the case of upgrading and improving an existing channel there are likely to be more constraints because of existing infrastructure, activities and practices. On the other hand, there will also be more information and data about navigation and conditions along the existing channel. In all channel projects, the basic design methodology and the basis and guidelines for dimensioning the channel are, in principal, the same.

1.4.1.1 Concept Design

The Concept Design stage includes preliminary design of channel width, depth and alignment using data and formulae given in design guidelines together with other relevant data relating to ships and environment. The process may include plans from rough estimates to more detailed and accurate plans.

At the very first design stage only rough estimates of the dimensions of the proposed channel (width, depth and alignment) are determined. The process is intended to be rapid in execution and not require excessive input data, so that alternative options (for trade-off studies) can be evaluated rapidly. The output physical parameters will be combined with proposals or assumptions on operational limits and aids to navigation.

This draft design is primarily based on existing data. No specific design tools or methods (such as simulators, etc.) are used in this stage. Comments and feedback from experienced users (pilots, mariners, etc.) can also be important in this planning process, where applicable.

In this phase a large number of alternatives may exist. The alternatives may concern width, depth and alignment, as well as design ships of different types and sizes. Although only approximate dimensioning methods are used and rough cost estimates are made, it should be possible to identify the most unsuitable proposals. This allows the number of alternatives to be minimised during the Concept Design so that only the most practicable solutions will be considered during the subsequent design phases.

The Concept Design may consist of more than the initial phase. After the first estimates and draft designs, more detailed design for alignment, width, depth and channel markings may be required. Dimensioning should be made according to internationally accepted standards and guidelines (e.g. this report). All available data is gathered and used and necessary field studies are conducted. Preliminary simulator (simplified simulation models

that produce tracking charts or more sophisticated large scale simulators) tests and risk analyses can be made. Simulator based studies are valid especially if after the first design phase there are still several possible alternatives regarding dimensions and layout of the channel.

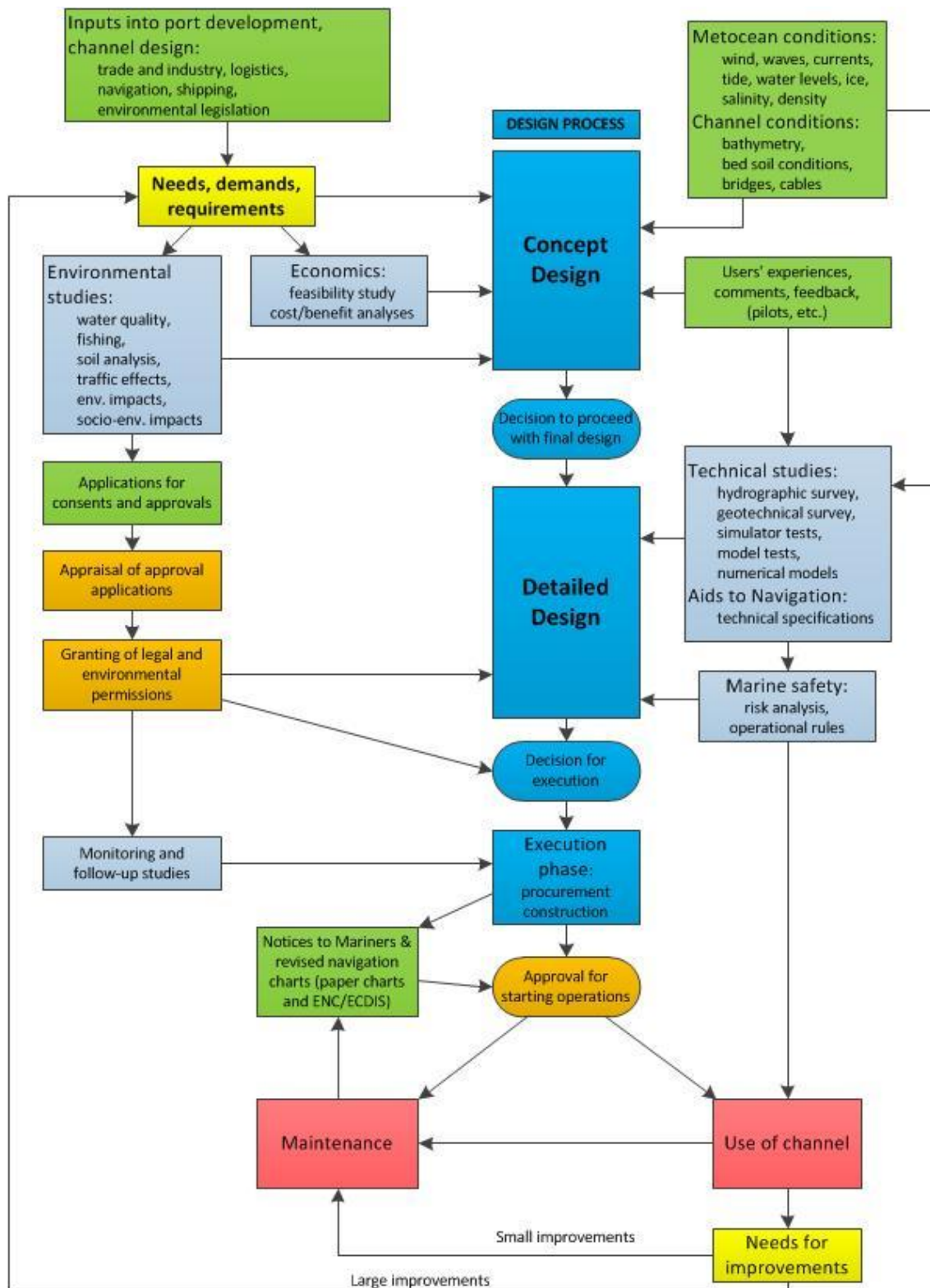

Figure 1.3: Overall channel development process

Channel marking may have a significant impact on the channel alignment and dimensions. For this reason the planning of aids to navigation should form part of the early design stage, interacting with other design aspects. In the concept design stage, a preliminary design of the number, location and type of aids to navigation is prepared. Different marking alternatives may be tested in simulator tests.

The Concept Design stage should lead to a sound and reliable idea of the approximate layout and dimensions of the channel, its safety and navigability, execution and maintenance costs, other impacts and a plan for the further studies needed for Detailed Design.

Based on economic, technical and navigational studies the decision for the final/main alternative for implementation should be made after the preliminary design. Only when particular reasons exist will more than one solution be chosen for detailed design. For environmental impact studies, at least one design alternative is required.

Based on generally used design standards and guidelines, the results of the Concept Design stage are slightly conservative. This is because general guidelines cannot assess all case-specific features and conditions and because further data may be obtained for the detailed design stage. More detailed optimisation and final adjustments must be undertaken at the detailed design stage. Especially when using deterministic design methods, dimensioning is made by combining different factors/components together which may lead to overestimation since all the factors do not necessarily occur at the same time, place and direction.

The output of the Concept Design phase is intended to provide a realistic representation of the project and its costs and to provide a sound basis for the decision whether to continue with the project.

1.4.1.2 Detailed Design

Detailed Design is a more rigorous process intended to validate, develop and refine the Concept Design. The methods used in Detailed Design rely on both numerical and physical models and therefore require more extensive and detailed input, as well as proper judgement and experience in the interpretation of their output.

The outputs of the Detailed Design may be subjected to further checking for acceptability by means of marine traffic analysis, risk analysis and cost/benefit estimates. The results of these checks may lead to adjustments and a further cycle of Detailed Design.

Other aspects of Detailed Design include the number, type and positioning of aids to navigation, consideration of detailed navigational aspects (such as navigation through bridges) or localised channel problems for which the recommended width or alignment requirements cannot be satisfied. Questions referring to winter navigation in northern channels may also have an impact on the Detailed Design.

The operational aspects shall be checked during this phase. Operational rules should refer to weather conditions, ship size and properties, tug assistance, piloting, etc. In many cases simulation based studies are necessary to define operational rules, but numerical and physical model tests are also needed in some cases.

If the conditions considering navigational, technical, environmental and economic aspects are relatively simple and all the design criteria are easily fulfilled, there may be no need to make significant adjustments to the Concept Design. In that case large scale risk

analyses, simulator tests and additional research are not necessarily needed. The main purpose of the Detailed Design process is to determine an optimum design that will definitely be safe and usable without unnecessary expense.

In Chapters 2 and 3 of this report the Detailed Design of channel depth, width and alignment is considered using techniques which represent good present-day practice. As in Concept Design, depth, width and alignment are considered separately, although as discussed in Section 1.3.6.3 they are closely interlinked.

1.4.2 Design Methodology

1.4.2.1 The 'Design Ship' Concept

Approach channels are designed using the concept of a 'design ship'. It should be chosen to ensure that the channel design allows it, and all other ships that are likely to use the channel, to navigate in safety. The channel has to satisfy various criteria and it may well be appropriate to consider more than one design ship in the design process to determine channel width, depth, bend radii and overhead clearance. The obvious initial choice is to select the ship with the largest dimensions, but other criteria may be equally important including manoeuvrability, load factor, windage, hazardous cargo, traffic density and patterns (navigation environment), channel orientation, environmental exposure to waves, wind and currents, frequency of navigation, dredging costs, acceptable downtime, tidal windows and special or infrequent events.

For instance, two-way navigation for smaller vessels, with passing and overtaking manoeuvres, may be more of a controlling factor than one single larger ship during one-way transit. A deep-draught design ship might be used to determine channel depth while a shallower draught ship with a larger beam and windage, and/or poorer manoeuvrability might be used for channel width. Depending on transit times and traffic, it may be possible to use tidal windows to bring in deeper draught ships than would normally be accommodated. Thus, the choice of the design vessel to ensure safe use of the channel should be determined in coordination with the port authority/terminal operator/owner, designer and major port users prior to the actual channel design. As discussed above, there may be several design vessels with each one assigned to address a different aspect of the ultimate channel design.

Moreover, as will be analysed in later chapters, geometric plan or elevation dimensions of channels depend on different vessel parameters (draught, length, beam, windage area, manoeuvrability, etc.) and it will therefore be necessary to consider as design vessels those vessels leading to extreme values of channel dimensions or other characteristics such as operational limits.

In cases where it is possible to designate a specific design ship(s), the actual dimensions of that ship can be used. However, there are many cases in which only the type of ship and the DWT/GT are indicated and in such cases, the principal dimensions of specific ship(s) cannot be defined. In such cases, average ship dimensions from Lloyd's Register or other sources can be used. Appendix C contains average and statistical ship properties from several sources.

Manoeuvring properties of the design ship usually represent a normal standard level for a ship of its type and size. Special properties of the design ship can be taken into account if known. If the ship has a high standard of manoeuvring characteristics and navigation equipment, minimum channel dimensions can be used. For ships with poorer navigation and manoeuvring characteristics, this will require larger channel dimensions and/or

stricter operational rules/lower operational thresholds. The interested reader should refer to sections on manoeuvrability in Chapters 2 and 3 (Sections 2.1.2.8 and 3.1.2.3, respectively).

1.4.2.2 Channel Depth, Width and Alignment

Much of this report is concerned with the geometry of approach channels that includes their depth, width and alignment. Although for convenience, these three aspects are treated separately, they are to some extent interdependent, with linking elements including the speed of the ship, metocean conditions and overall channel cost (see also 1.3.6.3).

1.4.2.3 Aids to Navigation

Considerations of navigational safety play a crucial role in the design process. Although the width, depth and alignment of the channel will be chosen to provide adequate levels of safety, it must not be forgotten that the navigator will only have evidence of the width and alignment from the visual means provided by (see Section 4.6):

- Charts of the area, either printed or ENC/ECDIS
- Aids to Navigation (AtoN)

1.4.3 Probability Aspects in the Design Process

Probabilistic design methods are widely used to determine the optimum dimensions (channel depth and width) of entrance channels and lead to significant savings compared to the deterministic design approach. An important component of the probabilistic design method is related to the specified acceptable risks and the related safety levels for the channel usage.

1.4.3.1 Marine Traffic and Risk Analysis

Marine traffic and risk analysis are required to check and assure safe use of the designed channel. Marine risk embraces the risk to life, damage to the marine environment and the potential commercial loss to a port in the event of an accident.

Overall risk is determined from the frequency (probability) with which a particular type of incident may occur combined with some measure of its consequence. Consequence may be measured as the extent of injury or number of casualties, damage to the environment or potential loss of revenue. Thus, risk is the product of probability multiplied by the consequence.

The reliability of such estimates is knowledge of the frequency with which a particular type of accident may occur. Although maritime accidents may be classified under various headings, there are some (notably collisions) which lend themselves to analysis by means of computer models, where sufficient data is not readily available. One of the most useful of these is the marine traffic simulation model which can represent present and future traffic streams and their likely interaction.

This allows the frequency of vessel-to-vessel encounters to be estimated and this in turn helps in estimating the probable frequency of collision. Once this is known, marine risk may, in principle, be calculated. In practice, such computations are often used for comparative rather than absolute assessments of risk. In this way the benefits (or lack of

benefits) of the channel design in terms of risk may be determined and any necessary design changes may be made.

1.4.3.2 Vertical Channel Dimensions

The depth of port approach channels is determined by a number of components, which are related to the water level, channel bottom and the ship, as well as seamanship and the risk of human error.

The components related to the ship are the ship's (static) draught, squat, trim, heel, wave-induced vertical ship motions and a net UKC. Variations in these values can occur due to variation in water density, ship's speed, rate of turning and computation uncertainties. For approach channels which are exposed to significant wave action, the maximum wave-induced vertical ship motion is the largest probabilistic factor which contributes to the Gross UKC. Chapter 2 provides definitions of these terms.

When defining probability criteria and levels for ship to bed contact, it is advisable to make a distinction between sailing conditions under average and extreme environmental conditions and the likely consequences of bottom contact. The risks are higher for contact with a rocky channel bed than a muddy bed and are also higher for tankers than for general cargo vessels. Furthermore, the designer should select the criteria that are applicable for the type of environmental conditions to be considered (i.e. average or extreme environmental conditions).

The choice of acceptable probability of grounding should be taken by the relevant authorities, considering all associated risks. This is usually related to an acceptable number of groundings during the lifetime of a channel (see Section 2.5 for detail).

The contribution of the various probabilistic factors to the UKC is not through a direct addition of the expected extreme values. The probability of combined occurrence of the extremes, if considered as independent variables, is much lower than that of the individual factors. Therefore, a direct addition would lead to an 'over-designed' channel depth. A more thorough discussion of probabilistic methods for vertical channel design is contained in Chapter 2.

1.4.3.3 Horizontal Channel Dimensions

A deterministic approach can be used to determine the required bed width of approach channels, as part of the Concept Design. This is related to the beam of the design ship, with a number of additional width factors associated with the vessel's manoeuvrability and speed, the prevailing wind, current and wave conditions, the aids to navigation, the surface condition of the channel bed, the water depth and the cargo hazard level. This is a relatively simple and straightforward method.

For the Detailed Design phase it is recommended that ship manoeuvring simulation (numerical models) is carried out to refine the Concept Design width and to quantify the safety and risk level of the final channel width. This can be part of a probabilistic design approach.

The normal probabilistic design method is to use a ship simulator to manoeuvre the design ship through the channel under the same extreme design conditions as in Concept Design. It is recommended at least ten repetitions of each manoeuvre be carried out, to obtain a statistical spread of the swept paths of ships (that is, the envelope of the ships' extreme horizontal positions). At various sections of the channel the spreading of the

extreme positions of the ship during the passages can be computed, from which a standard deviation of the ship's swept path can be calculated. Using a known distribution function (such as the Normal/Gaussian or a Weibull probability distribution), the probability of exceedance can be computed.

As in channel depth design, a similar probabilistic approach can be followed for the channel width design. The width of the channel can be related to the actual ship sizes, the environmental conditions and the probability of exceedance of the channel width. This will lead to the formulation of limiting operational conditions and allow the computation of channel width downtime for the chosen channel width. The channel width can be optimised by computing the cost/benefit consequences of each option. A more thorough discussion of probabilistic methods for horizontal channel design is contained in Chapter 3.

1.4.4 Risk Assessment

Risk assessment and analysis form a logical and systematic procedure focused on the identification of all the events that could generate a dangerous situation related to navigation, manoeuvres, berthing, mooring and unberthing of vessels in channels and associated water areas. A discussion of risk assessment is presented in Chapter 4.

1.4.5 Upgrading Existing Channels

This report can be used when considering the use of existing channels and associated navigational areas to accommodate vessels different from those for which the channels were initially designed. In some cases, physical limitations will constrain the modification of the geometrical characteristics of existing channels, while in other cases detailed design analysis might show that modifications are not required.

Factors to be taken into consideration include the improvement of manoeuvrability of modern vessels, introduction of improvements to buoys and other aids to navigation, changes in operational procedures, use of suitable or more powerful tugs for the new vessel fleet and the ability to test channels in simulators in varying operational conditions. The use of these resources can often allow the safe use of existing channels or navigational areas for vessels larger than those for which they were initially designed.

2 DESIGN OF VERTICAL CHANNEL DIMENSIONS

This chapter contains a discussion of 'vertical' aspects of entrance channel design including channel depth and air draught. The design conditions for a channel should be based on the choice of one or more likely future scenarios, typically during the next 10 to 20 years, as well as actual operational conditions, such as related to acceptable risk and downtime. The safe minimum depth of the channel has to be determined to limit the cost of dredging and environmental impact. This should be undertaken in an iterative process of overall cost optimisation and should involve port and waterways authorities, since the final choice of these factors will be their responsibility and will have operational consequences.

All channel depth and air draught factors need to be quantified carefully in the design of the navigation channel. Traditionally, the best and safe choice of each of the factors was made separately and then added to obtain the required safe channel depth. This is called a deterministic design, but this method can give a conservative design. Although some factors will be constant and have well-defined values, others will be of a stochastic nature and need to be combined in a probabilistic way with a predefined acceptable probability of exceedance. This, in turn, is based on an acceptable risk for navigation in the channel, which is the sum of the cost consequences of exceedance of the available underkeel clearance (UKC) by ships. This may lead to a full, quasi-, or semi-probabilistic design approach for the optimum depth of the channel. The cost of realising and maintaining the channel has to be considered in view of the total project costs. This may lead to a further computational phase of overall cost optimisation.

The first section in this chapter defines the channel depth factors including water level, ship, and bottom factors. The second section describes air draught factors. The design process is a 'two-stage' process for Concept Design (CD) and Detailed Design (DD). The CD is intended to be rapid in execution and not require excessive input data, so alternative options can be rapidly evaluated in a deterministic manner. The DD is more complex, typically involving statistical and probabilistic methods. The third section presents guidance for the CD that can provide relatively conservative estimates of channel depth and air draught. The fourth section provides more detailed guidelines and equations for DD including probabilistic design concepts. Finally, the last section gives additional guidance for incorporating a full probabilistic design. Some of these design methods feature procedures from the Spanish ROM 3.1 (**R**ecomendaciones para **O**bras **M**aritimas, English: Recommendations for Maritime Works), Japanese NILIM (National Institute for Land and Infrastructure Management), U.S. Design of Deep-Draught Navigation Projects and Canadian guidance, etc. These methods were selected since they illustrate the type of procedures that are recommended to perform these types of analyses. Guidance from other countries and sources can be used if the procedures accomplish the same types of analyses. Interested readers should also see Chapter 4 for risk definitions and descriptions. Examples are provided to illustrate the methods. Due to page limitations, many details for these sections are contained in appendices at the end of this report.

2.1 Channel Depth Factors

This section contains basic definitions of the channel depth factors affecting the vertical design of approach or navigation channels. Figure 2.1 shows the required safe depth of a channel is determined by water level, ship and bottom factors. Each of these factors is interrelated with the others and described in the paragraphs below.

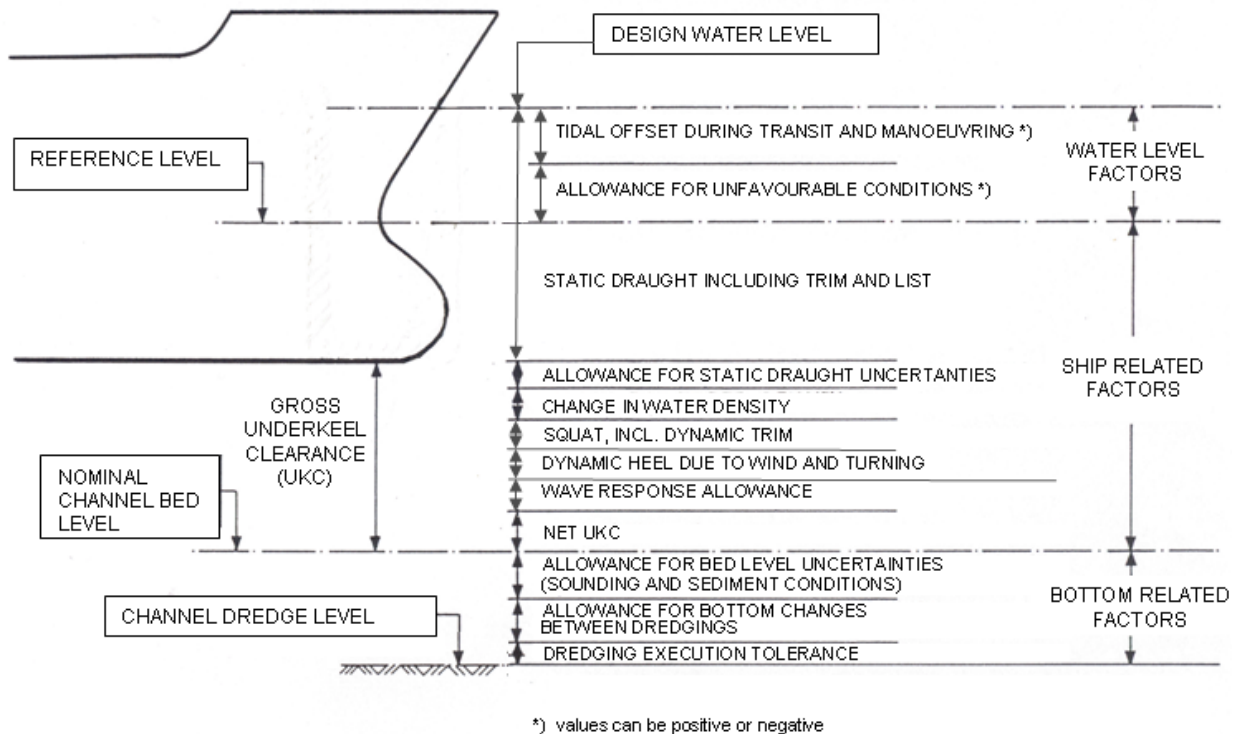

Figure 2.1: Channel depth factors

2.1.1 Water Level Factors

Water level factors include the reference level or datum of the selected design water level and tidal and meteorological effects on this water level.

2.1.1.1 Reference Level (Datum)

All channel depth factors should be related to the same datum level. Although in most cases this is Chart Datum, in some ports different datums are used. For example, for tide recordings this could be the Navy Chart Datum, while bathymetric surveys could be given relative to Port Chart Datum or even Mean Sea Level (MSL). Many countries use LAT (Lowest Astronomical Tide) as their standard reference level for nautical charts. It is very important that such differences in datums are explicitly defined and incorporated in the calculations. It should be noted that the absolute level of Chart Datum can vary across even quite small distances and different values may exist on a single nautical chart.

2.1.1.2 Design Water Level

The design water level is the starting point for designing the appropriate channel depth. It depends not only on astronomical and meteorological effects, but also on the draught of the design ship(s), local operational and economic conditions, ecological requirements and currents. Therefore, determining the optimal channel depth is an iterative process involving trial selection of different design water levels.

2.1.1.3 Tidal and Meteorological Effects

The water level is influenced by astronomical tides and meteorological effects (also by river flow in certain cases and long-term climate change effects). Tides vary in time and space. They can be derived by collection, analysis and interpretation of water level records or can be predicted by tide tables or mathematical models. Meteorological effects are due to winds and moving systems of atmospheric pressure variation and may lead to significant water level increases or decreases in the water level of several metres (e.g. Southern North Sea). For example, in the case of a local atmospheric high-pressure field, an approximate rule of thumb is that the water level will be about 1 cm lower for every 1 mbar increase in pressure above the average (1.013 bars), although winds and moving weather systems can amplify such changes.

In the case of appreciable tidal elevations or long tidally influenced channels, a decision may be made whether to use the channel throughout the tidal cycle. For a harbour accessed by many vessels with different draughts, it may be more favourable to use suitable 'tidal windows'. The size of the tidal window for maximum ship draughts and the draught for tide-independent ships has to be determined based on the dredging costs and environmental impact. High-tide windows can be used to allow deep-draught vessels to sail in the channel with the tide.

Inbound ships may transit the channel on a rising tide, as shown on the left side in Figure 2.2, so that the ship starts at sea some time before high water and reaches the port at high water. More attention must be paid to the design in the case of outbound ships with maximum draught transiting a long tidal channel. They may have to sail against the tide, as shown on the right side in Figure 2.2. In this case they will experience different water levels during the outbound transit. For example, the ship starts on a rising tide at the harbour, passes high tide halfway during the transit, and reaches the sea at low tide. Depending on whether a particular area is passed at low or high tide, the design can be adapted by a stepped depth profile of the channel. For some hub ports, the operational accessibility at very low water reference levels is of prime economic importance.

Ship speed plays an important part in the design process since it interacts with tidal limits. The speed must not be too slow that it adversely affects manoeuvrability or too fast that ship squat and riverbank problems (wave reflection and erosion) are increased. One should note that speed over ground is important for tidal windows, while speed through water is important for manoeuvrability, squat and other hydrodynamic-related factors.

In some ports, currents may be too strong at certain stages of the tide to allow some ships to navigate with safety. This may cause their arrivals and sailings to be restricted to certain time periods (or 'current windows') in the tidal cycle. This implies downtime during which the channel will not be available for such ships and decisions regarding acceptable downtime should be based mainly on safety and secondarily on economic considerations.

Another concern relates to large seasonal fluctuations in water flow in channels and rivers that are subject to wet/dry seasons (e.g. Panama Canal). Finally, discussions on the effect of sea level rise due to global warming are not included, but of course, this could affect both UKC and air draught clearance in the next decades. Designers should be aware of the potential effect of sea level rise and possible increases in storm intensity and check with IPCC (2011) and other agencies (PIANC EnviCom Task Group 3: 'Climate Change and Navigation') on predicted long-term conditions.

2.1.2 Ship-Related Factors

Ship factors include static draught of the ship and the Gross underkeel clearance (UKC). The Gross UKC is composed of six factors including (a) allowance for static draught uncertainties, (b) change in water density, (c) ship squat and dynamic trim, (d) dynamic heel, (e) wave response allowance and (f) Net UKC. Separately, a manoeuvrability margin is checked such that a minimum clearance under the ship (between the seabed level and the lowest average position of the ship) is provided, as discussed in Section 2.1.2.8 of this report.

Wave conditions usually decrease inland from the coast, especially in the shelter of breakwaters. Ship speeds also usually decrease closer to the ship's berth, with a resulting decrease in squat. The channel depth usually becomes shallower as sections are dredged in step-like intervals or transitions. This means the maximum required depth of each channel section is defined at the most seaward end of the section where the conditions are most severe. In the case of a turning area that is exposed to wave action, the vessel will be exposed to beam waves, with resulting relatively large roll motions. Heeling due to wind and turning may add to the required safe depth. A safe minimum ship speed may be required to counteract possible cross-currents if outside a breakwater. Such conditions should be evaluated separately.

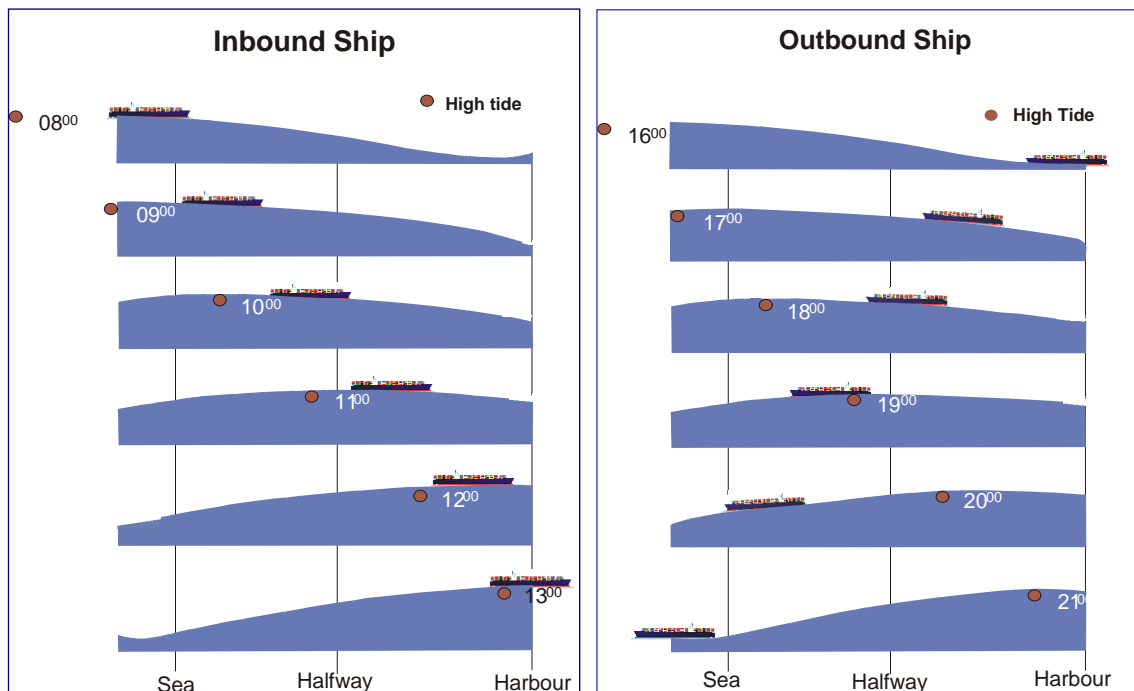

Figure 2.2: Example of inbound and outbound ship passage using the tide

2.1.2.1 Static Draught

The first ship factor is the static draught of the 'design vessel' in seawater (see Section 1.3.4.3). The maximum draught can vary during the passage of the vessel (i.e. fuel and stores consumption, ballast adjustments, etc.). If the ship does not have an even-keel draught, the maximum draught at the bow or stern should be used.

2.1.2.2 Allowance for Static Draught Uncertainties

The first of the Gross UKC components is the *Allowance for Static Draught Uncertainties*. The ship's draught is not always known with absolute certainty. It is usually measured with limited accuracy at the port of departure, where water densities can be different from those at the port of arrival, or where wave conditions around the draught markings on the ship's hull make accurate reading difficult. Another cause of uncertainty could be the static inclination to one side caused by an unbalanced load or ship damage (i.e. list). Therefore, a safe allowance should be made for draught uncertainties.

2.1.2.3 Change in Water Density

The second component of Gross UKC is the *Change in Water Density*. Differences in water density between seawater and fresh water will lead to differences in draught. If a ship moves into water of lower density, the draught will increase almost proportionally depending also on the verticality of the hull at the waterline (i.e. the gradient of the waterplane area). A ship's draught will increase approximately 2 to 3 % in fresh water compared to seawater since ship displacement is inversely proportional to water density (see Appendix C, Eq. C-2).

2.1.2.4 Ship Squat

Definition and Significance

The third and more significant factor comprising the Gross UKC is *Ship Squat* including dynamic trim. Squat is a steady downward displacement consisting of a translation and rotation due to the flow of water past the moving hull. This water motion induces a relative velocity between the ship and the surrounding water that causes a water level depression in which the ship sinks. Shallow water and channel banks significantly increase these effects. The velocity field produces a hydrodynamic pressure change along the ship that is similar to the Bernoulli effect since kinetic and potential energy must be in balance [Newman, 1977]. This phenomenon produces a downward vertical force (causing sinkage, positive downward displacement) and a moment about the transverse axis (causing trim) that can result in different values at the bow and stern (Figure 2.3). Thus, squat is composed of this overall decrease in UKC due to sinkage and change in trim.

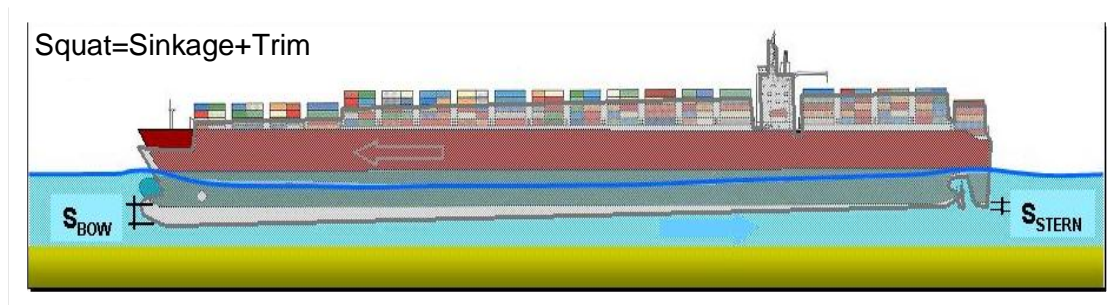

Figure 2.3: Ship squat definitions for squat at the bow [BAW, 2008]

Historically, maximum squat occurred at the bow S_b , especially for full-form ships, such as tankers. In very narrow channels or canals and for high-speed (fine-form) ships, such as passenger liners and container ships, maximum squat sometimes occurred at the stern S_s . Barrass had proposed that the location of maximum ship squat at the bow or stern was mainly due to the block coefficient C_B . He stated that a ship with $C_B < 0.7$ that is typical of container ships would squat by the stern and a ship with $C_B > 0.7$ typical of bulkers and tankers would squat by the bow. Although this threshold value may not be accurate for all ship types, it is still a good reasonable 'rule of thumb'. An equivalent 'rule of thumb' on the location of the maximum squat is given by Römisch since a ship will squat by the bow if $C_B > 0.1 L_{pp}/B$. Appendix C contains listings of C_B in Tables C-1 and C-3.

The initial or static trim of the ship may influence the location of the maximum squat. According to Barrass (1995) for ships with large initial trim, the ship will always experience maximum squat in the same direction as this static trim. Barrass had also stated that the dynamic trim would not change from the initial trim (i.e. if trimmed by the bow, dynamic trim would also be by the bow, etc.). However, recent German research [Härting et al. 2009 ; Reinking et al., 2009] indicates that dynamic trim is a function of mean draught and initial or static trim. This conclusion is based on extensive field measurements of Post-Panamax container ships and bulkers on the River Weser and River Elbe in Germany. The German research also noted a ship could start with a static trim to the bow or stern and end up with opposite dynamic trim, implying that one could potentially optimise the initial static trim to minimise required UKC. Most of the German measurements were for ships with newer transom sterns that are wider than previous generation ships so this increased buoyancy as the ship trims to the stern could be affecting the ultimate dynamic trim back to the bow. The German research is ongoing.

Ship squat has always existed, but was less of a concern with smaller vessels, slower speeds and relatively deeper channels. Nowadays, ships sail with smaller UKC and higher service speeds, so they have potentially larger squat. Given the increasing costs of dredging and maintenance for larger waterway and harbour projects, better prediction of squat can reduce operation and maintenance costs. The consequences of poor squat estimation may include groundings, repair costs, insurance claims, lost bookings and service, and even loss of life.

Factors Influencing Squat

Prediction of ship squat depends on ship characteristics and channel configurations. The main ship parameters include ship draught T , hull shape as usually represented by the block coefficient C_B , and ship speed V_s . Perhaps the most important ship parameter is its speed V_s . This is the relative speed of the ship in the water, so fluvial and tidal currents must be included. In general, squat varies as the square (or even higher) of the speed. Therefore, doubling the speed quadruples the squat and vice versa.

Other secondary ship parameters include length between forward and aft perpendiculars L_{pp} and beam B . The presence of a bulbous bow and stern-transom are two other characteristics of a ship that affect squat. Since these ship features are at the extreme ends of the ship, they naturally affect the ship's trim and squat. Many of the early squat measurements were developed for ships that did not have bulbous bows. Newer designs of bulbous bows, although mainly to reduce drag and increase fuel efficiency, also have an effect on squat. The newer 'stern-transoms' on some ships are 'blockier' (i.e. wider and less streamlined) than earlier ship designs and affect squat as they become more submerged with increases in draught [Uliczka and Kondziella, 2006].

The main channel factors influencing ship squat are proximity of the channel sides and bottom as represented by the channel depth h and cross-sectional configuration. If the ship is not in relatively shallow water with a small UKC, the effect of squat is usually negligible. Ratios of water depth to ship draught h/T greater than 1.5 (i.e. relatively deep water) are usually considered safe from the influences of squat. The ship will still squat in deeper water, but squat is less and there is little risk of touching bottom.

The main types of 'idealised' channel configuration are open or unrestricted channel, restricted or confined channel and canal (Figure 2.4). Unrestricted channels ('U') are in relatively larger bodies of water and usually toward the offshore end of channels. Analytically, they are easier to describe and were some of the first types studied. Sections of rivers may even be classified as unrestricted channels if they are wide enough (i.e. typically greater than eight times the ship's beam). The second type of channel is the restricted channel with an underwater trench that is typical of dredged channels. The restricted channel ('R') is a cross between the canal and unrestricted channel type. The trench acts as a canal by containing and influencing the flow around the ship and the wide overbank allows the flow to act as if the ship is in an unrestricted channel. The last type of channel is the canal ('C'), which is really a special case of the restricted channel with a trench height that extends above the water's surface. Canals are rare for maritime

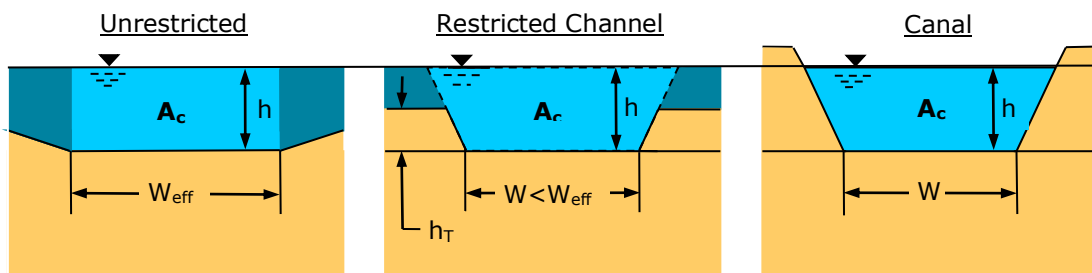

Figure 2.4: Idealised channel cross-sections

shipping and usually used to provide inland access between larger water bodies. Typical examples are the Suez, Panama, Kiel and Terneuzen-Ghent Canals. The sides of R and C channels are usually idealised as one slope when in reality they may have compound slopes with revetment to protect against ship wakes and erosion. The interested reader should see Appendix D for additional discussion.

Many channels can be characterised by more than one of these channel types as the different segments or reaches of the channel have different cross sections. Finally, many real world channels look like combinations of these three types as one side may look like an open unrestricted channel and the other side like a restricted channel with sidewalls. In fact, one could probably entertain the notion of just one channel type: restricted channel. An unrestricted channel can be formed from a restricted channel if the width is large enough and/or side slopes gentle enough. Most of the PIANC empirical formulas are based on ships in the centre of symmetrical channels, so the user has to use 'engineering judgment' when selecting the most appropriate formulas.

The depth Froude Number F_{nh} is a combination of ship and channel parameters and is the most important dimensionless parameter. It is a measure of the ship's resistance to motion in shallow water and is a function of ship speed V_s and water depth h . It is defined as

$$F_{nh} = \frac{V_s}{\sqrt{gh}} \quad (2-1)$$

When F_{nh} approaches unity, an effective speed barrier is reached since the resistance to motion increases so that displacement ships do not have sufficient power to go faster. Usually, ships are restricted to $F_{nh} < 0.6$ for tankers and $F_{nh} < 0.7$ for container ships. These F_{nh} limits should be checked in the design process when selecting design speeds and depths. In restricted channels and canals, this speed barrier occurs at F_{nh} values that are significantly smaller than one. Eloot et al (2008) have proposed a modified Froude Number that includes the effects of lateral boundaries for restricted and canal configurations that takes account of the effect of blockage S and ship geometry (see Appendix D).

Most research on ship squat only considers ships in a steady state condition where the ship speed is assumed constant (i.e. steady state, no acceleration) and the channel is assumed straight without any abrupt changes in configuration or bathymetry. However, changes in squat occur for a ship in a transient state. For instance, squat changes when a ship crosses an abrupt channel depth transition from deep to shallow water or when it is accelerating or decelerating. Ripples on the bottom can also affect ship squat if the ship is in relatively shallow water. Channel bends and proximity to banks tend to increase squat and muddy bottoms may decrease it. The presence of another ship (passing, overtaking, or moored) can affect the squat as ships have experienced a larger squat when passing, overtaking, or being overtaken by another vessel. Additional details on factors influencing ship squat are contained in Appendix D.

Empirical Squat Formulas

In 1997, the PIANC WG 30 report included eleven empirical formulas and one graphical method from nine authors for the prediction of ship squat. They were based on physical model experiments and field measurements for different ships, channels and loading characteristics. The full list of references can be found in Appendix D. Briggs (2006) developed a FORTRAN computer program as part of a deep-draught navigation toolbox (executable version available on request from Dr. Briggs) to predict ship squat for the eleven PIANC WG 30 empirical formulas as a function of ship dimensions, speed and channel configuration. Statistics were presented for average, minimum and maximum values of squat at the bow and stern. Briggs et al. (2010) presented comparisons of concept and detailed PIANC formulas for several example ships and for measured squat from four ships in the Panama Canal (2013). Finally, Briggs (2011) conducted a sensitivity study on the effect of small input changes on the predicted squat for the PIANC empirical formulas for a Post-Panamax container ship.

In this report, seven empirical formulas for squat are included. Table 2.1 lists the empirical formulas and the channel types that are appropriate for each. All will give predictions of maximum squat S_{Max} , usually assumed at the bow. Only the Barrass and Römisch explicitly give predictions of stern squat S_s . Therefore, a key concern is whether it is appropriate to use a formula that was originally developed for bow squat if the ship is a 'slimmer' container ship that will squat by the stern rather than the bow.

Squat Formula	Configuration		
	U = Unrestricted	R = Restricted	C = Canal
Tuck (1966)	YES	YES	YES
Huuska/Guliev (1976)	YES	YES	YES
ICORELS (1980)	YES	(YES)	NO
Barrass3 (2002)	YES	YES	YES
Eryuzlu2 (1994)	YES	YES	NO
Römisch (1989)	YES	YES	YES
Yoshimura (1986)	YES	YES	YES
Notes:			
1. Only Barrass3 and Römisch predict both bow and stern squat S_s			
2. Others give maximum squat, usually assumed at the bow			
3. ICORELS sometimes used for Restricted although originally intended for Unrestricted only. See Appendix D.4.3 for additional discussion.			

Table 2.1: PIANC empirical squat prediction formulas and channel configurations

In addition, each formula has certain constraints that it should satisfy before being applied, usually based on the ship and channel conditions for which it was developed. Caution should be exercised if these empirical formulas are used for conditions other than those for which they were intended. The user should always be mindful of the original constraints. In some cases, this relaxation may be insignificant. For instance, if the ship dimensions or speed slightly exceeds the original constraints, it is probably justified to use the formula. However, some constraints such as the channel type and cross-section should probably be respected. These formulas, associated constraints, and examples, are discussed in detail in Appendix D.

2.1.2.5 Dynamic Heel

The fourth factor of Gross UKC is dynamic heel. During turning of a vessel, heeling will occur depending on the ship's speed, rate of turn, metacentric height and tugboat line forces. The difference between roll and heel is that roll is due to wave-induced oscillations while heel is due to non-oscillating motions from wind and currents. Dynamic heel can also occur when a beam wind and other horizontal or vertical asymmetrical forces on the vessel cause heeling of the vessel. Dynamic heel adds to the ship's draught and depends heavily on beam and windage. Obviously, ships with larger windage are more susceptible to wind-induced dynamic heel.

2.1.2.6 Wave Response Allowance

The fifth component of Gross UKC is the wave response allowance. It is potentially the largest ship factor, especially if the ship is in an exposed channel where large waves are present.

Six Degrees of Freedom Ship Motions

Figure 2.5 illustrates the six degrees of freedom (6DOF) ship motions. There are three translational motions (surge, sway and heave) and three rotational motions (roll, pitch and yaw). Surge (translation along longitudinal X-axis), sway (translation along transverse Y-axis) and yaw (rotation about vertical Z-axis) affect the horizontal design of the channel and its width. Heave (translation along vertical Z-axis), roll (rotation about longitudinal X-axis) and pitch (rotation about transverse Y-axis) affect the vertical design of the channel and are the primary concerns in this chapter. In heave, the ship tends to follow the wave motions up and down. For roll, waves at an angle to the ship's longitudinal axis (especially beam seas) create an exciting moment that is counteracted by a restoring

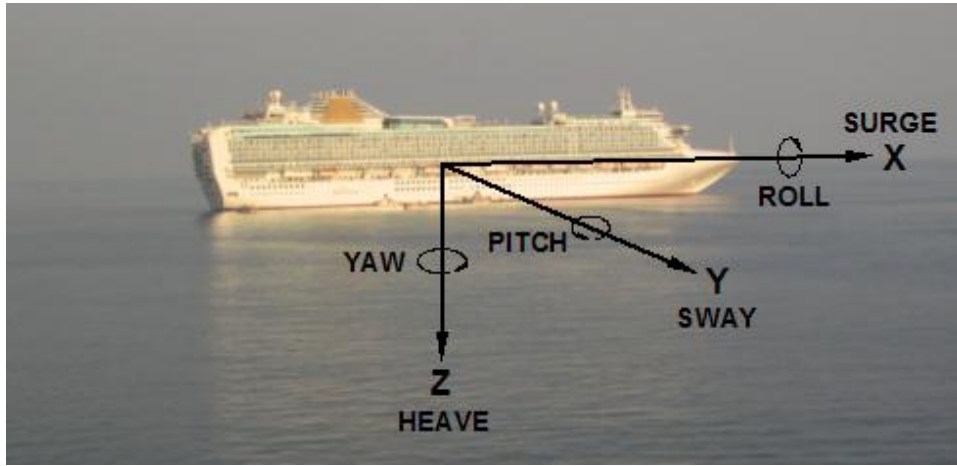

Figure 2.5: Six degrees of freedom ship motions

moment based on the metacentric height. Pitch is a function of the ship length and speed and is most important for head and following seas. When the wavelength λ is approximately equal to the length of the ship L_{pp} or L_{oa} , large wave exciting moments are generated due to a pressure distribution occurring along the hull corresponding to the waveform.

Ship Natural Periods of Oscillation

Ships in water have a natural period of oscillation in heave, roll and pitch. Resonance, with amplification of ship motions, can be expected if their natural period is close to the period of the dominant wave forcing. Hydrodynamic damping limits the extreme amplitudes of heave and pitch, whereas viscous damping limits the extreme amplitudes of roll (for which potential damping is relatively unimportant). Heave and pitch are very dependent on wave motions, especially for following and head seas. Roll is more important for beam and quartering seas.

The ship's natural period in heave T_H (s) is given by:

$$T_H = 2\pi \sqrt{\frac{m_v}{k}} \quad (2-2)$$

where:

- m_v = virtual mass of the vessel (kg) = $m_s + m_a$
- m_s = actual ship mass or displaced mass (kg)
- m_a = "added" ship mass or inertia (kg)
- k = hydrostatic stiffness = $\rho_w g A_{WP}$ (N/m)
- ρ_w = density of water (kg/m^3)
- g = acceleration due to gravity (m/s^2)
- A_{WP} = waterplane area of the vessel (m^2).

For the case of heave motion of large fully-loaded bulk carriers, Eq. 2-2 for T_H can be approximated by:

$$T_H = 10 \sqrt{\frac{T}{g}} \quad (2-3)$$

where T = the ship's draught (m).

For different water depths, heave resonance occurs at different wavelengths. The vertical motion resonance of larger vessels is usually in the range of swell wave periods (i.e. > 10 s). Therefore, under swell conditions, heave resonance can be expected.

For roll and pitch rotational motions, the mass in Eq. 2-2 is replaced by the rotational inertia ($\text{kg}\cdot\text{m}^2$) and the stiffness by a stiffness moment ($\text{N}\cdot\text{m}$). In Japan the natural roll period T_ϕ (s) is estimated as:

$$T_\phi = \frac{2.5B}{\sqrt{g(\overline{GM})}} \quad (2-4)$$

where \overline{GM} = transverse (i.e. y-axis) metacentric height of the ship (m).

The accuracy of the T_ϕ estimate depends solely on the \overline{GM} estimate for the design ship. In general, the magnitude of \overline{GM} depends on the type of ship and varies according to the loading condition. Appendix Table C-3 lists a range of \overline{GM} for different ship types as a function of the maximum design draught for each ship [Tsugane, 2009]. As a crosscheck, Japanese researchers also recommend this simplified formula for \overline{GM} :

$$\overline{GM} = C_1 \left(\frac{B}{25} \right) \quad (2-5)$$

where the constant C_1 is in the range of 0.5 to 2.0, depending on ship condition. A value of $C_1 = 1.0$ gives a good mean value of \overline{GM} .

The pitch natural period T_θ is similarly defined after some simplifying assumptions as:

$$T_\theta = \frac{2.0L_{pp}}{\sqrt{g(\overline{GM}_L)}} \quad (2-6)$$

where \overline{GM}_L is the longitudinal (i.e. x-axis) metacentric height.

Encounter Period or Frequency

To compute ship motion response to a wave spectrum, wave periods or frequencies must be converted or modified to the encounter period or frequency. An associated modification of the wave spectral density is also required to maintain the correct wave energy of the spectrum so that no wave energy is lost due to this Doppler shift conversion. In the case of strong currents, wave-current interaction effects also need to be taken into consideration. If the encounter wave period coincides with or is close to the natural periods of heave, roll and/or pitch of the ship, relatively large vertical motions can occur. Encounter wave periods T_E (s) are computed as:

$$T_E = \frac{1}{f_E} = \frac{2\pi}{\omega_E} = \frac{T_z}{(1 - s_{\text{eff}})} \quad (2-7)$$

where:

- f_E = encounter frequency (Hz)
- ω_E = encounter circular frequency (rad/s)
- T_z = zero-crossing wave period (s)
- s_{eff} = effective speed ratio = $v_x \cos(\psi) / c$
- v_x = ship speed over ground, ignoring any currents (m/s)

ψ = angle between ship speed vector and wave propagation (deg)
 c = wave celerity (m/s)

2.1.2.7 Net UKC (UKC_{Net})

The sixth and last component of the Gross UKC is the net underkeel clearance UKC_{Net} (Figure 2.1). The UKC_{Net} is primarily intended for the deterministic Concept Design (CD) stage of design. ICORELS (1980) defined UKC_{Net} as the minimum margin remaining between the keel of the vessel and the nominal channel bed level, the vessel moving at planned speed under the influence of the most severe winds and wave conditions designed for operational limit conditions. Thus, the required UKC_{Net} is what is left as a 'safety' margin for the ship after subtracting the other ship factors (wave-induced vertical ship motions, ship squat and dynamic heel) from the nominal channel bed level or depth.

ICORELS (1980) noted that UKC_{Net} should be based on kind and size of ship, commodities transported, environmental consequences, density of traffic, etc. They recommended a value of UKC_{Net} at least 0.5 m, but could be increased to 1.0 m where the consequences of touching the bottom is large (e.g. for channels with rocky bottoms).

2.1.2.8 Manoeuvrability Margin (MM)

The term 'Manoeuvrability Margin' (MM) is used to define the time-averaged clearance under the ship. It is a deterministic summation of UKC factors such as water depth, draught, squat and heel intended to set a minimum Gross UKC requirement to provide adequate manoeuvrability for a moving vessel. Ship manoeuvrability may be defined as the vessel's ability to perform the manoeuvres intended by the pilot/master without the assistance of tugs. The ability of a vessel to manoeuvre at its design speed will decrease when the clearance between the channel bottom and the ship's keel is reduced and may become insufficient if it is less than a certain critical value that maintains sufficient flow under and around the ship. PIANC (1985) introduced the MM to define this critical value as the necessary margin between channel bed level and the lowest average position of the bottom of the ship.

The time-averaged clearance between ship and channel bottom should therefore always exceed a minimum value to ensure adequate manoeuvrability. This vertical MM component will also affect horizontal motions leading to increased horizontal risks, as a vessel with a very small MM becomes very sluggish in manoeuvring and therefore has increased risks of collisions or path width excursions.

The effect of wave-induced ship oscillations in heave, pitch and roll are not generally considered to have a significant effect on manoeuvrability. Therefore, only motions which affect the lowest average position of the bottom of the ship need be taken into consideration in the calculation of MM (= depth – draught – squat – heel). For this reason, it is an independent check which should always apply in channel design (and operation), irrespective of whether in the CD or DD stage, or whether using deterministic, semi-probabilistic, or probabilistic approaches.

The limiting value of MM depends on ship type, channel dimensions and alignment, and ship traffic (including whether one-way or two-way). A minimum value of 5 % of draught or 0.6 m, whichever is greater, has been found to provide adequate MM for most ship sizes, types and channels. Applying this guideline to the Port of Rotterdam, for example, gives a minimum required MM of 1.0 m for a 20 m draught vessel, in accordance with current practice at the port. It should be noted that this check of MM is separate from calculations of Gross UKC that includes the wave response allowance.

In practice, MM calculations will control UKC requirements in inner harbour basins and in low swell conditions at outer harbour sections. It should also be noted that tug assistance would allow MM requirements to be reduced in inner harbour areas, where wave action is very limited or absent. An MM value of 0.5 m is commonly used for such tug-assisted operations, irrespective of draught.

2.1.3 Bottom-Related Factors

The channel bed itself has to be at a safe distance below the deepest point of the vessel. It is defined as the nominal, proclaimed, or advertised channel bed level or depth. The actual depth of the channel should always be at least this proclaimed value. The last group of factors in the design of the channel depth are the bottom factors that include (a) allowance for bed level uncertainties, (b) allowance for bottom changes between dredging and (c) dredging execution tolerance. In addition, special considerations apply in the case of muddy channel beds and these are described below.

2.1.3.1 Allowance for Bed Level Uncertainties

The allowance for bed level uncertainties is the uncertainty in the actual depth of the bottom due to tolerances in the measured bathymetric survey data. All sensors have a built-in tolerance or uncertainty that must be considered in the accepted nominal channel bed level or depth.

2.1.3.2 Allowance for Bottom Changes between Dredging

The allowance for bottom changes between dredging has to do with possible sedimentation or siltation that could occur between dredging. This allowance is sometimes known as the 'Advance Maintenance' allowance. The dredged depth is purposely dredged deeper than the required nominal depth to give a cushion for anticipated sedimentation and increase the time before the next dredging cycle will be required. A similar allowance is needed for siltation of natural channels that are not normally dredged.

2.1.3.3 Dredging Execution Tolerance

The dredging execution tolerance is an over-dredging tolerance to ensure the nominal depth is achieved. The dredged bottom is not perfectly flat after dredging, so this over-dredge depth is often included to ensure the nominal depth is achieved.

2.1.3.4 Muddy Channel Beds

Many navigational channels have bottoms that are covered with fluid mud suspensions. Compared with water, such a 'black water' layer is characterised by a density that is somewhat higher (1050-1300 kg/m³), but has comparable rheological properties. Therefore, contact between the ship's keel and the upper part of the fluid mud layer will most likely not damage the ship. If the water-mud interface is accepted as the bottom level, a reduction of the required UKC value could be allowed. Even navigation with a negative UKC relative to the interface can be considered, which implies that the ship's keel is permanently in contact with the mud.

The selection of the water-mud interface as the reference bottom level could be questioned. Indeed, in muddy conditions, the bottom is not clearly defined. Common

depth survey techniques, such as echo sounding, lead to interpretation problems in muddy areas: high frequency signals reflect on the water-mud interface, while low frequency waves penetrate into the sediment deposit and indicate a deeper water depth than actually present. Selecting the upper boundary for the bottom may be on the safe side, but may cause problems for waterway maintenance since the water-mud interface level can show significant tidal and seasonal variations and is difficult to maintain by common dredging methods. On the other hand, navigation safety requires that the master or pilot must always be able to compensate for the effects of mud on ship behaviour by means of control systems or external assistance (e.g. tugs). An acceptable compromise between navigation safety and the cost of channel maintenance can only be achieved using non-conventional definitions and survey methods and requires additional knowledge about the navigational response of ships in muddy areas.

Nautical Bottom Approach

A first step in such an alternative approach consists of replacing terms as *bottom* and *depth* by more appropriate concepts as *nautical bottom* and *nautical depth*. Indeed, within the zone between the water-mud interface and the 'hard' bottom, physical properties of the mud (density, rheological characteristics) change gradually with increasing depth, so a definition of bottom should be based on the local circumstances and the intended application.

The PIANC MarCom Working Group 30 Report defined the *nautical bottom* as "the level where physical characteristics of the bottom reach a critical limit beyond which contact with a ship's keel causes either damage or unacceptable effects on controllability and manoeuvrability." Accordingly, the *nautical depth* was defined as "the instantaneous and local vertical distance between the nautical bottom and the undisturbed free water surface". Intentionally, no reference is made of muddy bottoms in this definition, so that it might also be applied to hard bottom configurations that could be subject to uncertainties about the lowest level (e.g. rocky bottom channel with large boulders, coral channel with outcrops, sandy bottom with sand waves). In these cases, 'damage' caused by contact between the ship and the *nautical bottom* is more realistic than in the case of a muddy bottom, where it is more likely that the forces exerted by contact with mud will cause controllability problems rather than damage.

This definition for *nautical bottom* does not provide a ready-to-use practical solution, as no specification is made of the physical characteristic(s) on which the criterion is based. Furthermore, strict criteria for 'acceptable' ship behaviour are not available and depend on the local situation. Therefore, from a practical and operational point of view, implementation of the nautical bottom concept requires:

- A practical criterion (i.e. selection of the physical mud characteristics acting as a parameter for the nautical bottom approach and its critical value)
- A practical survey method to determine both the acceptable level and the water-mud interface in an efficient and reliable way
- A minimum value for the required UKC relative to this *nautical bottom* (see Appendix E)
- If required, either (a) a minimum value for the required UKC relative to the water-mud interface to ensure a minimal risk for contact and acceptable ship behaviour, or (b) a maximum value for the penetration of the keel into the mud layer if contact with the mud is considered to be acceptable according to the local conditions
- Knowledge about and training in ship behaviour in these situations, and if necessary, measures to compensate for adverse effects on controllability and manoeuvrability.

Nautical Bottom Recommendations

The implementation of the nautical bottom approach is recommended in waterways when fluid mud layers cover the bottom. An indication of the presence of fluid mud is a significant difference between the high and low frequency echo-soundings. Besides the nautical bottom level, the mud-water interface (determined by high frequency echo sounding) needs to be measured during bottom surveys. Pilots need to know the position of the keel relative to the mud layer to assess the effect on the ship's behaviour, to estimate the required tug assistance, etc. If ships are expected to penetrate the mud frequently, it is recommended that the feasibility and safety of the required manoeuvres be assessed by means of advanced simulation techniques.

Compared to the situation in which a mud layer is not present above the 'hard' bottom, **the mud layer always increases the maximum sinkage**. It is recommended that the water depth above the water-mud interface be used in squat formulae to include this effect.

Additional discussion of topics dealing with channels in muddy areas are contained in Appendix E and includes mud characteristics, criteria for determining *nautical bottom* and behaviour of ships in muddy areas.

2.2 Air Draught Clearance (ADC)

The discussion so far has been concerned with clearances within the water column. The air draught clearance *ADC* is concerned with vertical clearances above the water surface. It involves vertical distances between the top of the ship and overhead structures, such as bridges, power lines, cables, etc. This is a similar concept as the *UKC* is for the clearance in the water column between the bottom of the channel and the ship. Figure 2.6 illustrates the two basic definitions for air draughts: (a) H_{kt} is the height of the ship from keel to top mast and (b) H_{st} is air draught or height from the sea or water surface to top mast [Takahashi, 2007]. The water surface is equivalent to the highest navigable water level in this application. Although the H_{kt} height is a unique value for a ship, the air draught H_{st} varies greatly depending on the value of ship draught T . In summary, H_{st} is a function of the ship loading, overall height of the ship and variable water levels due to tides and meteorological effects. For safety reasons, there should always be a positive *ADC* between the top of the ship and the bottom of any overhead structure, attached equipment and other suspended facilities. Additional air draught information is provided in Appendix F.

As an example, present regulations for the Panama Canal state the allowable height H_{st} for any vessel transiting the Canal or entering the Port of Balboa is 57.91 m (190 ft) at any state of the tide, measured from the waterline to the highest point on the ship. Height may be permitted to 62.48 m (205 ft), subject to approval of the Authority on a case-by-case basis, with passage at low water (MLWS) beneath the bridge at Balboa.

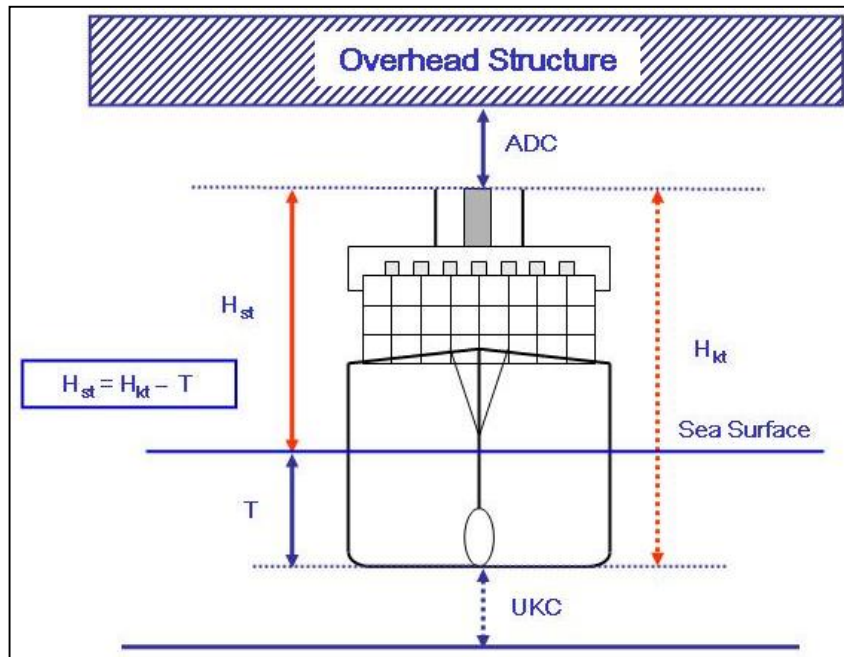

Figure 2.6: Air draught relationships [Takahashi, 2007]

Note that the 'Sea Surface' is equivalent to the 'Highest Navigable Water Level'

2.3 Concept Design – Vertical Dimensions

The third major section in this chapter discusses the *Concept Design* (CD) stage for deep-draught channels. It is intended for use in early design and trade-off studies and should be rapid in execution without excessive input data requirements. The CD method represents good modern practice and channels designed to this method should result in a conservative design with an adequate level of navigational safety.

2.3.1 Design Water Level

It is generally best to divide long access channels or rivers into several stretches with corresponding ship, tidal and local conditions that match the appropriate design water level.

2.3.2 Ship-Related Factors (F_s)

Ship related factors are the most important in vertical channel design. Apart from ship draught T , the ship factors can be estimated separately for ship squat, dynamic heel and wave response allowance or combined together. Rather than estimating each one separately, a simpler approach for the CD stage of design is to combine them into one ship related factor F_s that includes all of these ship effects. An approximation depends on ship speed, intensity of wave effects on the design ship with its maximum draught T and type of channel (Table 2.2).

Description	Vessel Speed	Wave Conditions	Channel Bottom	Inner Channel	Outer Channel	
Ship Related Factors F_s						
Depth h	≤ 10 kts	None		$1.10 T$		
	10 - 15 kts			$1.12 T$		
	> 15 kts			$1.15 T$		
	All	Low swell ($H_s < 1$ m)			$1.15 T$ to $1.2 T$	
		Moderate swell ($1 \text{ m} < H_s < 2 \text{ m}$)			$1.2 T$ to $1.3 T$	
		Heavy swell ($H_s > 2 \text{ m}$)			$1.3 T$ to $1.4 T$	
	Add for Channel Bottom Type					
	All	All	Mud	None	None	
Sand/clay			0.4 m	0.5 m		
Rock/coral			0.6 m	1.0 m		
Air Draught Clearance (ADC)						
ADC	All	All		$0.05 H_{st}$	$0.05 H_{st}$ + $0.4 T$	
Notes: <ol style="list-style-type: none"> 1. For Ship Related Factors: Assumes $T > 10$ m. If $T < 10$ m, use value for $T = 10$ m 2. Swell means waves with peak periods T_p greater than 10 s 3. For Outer Channel swell values, use lower value for smaller swell wave periods and higher value for larger swell periods 4. Value of significant wave height H_s is dependent on required operation, design ship type, level of accessibility, wave period and relative wave direction 5. H_{st} is the distance from the sea surface to the top of the ship 6. Seawater density assumed for T. Additional adjustments required if fresh water. 						

Table 2.2: Channel depth components and air draught estimates for Concept Design (CD)

If the design ship in the CD stage is a container ship or car carrier, it is a good idea to include a separate estimate for dynamic heel. Container ships and car carriers are especially prone to heeling by strong crosswinds (low \overline{GM} , see Appendix Table C-3). A conservative estimate of a roll angle due to turning and windage is $\phi_{WR} = 1$ to 2 deg. The equivalent sinkage of the ship bilge keel S_K is given by:

$$S_K = F_K \left(\frac{B}{2} \sin \phi_{WR} \right) \quad (2-8)$$

where F_K is a bilge keel factor that takes into account the significant curvature of the bilge keel (especially in Post-Panamax ships). A typical value of $F_K \approx 0.76$ to 0.90, but the larger value is a safer, more conservative estimate. This S_K value should be compared with the calculations above and included if it is a significant portion of the allowance for ship squat and wave motions, say greater than 5 %.

2.3.3 Air Draught Clearance (ADC)

So far we have been concerned with the vertical clearance under the ship. In this case, the deepest draught ship usually presents the worst-case scenario. For concept design of overhead structures, however, the light-loaded ship presents the worst-case scenario since it will have the largest air draught to pass safely under a fixed overhead structure

(i.e. an operational issue). Thus, the design ship for air draught is probably different from the design ship for channel depth.

A simple estimate of the required air draught clearance ADC to cover uncertainties in ship draught and vertical movements during passage under bridges, power lines and near airports is:

$$ADC = 0.05H_{st} \geq 2 \text{ m} \quad (2-9)$$

Therefore, the clearance between the top of the ship and the bottom of an overhead structure should be equal to or greater than 5 % of H_{st} , but not less than 2 m for inner channels (see Table 2.2). For outer channels where wave conditions can be significant, an additional allowance equal to $0.4T$ should be included.

When the use of tidal windows or high tides for ship transit are significant, calculation of ADC should allow for the highest probable navigable water level (e.g. high water datum such as HAT and/or tidal surge), unlike calculations for channel depth that typically use LAT (or equivalent low water datum).

Note that power lines may sag due to age, ice, snow, temperature, etc. and may require additional allowances. Finally, additional clearance should be provided to prevent arcing of power lines that might occur if the ship is too near to the line.

2.3.4 Concept Design Example Problems

The CD water depth h_{CD} is given as the sum of F_s and S_K by:

$$h_{CD} = F_s + S_K \quad (2-10)$$

Note that F_s includes a value for type of channel bottom.

For our purposes the total air draught height H_a is measured from the keel of the ship relative to the water level and the reference level (Chart Datum) to the bottom of the overhead structure. This is somewhat different from the structural design of the overhead structure where the distance above the sea surface relative to the Chart datum is required. The H_a is the sum of T , H_{st} , and ADC given by (see Figure 2-6):

$$H_a = T + H_{st} + ADC \quad (2-11)$$

Be sure to check for the draught of the ship and the water levels in these calculations. Several examples are presented to illustrate the application of the CD stage predictions for different ship and channel conditions.

2.3.4.1 Example 1: Finland, General Cargo Ship

The first CD example is a general cargo ship typical of those in Finland. The inner channel has low wave conditions and hard bottoms. The ship has a draught $T = 10$ m and speed relative to the water $V_k = 14$ knots. The air draught from the sea surface to the top of the mast is $H_{st} = 48$ m. The hard channel bottom type requires a value of 0.6 m be added to F_s . Substituting these values into the equations for the concept design in Table 2.2 gives a value for the ship factor F_s :

$$F_s = 1.12T + 0.6 = 1.12(10) + 0.6 = 11.8 \text{ m} \quad (2-12)$$

For the Concept Design, all the allowances for channel depth are additive, without regard to phasing. In this example, however, S_K is not used since roll is not significant, so that h_{CD} is equal to F_s :

$$h_{CD} = F_s = 11.8 \text{ m} \quad (2-13)$$

Finally, the ADC is given by (subject to specific power cable factors in 2.3.3):

$$ADC = 0.05H_{st} = 0.05(48) = 2.4 \text{ m} \quad (2-14)$$

Note that the total height from the keel to the bottom of the overhead structure H_a is:

$$H_a = T + H_{st} + ADC = 10 + 48 + 2.4 = 60.4 \text{ m} \quad (2-15)$$

2.3.4.2 Example 2: Richards Bay, South Africa, Coal Bunker

The second CD example is a coal carrier typical of those in use in Richards Bay, South Africa. The outer channel is occasionally exposed to heavy 'shouldering' (i.e. bow quartering) swell conditions and has a sandy bottom (0.5 m). The ship has a draught of $T = 17.5$ m and speed in the outer channel of $V_k = 10$ knots. Again, substituting these values into the equations for the concept design in Table 2-2 gives a value for the ship factor F_s :

$$F_s = 1.4T + 0.5 = 1.4(17.5) + 0.5 = 25.0 \text{ m} \quad (2-16)$$

The CD channel depth h_{CD} is again equal to F_s since S_K is not used:

$$h_{CD} = F_s = 25.0 \text{ m} \quad (2-17)$$

For comparison, the actual channel depth after DD was $h = 24$ m below Chart Datum. Use of the outer channel by deep-draught ships was restricted to limiting wave heights, as a function of wave period and direction and tidal windows. As expected, the CD prediction is more conservative than the DD depth.

2.3.4.3 Example 3: Zeebrugge, Belgium, Container Ship

The third CD example is a container ship typical of those using the port of Zeebrugge, Belgium. The port lies on the Belgian North Sea coast, 10 km west of the Belgian-Dutch border. In the deep-draught *Pas van het Zand* channel, the significant wave height does not exceed 2.0 m in about 98 % of the observations, but shipping traffic should remain possible in wave heights between 2.0 to 3.0 m. However, low swell ($H_s < 1$ m) wave conditions are considered in this example since wind waves are dominant compared to swell. In addition, since the channel is located on the North Sea with relatively short swell wave periods, a ship factor $1.15 T$ is taken as a base. The channel has a width of 300 m, with a sandy bottom that requires the addition of 0.5 m.

The harbour is accessible for container ships with $L = 396$ m and $B = 56$ m, which have a maximum draught $T = 16$ m. The speed of these vessels in the channel is typically less than 10 knots. There are no overhead bridges or other structures, so air draught is not a

consideration. Substituting these values into the equations for the concept design in Table 2-2 gives an average value for the ship factor F_s .

$$F_s = 1.15T + 0.5 = 1.15(16) + 0.5 = 18.9 \text{ m} \quad (2-18)$$

Since this is a container ship, we will estimate a maximum roll angle sinkage due to turning and/or windage. The sinkage at the keel S_K for a roll angle $\phi_{WR} = 2$ deg is given by:

$$S_K = F_K \left(\frac{B}{2} \sin \phi_{WR} \right) = 0.9 \left(\frac{56}{2} \sin 2^\circ \right) = 0.9 \text{ m} \quad (2-19)$$

The CD channel depth h_{CD} in this example is the sum of the two components F_s and S_K , as:

$$h_{CD} = F_s + S_K = 18.9 + 0.9 = 19.8 \text{ m} \quad (2-20)$$

If we take into account the tidal range of more than 3 m at Zeebrugge, the channel could be designed for a tide-independent draught of $T = 14$ m, which is a more typical draught for container vessels. This would reduce the required channel depth:

$$h_{CD} = F_s + S_K = 16.6 + 0.9 = 17.5 \text{ m} \quad (2-21)$$

This value results from an average ship factor $F_s = 1.15T + 0.5$.

For comparison, present practice in the *Pas van het Zand* channel requires a Gross UKC (i.e. h/T) of 12.5 %. The channel depth is maintained at $h = 15.8$ m referred to LAT, which implies a tide-independent draft of $15.8/1.125 = 14.0$ m. Therefore, it can be concluded that the CD method results in a very conservative value as a value of $h_{CD} = 15.8$ m is satisfactory according to present practice whereas the CD requires a 17.5 m value. If the 0.9 m extra sinkage due to heel is omitted, the required depth is 16.6 m; which is still rather conservative compared to the actual practice of 15.8 m, but acceptable as a concept design value.

2.3.4.4 Example 4: Panama Canal, Tanker

The fourth and last CD example is a tanker typical of those using the Panama Canal. The Panama Canal has no waves (like an inner channel) and has hard and soft bottoms. A soft sand or clay (0.4 m) bottom section is used for this example. Typical tankers have a draught $T = 11.3$ m, $B = 32.2$ m, and speed $V_k = 6$ knots. Air draught from the sea surface to the top of the mast is $H_{st} = 40$ m. Again, substituting these values into the equations for the concept design in Table 2-2 gives a value for the ship factor F_s :

$$F_s = 1.1T + 0.4 = 1.1(11.3) + 0.4 = 12.8 \text{ m} \quad (2-22)$$

The CD channel depth h_{CD} is again equal to F_s as S_K is not required:

$$h_{CD} = F_s = 12.8 \text{ m} \quad (2-23)$$

Finally, the ADC is given by:

$$ADC = 0.05H_{st} = 0.05(40) = 2.0 \text{ m} \quad (2-24)$$

The total height from the keel to the bottom of the overhead structure H_a is:

$$H_a = T + H_{st} + ADC = 11.3 + 40 + 2 = 53.3 \text{ m} \quad (2-25)$$

The Panama Canal has a special requirement that the maximum allowable $H_{st} = 57.91 \text{ m}$, so we are okay since the tanker's H_{st} is within this tolerance.

2.4 Detailed Design – Vertical Dimensions

This section describes the Detailed Design (DD) stage. This stage is inherently more complicated than the Concept Design (CD) stage and involves the use of empirical methods and numerical or physical models to ensure more realistic accuracy for final design. These methods are the 'building blocks' for the Probabilistic Design (PD) that is discussed in the last section in this chapter.

2.4.1 Water Level Factors

Apart from the factors described in Sections 2.1.1 and 2.3.1, one will probably need a tidal prediction model to compare conditions with and without the channel. Modifications of the channel dimensions may lead to different tidal water levels, especially if the geometry and water depth change significantly.

2.4.2 Ship Factors

Ship squat, dynamic heel, and wave response allowance continue to be the most significant ship factors. Each is described in the paragraphs below.

2.4.2.1 Squat (S_{Max})

One or more of the PIANC empirical formulas described in Appendix D should be compared and examined to obtain a reasonable estimate of maximum bow or stern squat S_{Max} , being especially careful to select formulas that satisfy ship and channel constraints. Extensive examples are contained in Appendix D. For all channel configurations, the simplest formulas are the Barrass (2002) and Yoshimura (1986). For open or unrestricted channel configurations, the ICORELS (1980) has historically been a good choice. The Eryuzlu2, Huuska/Guliev and Römisch formulas are the most complex. This comparison might include some statistics on the minimum, average and maximum squat values to bracket the range of values and to provide some guidance on the relative accuracy of one prediction over another. If the project has time and funding, a physical and/or numerical model can be constructed and tested to validate and verify the PIANC predictions, especially for the newer generation ships with larger dimensions.

2.4.2.2 Dynamic Heel (Z_{WR})

When a ship turns in wind, it experiences heel and associated bilge keel sinkage. The estimated vertical motions in these conditions can be compared to the estimates for maximum vertical ship motions Z_{Max} due to normal ship motions in waves (see below). The ship bilge keel sinkage due to turning in windy conditions Z_{WR} (i.e. both turning and wind forces) is a function of the ship's heel and can be calculated as:

$$Z_{WR} = F_K \left(\frac{B}{2} \sin \phi_{WR} \right) \quad (2-26)$$

where B denotes the ship's beam. Note the similarity of this equation with Eq. 2-8. The heel angle ϕ_{WR} is composed of two components given as:

$$\phi_{WR} = \phi_W + \phi_R \quad (2-27)$$

where ϕ_W is the heel angle due to wind forces and ϕ_R is the heel angle due to ship turning.

Heel Angle Due to Wind Forces

The heel angle due to wind forces ϕ_W may be calculated as:

$$\phi_W = \frac{M_W}{\Delta \overline{GM}} = \frac{M_W}{\gamma_w \nabla \overline{GM}} \quad (2-28)$$

where Δ is the ship's weight displacement in seawater (kN), ∇ the ship's volume displacement (m^3), $\gamma_w = g\rho_w$ the specific weight of seawater (10.06 kN/m^3) and ρ_w the density (specific mass) of seawater ($1,025 \text{ kg/m}^3$ or 1.025 tonnes/m^3). Estimates of \overline{GM} are listed in Appendix C, Table C-3 for a range of ship types or can be approximated by Eq. 2-5.

The wind heel moment M_W (N·m) may be estimated by:

$$M_W = \ell_w F_{Wy} \quad (2-29)$$

where:

$\ell_w = \overline{KG}_W - \frac{T}{2}$ = heel moment arm due to wind force (m), \overline{KG}_W = height of the centre of windage lateral area measured from the keel (m), and T = ship's draught (m). The wind lateral force F_{Wy} (N) in the y -direction is defined as:

$$F_{Wy} = \frac{1}{2} \rho_a C_{Wy} A_{V,L} V_{WR}^2 \quad (2-30)$$

where:

ρ_a = density of air (1.25 kg/m^3 , at 10 deg C),
 $A_{V,L}$ = projected side area above waterline or lateral windage (m^2),
 V_{WR} = relative wind speed (m/s).

The wind force coefficient C_{Wy} is a function of the angle of the relative wind direction θ_{WR} at the centre of gravity of the ship. It is usually estimated by regression equations based on wind tunnel tests. Yamano and Saito (1997) developed an equation based on a trigonometric series given by:

$$C_{Wy} = \sum_{n=1}^3 C_{Yn} \sin(n\theta_{WR}) \quad (2-31)$$

The three regression coefficients C_{Yn} for $n = 1, 2, 3$ are given as:

$$C_{Yn} = C_{Yn0} + C_{Yn1} \frac{A_{V,L}}{L_{pp}^2} + C_{Yn2} \frac{x_L}{L_{pp}} + C_{Yn3} \frac{L_{pp}}{B} + C_{Yn4} \frac{A_{V,L}}{A_{V,F}} \quad n = 1, 2, 3 \quad (2-32)$$

where:

$A_{V,F}$ = projected frontal area above the waterline or transverse windage (m^2) and
 x_L = distance between the forward perpendicular and the centre of $A_{V,L}$ (m).

Table 2-3 lists the front and lateral area coefficients for estimating $A_{V,F}$ and $A_{V,L}$ cross-sectional windage for eight ship types using the equation below:

$$Y = \alpha X^\beta \quad (2-33)$$

where $Y = A_{V,F}$ or $A_{V,L}$, $X = DWT$ or GT depending on ship type listed in the table and α and β are based on selected windage Y . These coefficients are based on 95 % confidence limits calculated by Akakura and Takahashi (1998) for fully-loaded conditions from Lloyd's Register of Ships (1995.6).

Finally, the five empirical coefficients C_{Yn0} to C_{Yn4} for $n = 1, 2, 3$ are listed in Table 2.4. Additional details can be found in Yamano and Saito (1997).

Ship Type (Fully-loaded)	X	$A_{V,F}$ Front Area Coefficients		$A_{V,L}$ Lateral Area Coefficients	
		α	β	α	β
Cargo Ship	DWT	0.592	0.666	3.213	0.616
Bulk Carrier	DWT	8.787	0.370	16.518	0.425
Container ship	DWT	1.369	0.609	2.614	0.703
Tanker	DWT	2.946	0.474	3.598	0.558
RoRo Ship	DWT	10.697	0.435	28.411	0.464
Passenger Ship	GT	8.842	0.426	3.888	0.680
Ferry Boat	GT	5.340	0.473	3.666	0.674
Gas Carrier	GT	2.649	0.553	5.074	0.613

Table 2.3: Windage coefficients for front $A_{V,F}$ and lateral $A_{V,L}$ cross-sectional areas based on 95% confidence limits [Akakura and Takahashi, 1998]

Coefficient n	Coefficient C_{Ynj} for $j = 0$ to 4				
	C_{Yn0}	C_{Yn1}	C_{Yn2}	C_{Yn3}	C_{Yn4}
1	0.509	4.904	0	0	0.022
2	0.0208	0.23	-0.075	0	0
3	-0.357	0.943	0	0.0381	0

Table 2.4: C_{Ynj} empirical coefficients for lateral wind forces

Heel Angle Due to Turning

In general, the amount of ship heel is a function of the rudder deflection. Immediately after rudder deflection, the ship rolls inward slightly due to the heel moment. This heel motion rapidly changes direction outward due to centrifugal force and then attains a peak

or maximum heel angle ϕ_{MAX} in the transient state. The ship finally reaches a steady turning condition with heel angle ϕ_C , which may be obtained by the following equation:

$$\phi_C = \frac{\ell_R U_C^2}{g R_C \overline{GM}} \quad (2-34)$$

where:

$$\ell_R = \overline{KG} - \frac{T}{2} = \text{heel moment arm due to ship turning (m),}$$

\overline{KG} = height of the ship centre of gravity as measured from the keel (m),

U_C = ship speed at steady turning (m/s) and

R_C = steady turning radius (m).

The \overline{KG} is defined by the relationship:

$$\overline{KG} = \overline{KB} - \overline{GM} + \overline{BM} \quad (2-35)$$

where:

\overline{KB} = height of the ship centre of buoyancy as measured from the keel (m),

\overline{BM} = distance between the centre of buoyancy and metacentric height (m).

The \overline{KB} can be estimated by:

$$\overline{KB} = T \left(0.84 - \frac{0.33 C_B}{0.18 + 0.87 C_B} \right) \quad (2-36)$$

Finally, the \overline{BM} can be predicted using:

$$\overline{BM} = \frac{I_T}{\nabla} = \left(\frac{\pi L_{pp} B^3}{64} \right) \left(\frac{1}{C_B L_{pp} B T} \right) = \frac{B^2}{20.4 C_B T} \quad (2-37)$$

where:

I_T = inertia moment of flotation area (m⁴) and

The steady turning radius R_C (m) may be obtained by the following equation as:

$$R_C = \frac{L_{pp}}{K_T \delta_R} \quad (2-38)$$

where δ_R = rudder angle (rad). Values of the non-dimensional index of turning ability K_R are listed in Table 2-5 for 13 ship types and sizes. These values were obtained using mathematical simulation for calm water with no wind and 20 deg rudder angle conditions. Additional details and values for R_C are contained in Chapter 3.

The maximum heel angle due to ship turning ϕ_R may be estimated as:

$$\phi_R = \phi_{MAX} = C_\phi \phi_C \quad (2-39)$$

where the coefficient C_ϕ depends on the magnitude of rudder angle and is in the range of 1.3 to 1.7 for turning with 10 to 20 deg rudder, respectively.

As an additional remark, it is noted that ships with high \overline{KG} and/or small \overline{GM} , such as container ships and RoRo ships, may experience large heel angles in some situations during turning in wind.

No.	Ship Type	Ship Size	K_R
1	Cargo ship	Medium	0.58
2		Small	0.47
3	Container ship	Post-Panamax	0.42
4		Panamax	0.52
5	Bulk Carrier	Very large	0.52
6		Panamax	0.49
7		Small	0.62
8	VLCC		0.62
9	Tanker	Small	0.60
10	LNG Carrier		0.75
11	Refrigerated Cargo		0.63
12	Passenger Ship		0.66
13	Ferry Boat		0.55

Table 2.5: K_R values in shallow water for $h/T = 1.2$ [MLIT, 2007 ; OCDI, 2009]

Examples for Dynamic Heel (Z_{WR})

Example problems are presented for heel angles due to wind only, turning only, and combined wind and turning.

Heel Angle due to Wind Forces Only

The first example is for the heel angle due to wind forces. The design ship is a newer generation Post-Panamax container ship. From Table C-1 in Appendix C: TEU = 18,000, $L_{oa} = 400$ m, $L_{pp} = 385$ m, $B = 59$ m, $T = 16.5$ m and $C_B = 0.68$. We assume that the relative wind speed $V_{WR} = 25$ knots (i.e. 12.9 m/s) is blowing normal or perpendicular to the side of the ship.

The first step is to gather the remaining input parameters by making some assumptions. We can use the coefficients in Table 2.3 to estimate the two cross-sectional areas $A_{V,L}$ and $A_{V,F}$ according to the equation:

$$\begin{aligned} A_{V,L} &= \alpha_S (DWT)^{\beta_S} = 2.614(200000)^{0.703} = 13969 \text{ m}^2 \\ A_{V,F} &= \alpha_F (DWT)^{\beta_F} = 1.369(200000)^{0.609} = 2316 \text{ m}^2 \end{aligned} \quad (2-40)$$

The final input parameter x_L can be assumed to be equal to half of the L_{pp} , or $x_L = 192.5$ m.

The second step is to calculate the ratios in Eq. 2-32. These are given as:

$$\begin{aligned} \frac{A_{V,L}}{L_{pp}^2} &= \frac{13,969}{(385)^2} = 0.09; & \frac{x_L}{L_{pp}} &= \frac{192.5}{385} = 0.5 \\ \frac{L_{pp}}{B} &= \frac{385}{59} = 6.5; & \frac{A_{V,L}}{A_{V,F}} &= \frac{13,929}{2,316} = 6.0 \end{aligned} \quad (2-41)$$

The third step is to substitute these ratios and the five empirical coefficients in Table 2.4 into Eq. 2-32 to obtain the three regression coefficients C_{Yn} for $n = 1$ to 3 as:

$$\begin{aligned} C_{Y1} &= 0.509 + 4.904(0.09) + 0(0.5) + 0(6.5) + 0.022(6.0) = 1.10 \\ C_{Y2} &= 0.0208 + 0.23(0.09) - 0.075(0.5) + 0(6.5) + 0(6.0) = 0.005 \\ C_{Y3} &= -0.357 + 0.943(0.09) + 0(0.5) + 0.0381(6.5) + 0(6.0) = -0.02 \end{aligned} \quad (2-42)$$

In Step 4, we substitute these three regression coefficients into Eq. 2-31 for a relative wind direction $\theta_w = 90$ deg to estimate the C_{Wy} coefficient given by:

$$C_{Wy} = C_{Y1} \sin(90) + C_{Y2} \sin(2 * 90) + C_{Y3} \sin(3 * 90) = 1.12 \quad (2-43)$$

where we converted θ_w to radians.

The next step is to estimate the lateral wind force F_{Wy} in Eq. 2-30 for a relative wind speed $V_{WR} = 25$ knots = 12.9 m/s as:

$$F_{Wy} = \frac{\rho_a C_{Wy} A_{V,L} V_{WR}^2}{2} = \frac{(1.25)(1.12)(13969)(12.9)^2}{2} = 1615\,569\text{N} = 1616\text{ kN} \quad (2-44)$$

Step 6 requires the estimation of the heeling moment M_W from Eq. 2-29. First, we need to estimate the mean height of the superstructure and cargo above the waterline, as projected onto a longitudinal plane. This is estimated as:

$$G + h_s = \frac{A_{V,L}}{L_{pp}} = \frac{13\,929}{385} = 36.2\text{ m} \quad (2-45)$$

where G is the freeboard from the waterline to the top of the deck and h_s is the mean height of the superstructure and cargo above the deck. Next, the centre of windage above the keel \overline{KG}_W is given by:

$$\overline{KG}_W = T + (G + h_s) / 2 = 16.5 + 36.2 / 2 = 34.6\text{ m} \quad (2-46)$$

Then, the moment arm ℓ_W is:

$$\ell_W = \overline{KG}_W - T / 2 = 34.6 - 16.5 / 2 = 26.3\text{ m} \quad (2-47)$$

Finally, we substitute this into the equation for M_W :

$$M_W = \ell_W F_{Wy} = 26.3(1616) = 42\,554\text{ kNm} \quad (2-48)$$

In step 7, we estimate the heel angle ϕ_w from Eq. 2-28. First, we need to estimate the ship's volume displacement in seawater ∇ given by:

$$\nabla = C_B L_{pp} B T = 0.68(385)(59)(16.5) = 254\,862\text{ m}^3 \quad (2-49)$$

Next, we estimate the \overline{GM} from the Table C-3 approximation as:

$$\overline{GM} = 0.125T = 0.125(16.5) = 2.1 \text{ m} \quad (2-50)$$

Then, we substitute these values to obtain an estimate of ϕ_W as:

$$\phi_W = \frac{M_W}{\gamma_w \nabla \overline{GM}} = \frac{42,554}{10.06(254\,862)(2.1)} \left[\frac{180 \text{ deg}}{3.14 \text{ rad}} \right] = 0.5 \text{ deg} \quad (2-51)$$

where we converted volume displacement ∇ in m^3 to weight displacement Δ in kN.

Finally, in the last step we calculate the sinkage Z_W due to wind forces only from Eq. 2-26 as:

$$Z_W = F_K \left[\frac{B}{2} \sin(\phi_W) \right] = 0.9 \left[\frac{59}{2} \sin(0.5) \right] = 0.2 \text{ m} \quad (2-52)$$

where we used $F_K = 0.90$ as the bilge keel factor.

Heel Angle due to Turning Only

The second example is for the heel angle due to turning ϕ_R . We will use the same ship with a rudder angle $\delta_R = 20 \text{ deg}$ (0.349 rad) and a ship speed in turning of $U_C = 12 \text{ knots}$ (i.e. 6.2 m/s).

In step 1, we estimate the height of the ship centre of gravity from the keel \overline{KG} using Eq. 2-35. First, we estimate \overline{KB} and \overline{BM} from Eqs. 2-36 and 2-37 as:

$$\overline{KB} = 16.5 \left(0.84 - \frac{0.33 * 0.68}{0.18 + 0.87 * 0.68} \right) = 9.1 \text{ m} \quad (2-53)$$

$$\overline{BM} = \frac{B^2}{20.4 C_B T} = \frac{59^2}{20.4 * 0.68 * 16.5} = 15.2 \text{ m} \quad (2-54)$$

$$\overline{KG} = \overline{KB} - \overline{GM} + \overline{BM} = 9.1 - 2.1 + 15.2 = 22.2 \text{ m} \quad (2-55)$$

The second step is to calculate the turning radius R_C given in Eq. 2-38 as:

$$R_C = \frac{L_{pp}}{K_R \delta_R} = \frac{385}{0.42(0.349)} = 2\,626 \text{ m} \quad (2-56)$$

where $K_R = 0.42$ from Table 2-5.

Step 3 involves calculating the heel moment arm due to ship turning ℓ_T as:

$$\ell_T = \overline{KG} - \frac{T}{2} = 22.2 - \frac{16.5}{2} = 14.0 \text{ m} \quad (2-57)$$

In Step 4, we estimate the heel angle due to turning ϕ_C from Eq. 2-34 as:

$$\phi_C = \frac{\ell_T U_C^2}{g R_C GM} = \frac{14.0(6.2)^2}{9.81(2626)(2.1)} = 0.6 \text{ deg} \quad (2-58)$$

If we assume the worst-case value for the coefficient $C_\phi = 1.7$, we get the maximum heel angle due to ship turning $\phi_R = \phi_{Max}$ from Eq. 2-39 as:

$$\phi_R = \phi_{Max} = C_\phi \phi_C = 1.7(0.6) \approx 1.0 \text{ deg} \quad (2-59)$$

As before for the wind forces, we calculate the sinkage Z_R due to ship turning only from Eq. 2-26 as:

$$Z_R = F_K \left[\frac{B}{2} \sin(\phi_T) \right] = 0.9 \left[\frac{59}{2} \sin(1.00) \right] \approx 0.5 \text{ m} \quad (2-60)$$

Combined Dynamic Heel

Combining the two heel angles due to wind and turning according to Eq. 2-27, we obtain the total heel angle ϕ_{WR} as:

$$\phi_{WR} = \phi_W + \phi_R = 0.5 + 1.0 = 1.5 \text{ deg} \quad (2-61)$$

Finally, the combined sinkage due to wind and turning Z_{WR} is given as:

$$Z_{WR} = F_K \left[\frac{B}{2} \sin(\phi_{WR}) \right] = 0.9 \left[\frac{59}{2} \sin(1.5) \right] = 0.7 \text{ m} \quad (2-62)$$

2.4.2.3 Wave Response Allowance (Z_{Max})

As discussed previously, the wave response allowance is composed of the wave-induced ship motions due to the three vertical components of heave, roll and pitch. The wave response is due to the limiting operational wave event, not an extreme wave condition when a ship would not normally be entering or exiting an approach channel. Four methods for calculating wave-induced motions are discussed in this section. They include (a) quick trigonometric method to estimate wave-induced motion, (b) Japanese method based on the worst combination of motions, (c) Spanish ROM 3.1 semi-probabilistic method and (d) probabilistic-based method for estimating the expected maximum wave-induced ship motions

Trigonometric Method for Wave-Induced Vertical Motions ($Z_{Max,1}$)

This simplistic method for estimating wave-induced motions $Z_{Max,1}$ is based on trigonometry and assumes that the ship length L_{pp} is equal to half of the wavelength λ and its beam B is half of the λ . The total wave allowance $Z_{Max,1}$ is given by:

$$Z_{Max,1} = 1.2(H_{max})_p \approx 2H_s \quad (2-63)$$

where $(H_{max})_p$ is the maximum wave height whose exceedance probability is 'p' and H_s is the significant wave height. $Z_{Max,1}$ is composed of 20 % in heave, 50 % in roll and 50 % in pitch. The heave component is based on the assumption that the ship would move vertically a distance equal to the centroid of a half-sine wave. Both roll and pitch are assumed to move a vertical distance equivalent to $H_s/2$.

As a cross check, one can also estimate roll and pitch using the formulae below. The roll Z_ϕ assumes a maximum roll angle $\phi_{Max} = 5$ deg and is defined as:

$$Z_\phi = 0.5B \sin \phi_{Max} = 0.044B \quad (2-64)$$

Similarly, pitch Z_θ assumes a maximum pitch angle $\theta_{Max} = 1$ deg so that the pitch component is given by:

$$Z_\theta = 0.5L_{pp} \sin \theta_{Max} = 0.0087L_{pp} \quad (2-65)$$

These two components are added together to obtain a crosscheck on $Z_{Max,1}$ given as:

$$Z_{Max,1} = Z_\phi + Z_\theta \quad (2-66)$$

Of course, this is overly simplified since it is unlikely that wave components would all occur in phase, so it is considered conservative.

Japanese Method for Wave-Induced Vertical Motions ($Z_{Max,2}$)

In Japan the worst or largest motions are assumed to occur due to combined motions from heave and pitch at the bow Z_2 (Figure 2.7a), and heave and roll at the port and starboard bilge keels Z_3 (Figure 2.7b). Japanese researchers [Ohtsu et al., 2006 ; MLIT, 2007] have proposed a procedure for estimating these Z_2 and Z_3 vertical wave-induced motions. An example is presented that illustrates the four relatively straightforward steps in this method.

Step 1: Setting Design Conditions

The first step is to select the type of design ship and characteristics as shown in Table 2.6. The block coefficient C_B can be calculated based on the parameters of the design ship using the tables in Appendix C. In the navigation environment, required inputs include the operational ship speed V_s , the significant wave height $H_{1/3}$ and period $T_{1/3}$, the depth of water in the channel h , and the encounter angle ψ between the ship's heading and the wave direction.

Step 2: Calculation of Wave-Induced Vertical Motion at the Bow Z_2

Figure 2.8 is an example of computations for bow sinkage Z_2 for a cargo ship due to heave and pitch. Dimensionless bow sinkage Z_2/a_w (the ratio of bow sinkage to wave amplitude) is shown as a function of $\sqrt{L_{pp}/\lambda}$ for various wave direction angles ψ . Generally, waves come from various directions with various wavelengths. Newton's equations were used to predict ship motions, with hydrodynamic forces acting on the ship's hull as a function of the circular encounter frequency ω_E . It can be seen from this figure that bow sinkage can be more than three times the wave amplitude in a worst-case wave condition of $L_{pp}/\lambda = 1$ and $\psi = 30$ deg.

Although the motion characteristics shown in Figure 2.8 are obtained for a cargo ship with $C_B = 0.7$ at relative ship speed $F_{nL} = V_s / \sqrt{gL_{pp}} = 0.1$, these results are typical for the bow

sinkage of other type of ships. The user will want to use 'strip' or other suitable theory to calculate the ship motions for their particular ship and application. Additional details on the Japanese method are contained in MLIT (2007) and Takaki (1977). Therefore, this figure can be used as a first estimate of Z_2 . The bow sinkage estimates can be used to obtain reasonable estimates for conditions where $\sqrt{L_{pp}/\lambda} < 1.5$, or where $\lambda > 0.45L_{pp}$. Furthermore, bow sinkage derived from Figure 2.8 is obtained for deep water conditions which yields conservative values for channel depth design, since it may be generally accepted that bow sinkage in shallow water will be less than in deep water.

Step 3: Calculation of Wave-Induced Vertical Motion at the Bilges Z_3

The third step is to estimate the wave-induced vertical motion at the bilges Z_3 due to ship's heave and roll. It generally has a sharp peak at the resonant period, where $T_R = T_E$ (the natural roll period equals the encounter wave period). The bilge sinkage Z_3 (m) at T_R can be estimated as:

$$Z_3 = 0.7 \frac{H_s}{2} + \frac{B}{2} \sin \phi_{Max} \tag{2-67}$$

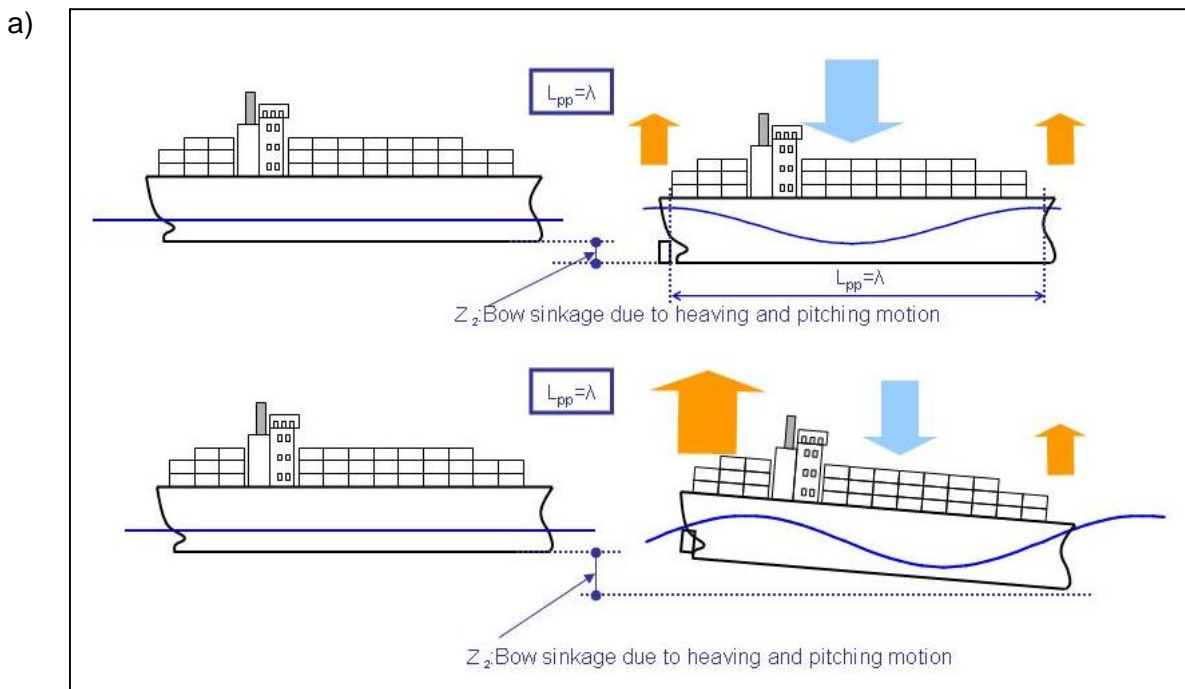

b)

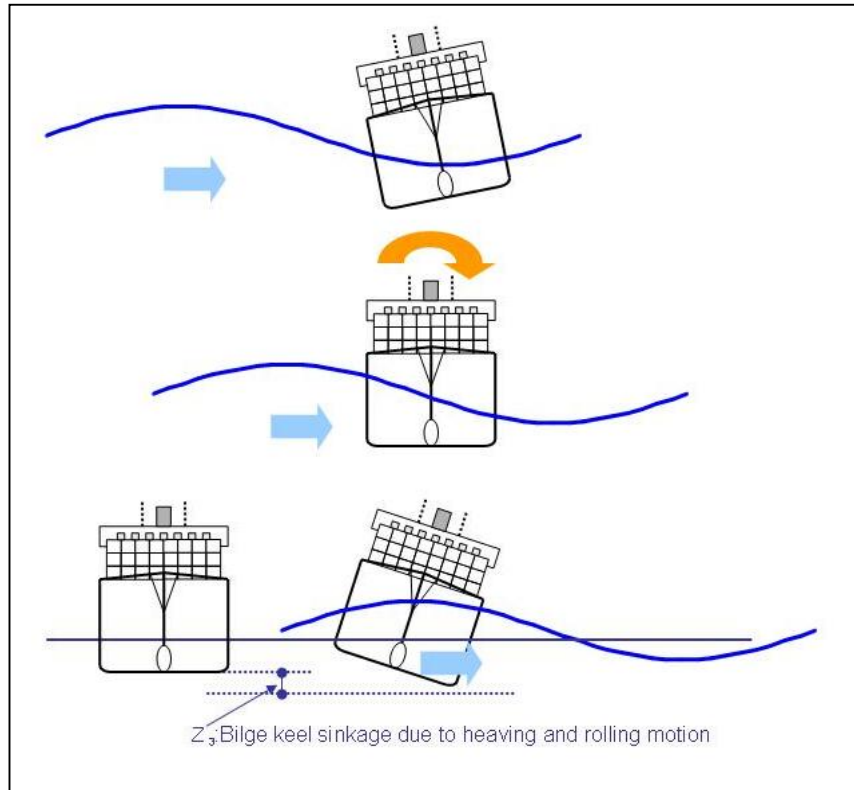

Figure 2.7: (a) Bow sinkage due to heave and pitch, (b) bilge keel amidships sinkage due to heave and roll [MLIT, 2007]

Category	Input Parameter
Design	New design
Fairway/channel	Existing fairway, new ship
Design vessel	Type of ship
	L_{oa} & L_{pp} = Lengths, B = beam, T = draught
	C_B = Block coefficient
Navigation environment	V_s = Ship speed in m/s
	$H_{\frac{1}{3}}$, $T_{\frac{1}{3}}$ = Significant wave height and period
	h = Depth of water in the channel. Note that the outside depth is required for calculating the ship length to wavelength ratio.
	Ψ = Encounter angle between the vessel's heading vector and the wave propagation vector

Table 2.6: Required input for Detailed Design of channel depth [MLIT, 2007]

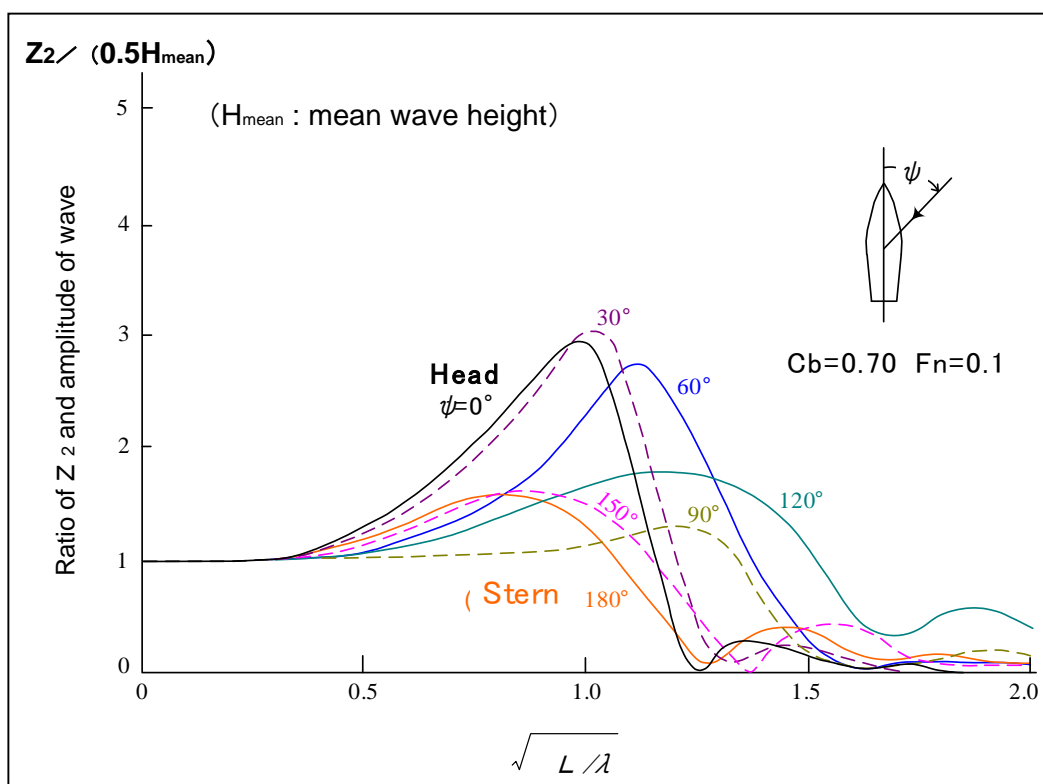

Figure 2.8: RAOs of bow sinkage Z_2 of a cargo ship due to heave and pitch, where $CB=C_b$, $FnL=Fn$, $L_{pp}=L$ [MLIT, 2007]

The maximum roll angle ϕ_{Max} (deg) is defined as:

$$\phi_{Max} = \mu\gamma\Phi \quad (2-68)$$

The wave slope angle Φ (deg) at T_R is:

$$\Phi = 360 \left[\frac{0.35H_s}{\lambda} \right] \sin\psi \quad (2-69)$$

where:

$H_s = H_{1/3}$ = significant wave height (m)

B = beam of the design ship (m)

μ = dimensionless rolling amplitude in regular waves

γ = effective wave slope coefficient, with $\mu * \gamma = 7$ as a maximum since this is a typical ship

In calculating Z_3 , it is essential to examine how close T_R is to T_E since roll increases rapidly when T_R coincides with T_E . The natural roll period T_R was estimated earlier in Section 2.1.2.6. Typical examples of channel depth determination using this procedure for a Panamax container ship of 59 500 DWT are shown in Figure 2.9. Contours of relative fairway depths to ship draught T for an approach angle $\psi = 60$ deg are shown as a function of $H_{1/3}$ and $T_{1/3}$. Of course, contours for other approach angles can also be calculated.

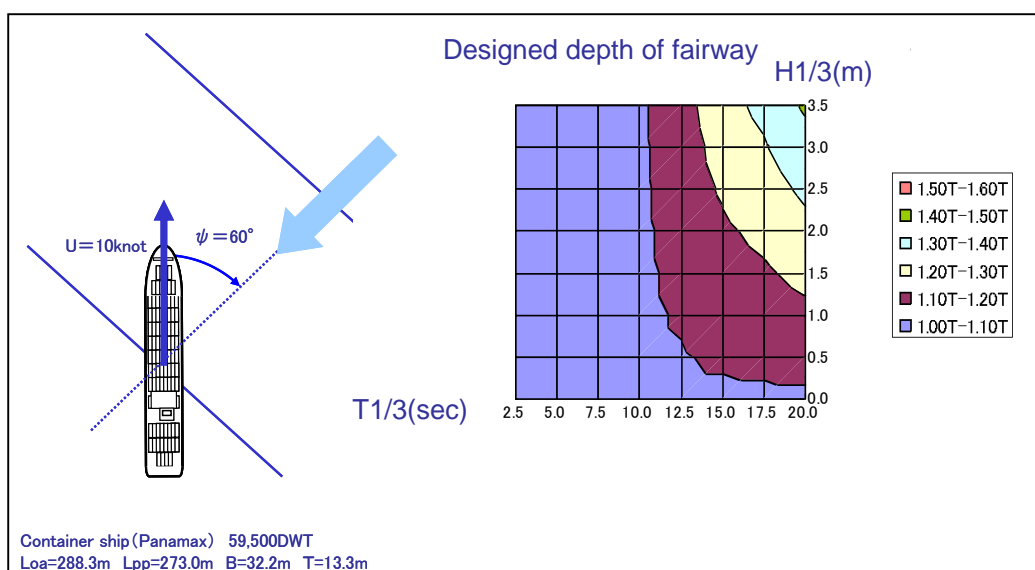

Figure 2.9: Channel depth calculations for Panamax container ship using the Japanese method for $\psi = 60$ deg [MLIT, 2007]

Step 4: Selection of the Maximum Value of Wave-Induced Vertical Motion ($Z_{Max,2}$)

The fourth and final step in the Japanese method is to select the maximum value of wave-induced sinkage $Z_{Max,2}$ from the calculated values of bow sinkage due to heave and pitch Z_2 , and bilge keel sinkage due to heave and roll Z_3 as:

$$Z_{Max,2} = \text{Max}(Z_2, Z_3) \quad (2-70)$$

Spanish ROM Method for Wave-Induced Vertical Motions ($Z_{Max,3}$)

The preferred method in Spain is based on the ROM 3.1. It is a semi-probabilistic method based on a partial coefficients methodology. Assumptions include ships that are (a) fully-loaded with over 90 % of their maximum displacement, (b) at rest or reduced speed with $F_{nh} \leq 0.05$, (c) $1.05 \leq h/T \leq 1.5$ and (d) wave direction aligned with the longitudinal axis within ± 15 deg. Six multiplicative factors account for variations in these assumptions. The wave-induced vertical motion allowance $Z_{Max,3}$ is defined as:

$$Z_{Max,3} = H_s C_1 C_2 C_3 C_4 C_5 C_6 \quad (2-71)$$

where H_s is the significant wave height or operational wave limit in metres and the six factors are explained in the following paragraphs. Note that the product of H_s times C_1 equals the maximum wave height $(H_{max})_p$. Also, the combination of the other five factors C_2 through C_6 is like a simplified RAO calculation. An example problem will be presented at the end to illustrate the procedure.

C_1 Maximum Wave Height Coefficient

The first factor C_1 is the 'maximum wave height coefficient' defined as:

$$C_1 = 0.707 \sqrt{\ln \left[\frac{N_w}{\ln(1/1 - P_m)} \right]} \quad (2-72)$$

where 'ln' is the natural log and N_w is the number of waves that a ship can expect to encounter in this area during each occurrence within the design life. Typical values for $N_w = 200$, with a maximum value of 10,000 if the ship is in an anchorage area. The exceedance probability for each occurrence or critical manoeuvre P_m is a function of the exceedance probability or acceptable failure probability during the design life P_{DL} and is defined as:

$$P_m = 1 - (1 - P_{DL})^{1/N_{Case}} \quad (2-73)$$

where N_{Case} is the number of critical cases during the design life. The value of N_{Case} is the total number of critical cases where wave operation limits might be reached for ships with maximum draught using the channel during the entire design life of 15 to 25 years. Reasonable values for P_{DL} range from 0.05 to 0.50.

C₂ through C₆ Coefficients

The second coefficient C_2 is the factor that accounts for variations in the ship vertical movements due to wave height, much like an RAO. Table 2.7 lists the range of values for the wave transformation coefficient C_2 as a function of H_s and L_{pp} . Intermediate values can be obtained by linear interpolation in the table. In general, the value of C_2 increases as H_s increases and L_{pp} decreases as a shorter ship responds to the waves more than a longer ship.

L_{pp} (m)	Significant Wave Height, H_s (m)							
	0.5	1.0	1.5	2.0	2.5	3.0	3.5	4.0
≤ 75	0.20	0.17	0.23	0.29	0.31	0.34	0.37	0.40
100	0.10	0.14	0.19	0.23	0.26	0.29	0.32	0.34
150	0	0.09	0.14	0.17	0.21	0.23	0.25	0.27
200	0	0.05	0.10	0.13	0.16	0.19	0.21	0.23
250	0	0.03	0.07	0.11	0.14	0.16	0.18	0.20
300	0	0	0.05	0.08	0.10	0.13	0.16	0.17
400	0	0	0.03	0.06	0.08	0.11	0.14	0.15

Table 2.7: C_2 wave transformation coefficient for semi-probabilistic method (courtesy ROM 3.1-99)

Table 2.8 lists the values and corresponding conditions for the other four coefficients C_3 through C_6 . The third coefficient C_3 is the load condition coefficient that accounts for changes in the ship displacement relative to the assumed 90 % loading condition. The fourth coefficient C_4 provides the adjustment due to ship speed as a function of F_{nh} . Coefficient C_5 adjusts for variations in water depth for h/T ratios from 1.05 to 1.50. The last coefficient C_6 is the wave-incidence angle adjustment (relative to the ship's longitudinal axis). The first two C_6 conditions are for bow or stern quartering seas and the third condition is for beam seas. Again, linear interpolation should be used for all coefficients for intermediate conditions that are between the listed conditions.

Symbol	Coefficient Name	Value	Condition
C ₃	Load Condition	1.00	Displacement ≥ 90%
		1.20	Displacement ≤ 50%
C ₄	Ship Speed	1.00	F _{nh} ≤ 0.05
		1.25	F _{nh} = 0.15
		1.35	F _{nh} ≥ 0.25
C ₅	Water Depth	1.00	h/T ≥ 1.50
		1.10	h/T ≤ 1.05
C ₆	Wave Incidence Angle	1.00	ψ ≤ 15 deg
		1.40	ψ = 35 deg
		1.70	ψ = 90 deg (Beam)

Table 2.8: C₃ to C₆ coefficients for semi-probabilistic method (courtesy ROM 3.1-99)

Example ROM 3.1 Problem

As an example, assume that 2,000 vessels use the channel each year. Of this number, only 10 % (assumed) have a maximum draught that poses a potential problem for the channel project depth. If one further assumes that only 20 % of this number will experience wave conditions from unfavourable directions where the wave operational limits are reached, we have a net of only 40 ships per year (i.e. 2 000 x 10 % x 20 %). If the design life of this channel is 15 years, then a total of $N_{Case} = 600$ ships represent critical cases during this design life. Finally, if we assign an acceptable failure probability during the design life $P_{DL} = 0.50$ for this soft bottom channel, we can estimate the exceedance probability for each critical case P_m using Eq. 2-73 as:

$$P_m = 1 - (1 - P_{DL})^{1/N_{Case}} = 1 - (1 - 0.50)^{1/600} = 1.154 * 10^{-3} \quad (2-74)$$

The next step is to estimate the C₁ wave height coefficient. The value of N_w can vary from 200 to 10,000. We will choose $N_w = 200$ for this example. Therefore, substituting into Eq. 2-72 we obtain C₁ = 2.46:

$$C_1 = 0.707 \sqrt{\ln \left[\frac{N_w}{\ln(1/1 - P_m)} \right]} = 0.707 \sqrt{\ln \left[\frac{200}{\ln(1/1 - 1.154 * 10^{-3})} \right]} = 2.46 \quad (2-75)$$

We next select an operational wave height $H_s = 2.5$ m, maximum design ship $L_{pp} = 300$ m, and displacement ≥ 90 %. From Table 2.7, we find that C₂ = 0.1. The corresponding values for the other four coefficients are obtained from Table 2.8 using the worst-case scenario of fast ship speed $F_{nh} \geq 0.25$, shallow water $h/T \leq 1.05$ and beam seas $\psi = 90$ deg. The four coefficients are C₃ = 1.0, C₄ = 1.35, C₅ = 1.1 and C₆ = 1.7. Finally, substituting these values into Eq. 2-71, we get $Z_{Max,3} = 1.55$ m.

$$Z_{Max,3} = H_s C_1 C_2 C_3 C_4 C_5 C_6 = 2.5 * 2.46 * 0.1 * 1.0 * 1.35 * 1.1 * 1.7 = 1.55 \text{ m} \quad (2-76)$$

Probabilistic-Based Method for Wave-Induced Vertical Motions (Z_{Max,4})

The fourth method for estimating the wave-induced vertical motions is a probabilistic-based method. In the probabilistic-based method, the interaction with all three vertical motions is included for all critical points on the ship, not just the extreme points at the ends or sides. By their very nature, waves have a stochastic nature and hence vertical

ship motions have a stochastic character. Wave heights in a wave field (space distribution) or a wave train (a time-series record at a specific location) have a Rayleigh distribution. For limited wave-induced vertical ship motions, these motions can be considered as Rayleigh-distributed. Such a distribution will allow the determination of average, significant, or extreme values. These extreme values have a low frequency of occurrence and should be associated in the channel depth design with the risk of bottom touching.

Critical Keel Points

Five or more critical points are located on the ship's keel at positions such as the bow, stern (rudder and/or propeller), port and starboard shoulder and quarter keels (Figure 2.10). Multiple points are evaluated so that the worst-case scenario is obtained regardless of how the different vertical ship motions combine due to phasing during the ship transit. Maximum motions will occur at different points for different wave and channel conditions.



Figure 2.10: Typical critical point locations on ships keel [Vantorre et al., 2008]

Response Amplitude Operators (RAO)

The Response Amplitude Operator (RAO) or vertical displacement transfer function is the ratio of vertical ship motion (i.e. output) to wave height (i.e. input) at a particular location on the ship. The frequency-domain RAOs are computed for the three vertical ship motions of heave, roll and pitch as a function of ship loading, speed and channel depth. The RAOs can be calculated as a function of wave frequency, encounter frequency, non-dimensional wavelength to ship length (i.e. λ/L_{pp}), or square root of λ/L_{pp} . The RAOs show where the resonance frequencies are strongest so that they can be avoided during normal ship operations. The RAOs for heave and pitch motions have similar shapes.

RAOs can be obtained by experimental means or numerical models. Experimental tests in a towing tank will usually give the most accurate RAO results, especially for more complicated vessel hull shapes and for wave spectra, but are relatively time-consuming and expensive. Numerical or theoretical methods are increasingly able to provide accurate predictions of wave-induced ship motions. For example, the 2-D strip theory or 3-D panel methods give accurate results. However, they require considerable detail of the design vessel geometry (i.e. ship lines) and must be calibrated using physical model or field data to validate their accuracy. In the case of small UKC, typically less than 30 % of the ship's draught (i.e. $h/T < 1.3$), there will be bottom damping of the vertical vessel motions due to the cushioning effect of the water under the keel. The 3-D numerical models have difficulty in computing ship motion response for very small UKC (say less than 10 % of the draught), since the dimensions of the panels representing the ship's hull have to be of the same order as the UKC. Therefore, small UKC would require a large number of panels on the ship's keel, which would add significantly to the required computation time. In these cases, physical models may provide results that are more accurate.

Significant Vertical Ship Motion at Critical Point j

Once the RAO is calculated for each of the three vertical motions ($i = 1, 2, 3$ for heave, roll and pitch, respectively), the spectral density of vertical response $Z_{i,j}(\omega, \theta)$ at each of the critical points j is computed by multiplying the square of the modulus of the RAO $|H_{i,j}(\omega, \theta)|^2$ by the directional wave spectrum $S(\omega_e, \theta)$ over encounter frequency ω_e and wave direction θ as:

$$Z_{i,j}(\omega_e, \theta) = |H_{i,j}(\omega_e, \theta)|^2 S(\omega_e, \theta) \quad i = 1, 2, 3 \quad (2-77)$$

The next step is to integrate these motion spectra $Z_{i,j}(\omega_e, \theta)$ to obtain the zero moments $m_{0i,j}$ or variances $\sigma_{i,j}^2$ at each critical point j as:

$$m_{0i,j} = \sigma_{i,j}^2 = \int_0^{2\pi} \int_0^\infty Z_{i,j}(\omega_e, \theta) d\omega d\theta \quad i = 1, 2, 3 \quad (2-78)$$

Then, the significant or characteristic peak-to-peak $Z_{i,j}$ or double amplitude (i.e. $A_{i,j} = Z_{i,j}/2$) of vertical motion is given as:

$$Z_{i,j} = Z_{m_{0i,j}} = 4\sqrt{m_{0i,j}} = 4\sqrt{\sigma_{i,j}^2} \quad i = 1, 2, 3 \quad (2-79)$$

The next step is to combine heave, pitch and roll RAOs to ensure proper phasing since the largest heave does not necessarily occur simultaneously with the largest roll and the largest pitch. A weighted average or combined RAO H_j of the individual heave, roll and pitch RAOs can be calculated. For instance, H_j can be obtained by multiplying the individual heave $H_{1,j}$, roll $H_{2,j}$ and pitch $H_{3,j}$, by their x-axis X_j and y-axis Y_j distances from the centre of gravity at each critical point j to ensure proper phasing relationships as:

$$H_j = H_{1,j} + H_{2,j} Y_j + H_{3,j} X_j \quad (2-80)$$

The combined H_j for these keel points can similarly be multiplied by the wave spectrum, integrated over frequency and direction and combined as above (Equations 2-71 to 2-73) to determine the total significant vertical ship motion amplitude $A_j = A_{m_{0j}}$ of each keel point j .

Figure 2.11 illustrates this procedure for the port quarter point and significant wave height $H_{m0} = 1$ m. The RAOs were derived from a numerical 3-D panel method for ship motions. The computed significant vertical motion amplitudes of the keel points are listed at the bottom of Figure 2.11, and will form the basis of assessing the extreme or maximum expected vertical motion of the keel of the vessel.

Expected Maximum Amplitude Motion

If the Rayleigh distribution of wave heights is accepted and if the vessel motions are small enough to accept a linear relationship between wave height and vertical ship motions, then the keel point motions will also be Rayleigh distributed and can then be computed for low probabilities of exceedance. The Rayleigh distribution for the computation of the expected maximum wave height of N_0 waves H_N (m) can be represented by:

$$H_N = H_{m0} F_R = H_{m0} \sqrt{\ln N_0 / 2} \quad (2-81)$$

where:

H_{m0} = significant wave height (m)

F_R = Rayleigh factor

N_0 = number of waves encountered during vessel transit = t / T_z

t = time duration of ship in channel (s)

Similarly, according to the discussion above for Rayleigh distributions, the expected maximum amplitude of vertical motions A_N is given by

$$Z_{Max,4} = Z_N = A_N = A_{m0} F_R = A_{m0} \sqrt{\ln N_0 / 2} \quad (2-82)$$

where A_{m0} is the largest significant vertical motion amplitude from all the critical points A_j for a particular wave event discussed in the previous section. The $Z_{Max,4}$ is then equal to A_N .

For example, if the significant wave height $H_{m0} = 2$ m, the zero-crossing wave period $T_z = 10$ s, and the ship is in the channel for a duration of $t = 20$ min (1,200 s); the expected maximum wave height that the ship will encounter is:

$$H_N = H_{m0} \sqrt{\frac{\ln N_0}{2}} = 2 \sqrt{\frac{\ln(120)}{2}} = 3.1 \text{ m} \quad (2-83)$$

where $N = 1,200/10 = 120$. This is the expected maximum wave height, but there is still the possibility that the actual maximum wave height will be higher (if the ensemble of maximum waves has its own probability distribution).

In the above example of Figure 2.11, and assuming an oscillation period for the vertical keel motions of $T_z = 14$ s (i.e. the spectral peak f_p is at the encounter frequency of $f_p = f_E = 0.07$ Hz), with the vessel being $t = 20$ min in the channel, the Rayleigh factor F_R of Eq. 2-81 is:

$$F_R = \sqrt{\frac{\ln N_0}{2}} = \sqrt{\frac{\ln(1200 / 14)}{2}} = 1.49 \quad (2-84)$$

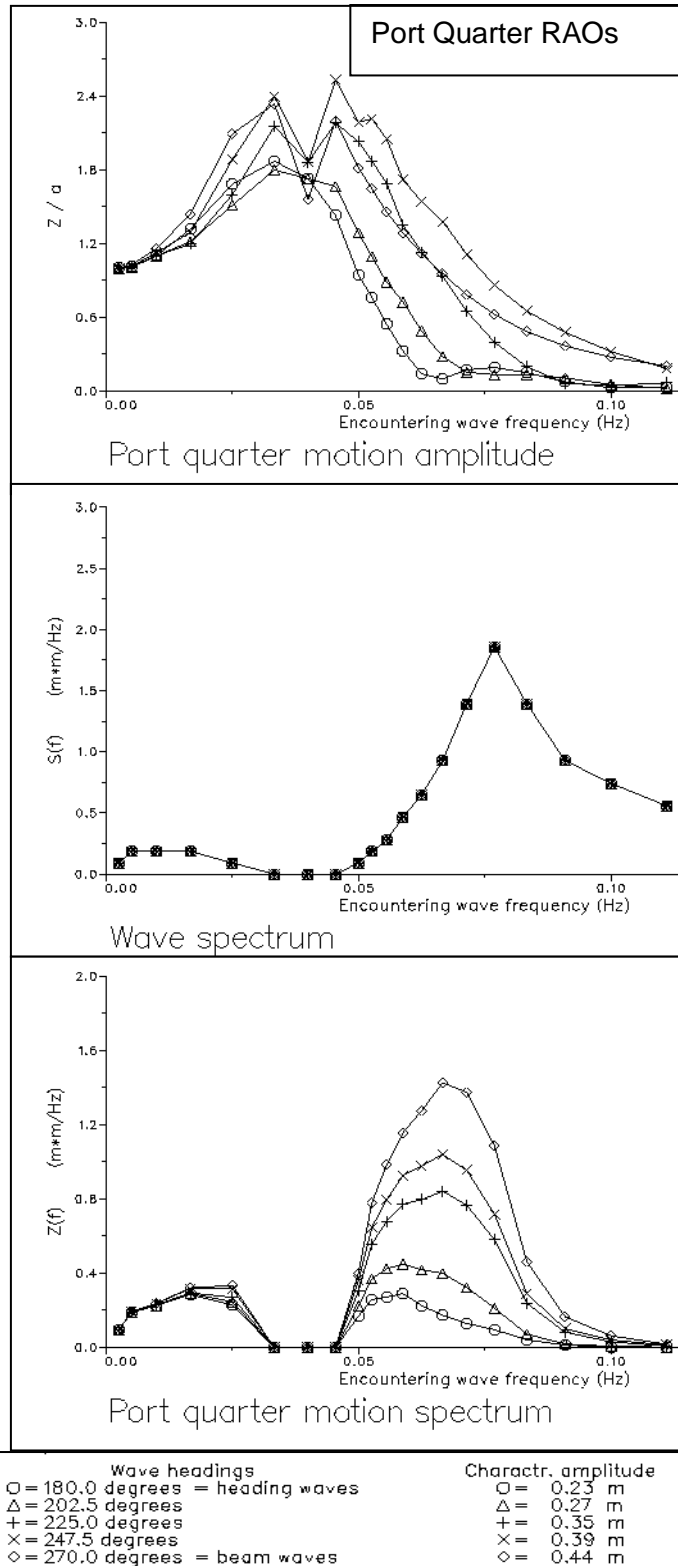

Figure 2.11: Port quartering RAO, wave spectrum, motion spectrum and significant (characteristic) vertical motion amplitude for heave, roll and pitch motions. This example is for $Hm_0 = 1$ m

The maximum expected vertical amplitude motion for beam seas at the port quarter keel Z_{Nj} is computed analogously to Eq. 2-82 as:

$$Z_{Max,4j} = Z_{Nj} = A_{Nj} = A_{m0} F_R = 0.44(1.49) = 0.66 \text{ m} \quad (2-85)$$

where j corresponds to the port-quarter keel location.

2.4.3 Bottom Factors

For the Detailed Design, four bottom factors are used. These include (a) allowance for bed level uncertainties, (b) allowance for bottom changes between dredging, (c) dredging execution tolerance and (d) muddy channel beds. Each of these is described in the sections below.

2.4.3.1 Allowance for Bed Level Uncertainties

The allowance for bed level uncertainties is site-specific and should be selected based on local knowledge. A minimum allowance for bed level uncertainty of at least 0.1 m is recommended.

2.4.3.2 Allowance for Bottom Changes between Dredging

The allowance for bottom changes between dredging is site-specific and should be selected based on local knowledge. A minimum allowance for bottom changes between dredging of 0.2 m, or 1 % of channel depth, is recommended.

2.4.3.3 Dredging Execution Tolerance

A typical dredging execution tolerance is 0.2 to 0.5 m, depending on bottom and dredger type.

2.4.3.4 Muddy Channel Beds

If muddy channel bed conditions exist, they should be incorporated in the design of deep-draught channels. Appendix E contains a thorough description of water depths in muddy areas including the nautical bottom approach. It presents information on mud characteristics, criteria for determining the nautical bottom, and behaviour of ships in muddy areas.

2.4.4 Air Draught and ADC

For Detailed Design of air draught H_{st} and ADC, please refer to Appendix F.

2.5 Probabilistic Design Considerations

The computation procedure for wave response allowance presented in Section 2.4.2.3 for the Detailed Design is an illustration of the computations related to a single transit of the design vessel in the channel. For each of such transits, a probability of bottom touching can be specified. For example, if a 1 % probability of bottom touching per event p is

accepted, the Rayleigh factor F_R can be computed for a 1:100 transit event, that is for a probability that is based on $100 \times N$ in Eq. 2-84. In this case, the F_R of the example in Section 2.4.2.3 would increase from 1.49 to 2.13 as:

$$F_R = \sqrt{\frac{\ln(N_0 / p)}{2}} = \sqrt{\frac{\ln[(t / T_z) / p]}{2}} = \sqrt{\frac{\ln[(1200 / 14) / 0.01]}{2}} = 2.13 \quad (2-86)$$

where $p = 0.01$. The expected maximum vertical ship motion Z_{Nj} for this keel point j would increase similarly from 0.66 given by Eq. 2-85 to 0.94 m as:

$$Z_{Max,4j} = Z_{Nj} = A_{Nj} = A_{m0} F_R = 0.44(2.13) = 0.94 \text{ m} \quad (2-87)$$

A different approach would be to define some low probability that during the lifetime of the channel (say 25 years), a ship should only touch the channel bed with resulting limited damage (i.e. not blocking the channel). In the case of the Europort Waterway at Rotterdam, this has been set to a 10 % probability of one such event occurring over a 25-year period [Savenije, 1996]. For such cases, the extension of the Rayleigh distribution may lead to very conservative results. A different probability distribution, the Poisson distribution, for such conditions has been suggested [Strating et al., 1982]. This will be discussed in Section 2.5.3.

It should be noted that a similar approach as outlined above for channel design, could also be used for operational management of deep-draught shipping in the channel. By specifying the acceptable maximum risk or probability of bottom touching of the vessel [Moes, 2008], an admittance policy can be formulated which is related to factors such as tide, wave conditions, ship speed and dangerous types of cargo. Such an admittance policy has been developed for the Europort Waterway and is called HARAP (HARbour APproach). In such a case, incoming ships can be guided to arrive at the time of channel admissibility for this particular ship, or departing ships can be loaded to their maximum draught in taking advantage of tide and moderate wave conditions.

2.5.1 Criteria for Probability of Exceedance

For channel design and operational allowance, the choice of the probability of exceedance P is important, as this relates directly to the shipping safety. One of the earliest summaries of safety criteria for deep-draught vessels in port entrance channels has been compiled by van de Kaa (1984). He lists various probability levels associated with ship manoeuvring incidents, such as collisions, strandings, accidents and ship-bed contact. Four of his listed probability criteria for ship-channel bed contact are:

- Accident per passage under average environmental conditions: 10^{-4}
- Accident with heavy damage per passage for average conditions: 2.5×10^{-7}
- Accident per passage under extreme environmental conditions: 10^{-2}
- Accident with heavy damage per passage for extreme conditions: 5.0×10^{-4}

PIANC (1997) has also listed probabilities of grounding. The results of an analysis of groundings in Northern European ports by Dand and Lyon (1993) showed grounding occurs with a probability of 0.03 incidents per 1,000 ship movements (a probability of 3×10^{-5} or one ship grounding per 33,000 ship movements). It should be realised these ship movements probably relate to all movements of larger-size ships under general environmental conditions. This probability value would, therefore, be between the above

criteria 1 and 2 of van de Kaa. The present practice at the Port of Rotterdam has been summarised by Savenije (1996), who quotes the two criteria presently in use at the port:

- During 25 years, the probability of a ship touching the channel bottom with maximum minor damage, must not be more than 10 %
- The probability that a vessel during its transit touches the channel bottom must always be less than 1 % for all weather conditions.

The factor of 10 % in Savenije's criterion #1 means that only one out of ten bottom touches during a period of about 250 years results in more than minor (i.e. serious) damage. It is accepted that (maximum) minor damage means that the ship is still manoeuvrable and would not block the navigation channel for other shipping traffic. This criterion is based on a shipping intensity of 250 deep-draught vessels calling at the Port of Rotterdam per year. This would mean that one bottom touch with zero to minor damage is accepted per 25 years, or per 6,250 deep-draught shipping events (i.e. transits). This is a probability of bottom touching of 1.6×10^{-4} per shipping event, which is the same order of magnitude as criterion 1 of van de Kaa, with a probability of 5×10^{-4} . The second criterion of Savenije, with the stipulation 'for all weather conditions', is the same as criterion 3 of van de Kaa.

2.5.2 Risk

It should be realised that risk is defined as the probability of occurrence multiplied by the financial and impact consequences. Therefore, in using the above probability criteria, one should optimise the risk, which includes the (financial and environmental) consequences of bottom touching. The consequence components of the risk are higher for (a) touching a rocky channel bed than a muddy bed, (b) tankers than for general cargo vessels and (c) sensitive environments than for industrialised areas. One should select risk criteria that are applicable to the local environment.

The choice of acceptable risk of grounding should be taken by the relevant Port Authority, considering all associated risks. This is usually related to an acceptable number of groundings during the lifetime of a channel. For example, if the shipping intensity would be on average four depth-limited ship passages per day during a 25-year period, this would mean one bottom touch per 36,500 depth-limited ship passages ship passages, or a bottom touch probability of 2.7×10^{-5} .

Table 2.9 provides an illustration of possible probability values (in terms of return periods) that could be used for the depth design of channels as a function of certain risk levels. The values in the table are the number of years where a single bottom touch by one of the vessels would be acceptable. In this way, responsible and affected persons can easily understand the level of risk that is associated with the design.

Based on the Rayleigh distribution, the vertical ship motion amplitude A_p for a probability of exceedance P_z is defined as:

$$A_p = A_{m0} \sqrt{\frac{-\ln P_z}{2}} \quad (2-88)$$

where A_{m0} was previously defined. The value of P_z is defined as:

$$P_z = \frac{1}{N_o N_p N_y} \quad (2-89)$$

where:

$N_o = t/T_Z$ = number of vertical ship motion oscillations or waves encountered during a passage in the channel

N_p = average number of passages per year

N_y = number of years or return period as shown in Table 2.9

Type of Channel	Channel Bed Condition		
	Hard	Medium	Soft
General Navigation Channel (Channel not in service of industrial facility or single specific terminal)	E1: 50	E1: 35	E1: 25
	E2: 250	E2: 150	E2: 100
	E3: 800	E3: 520	E3: 400
Specific Industrial Channel (Channel in service of industrial facility or single specific terminal)	E1: 35	E1: 25	E1: 15
	E2: 150	E2: 100	E2: 50
	E3: 500	E3: 350	E3: 250
Notes: 1. E1 = Low risk of loss of human life or environmental damages in the event of an accident 2. E2 = Medium risk of loss of human life or environmental damages in the event of an accident 3. E3 = High risk of loss of human life or environmental damages in the event of an accident			

Table 2.9: Return periods (Number of years N_y) as related to risk factors [Puertos del Estado, 1999]

2.5.3 Long-Term Probability Criterion

The probability P_{UKC} that the gross UKC will be exceeded during a defined number of ship passages under these design conditions can be computed from a Poisson distribution for the long-term occurrence of these events [Strating et al., 1982]:

$$P_{UKC} = 1 - \exp(-P_p N_p) \quad (2-90)$$

where:

$N_p = N_y Y_L$ = total number of ship passages

N_y = number of transits per year

Y_L = operational lifetime in years

P_p = probability of exceedance per passage.

If $P_p N_p < 0.01$, this relationship can be approximated by $P_{UKC} = P_p N_p$.

For example, during a 50-year operational lifetime of a channel, the design ship will make $N_p = N_y Y_L = 12 \times 50 = 600$ passages through the channel, with a probability of exceedance per passage of $P_p = 8.3 \times 10^{-4}$. The probability P_{UKC} according to Eq. 2-90 is then:

$$P_{UKC} = 1 - \exp(-P_p N_p) = 1 - \exp(-8.3 \times 10^{-4} \times 600) = 0.39 \quad (2-91)$$

Thus, the probability that during this 50-year period (for this particular case) the expected maximum value is reached or exceeded is 39 %.

As another example, a general design value for the exceedance P_{DL} during the lifetime of the channel of 10 % is being used for Europort/Rotterdam [Savenije, 1996]. In this case, Eq. 2-90 is rearranged to solve for $P_p N_p$ as:

$$P_p N_p = -\ln(1 - P_{UKC}) = -\ln(1 - 0.1) = 0.105 \quad (2-92)$$

If the total number of ship passages is assumed to be $N_p = 36,500$, it follows that $P_p = 2.88 \times 10^{-6}$ (or one bottom touch per $N = 1/P_p = 347,600$ ship passages). Therefore, from Eq. 2-82 it follows that the maximum expected vertical ship motion amplitude A_N is given as:

$$A_N = A_{mo} F_R = A_{mo} \sqrt{\ln N / 2} = A_{mo} \sqrt{\ln(347600) / 2} = 2.53 A_{mo} \quad (2-93)$$

As a final example, Briggs and Borgman (2003) presented a method for assessing the probability of a ship accident in an entrance channel for different recurrence intervals using three-dimensional physical model data for the C9 *President Lincoln* (2,900 TEU) container ship at Barbers Point Harbour, Oahu, Hawaii. Their method included a criteria for evaluating various channel configurations and depths for a range of realistic environmental (i.e. wind, wave and current) conditions and annual number of ship calls. This four-component climatology-interactive model included a Poisson probability law for number of ship arrivals, a Bernoulli probability law for grounding in a single random ship arrival, an estimation of the probability parameter in the Bernoulli law from model tests and a determination of recurrence intervals or random periods.

2.5.4 Probabilistic Design

In probabilistic design, the contribution of the various other probabilistic factors comprising the UKC (Figure 2.1) is not carried out by a direct addition of the expected extreme values. The probability of combined occurrence of the extremes, if considered as independent variables, is lower than the sum of the individual factors. Therefore, a direct addition would lead to an 'over-designed' channel depth. Bijker and Massie (1978) argue that, for a probabilistic approach of the design of the depth of port entrance channels, the instantaneous vertical ship motions should be used, as distinct from their oscillation range (which are represented by the Rayleigh distribution). The difference is that the instantaneous motion is measured at a fixed time interval from a reference datum (e.g. as with the 0.5 s standard sampling interval of a wave record for Fourier transformation), while the oscillation range is the single wave height of the oscillation (lowest trough to highest peak), which will be at different time intervals (wave periods). The instantaneous elevations of the wave-induced vertical ship motions can be expressed by a Normal or Gaussian distribution, with the variable expressed by the standard deviation.

If all probabilistic components, which contribute to the required UKC, are independent and have a Normal distribution, the combined distribution of these components can be expressed by the sum of their mean values and the square root of the sums of their individual standard deviations squared as:

$$\sigma_c = \sqrt{\sigma_s^2 + \sigma_b^2 + \sigma_w^2 + \dots} \quad (2-94)$$

where:

σ_c = combined standard deviation

σ_s = standard deviation of the motions of the design ship ($= \frac{1}{2} A_{mo}$)

σ_b = standard deviation of channel bed irregularities

σ_w = standard deviation of water levels

These computations can be executed for a number of channel sections, each with their specific wave climate, channel bed condition and water level variation. If a Normal or Gaussian distribution is accepted for the combined distribution of the variables, together with a UKC amplitude of, for example, $4\sigma_c$, this channel depth will then be associated with a probability of exceedance $P = 0.000032$ (or 1 minute out of 526 hours). This indicates the expected percentage of the passage time that the ship's keel will be at or below the channel bed. The proclaimed or nominal channel bed level should be chosen to be a sufficiently safe value, with a specified standard deviation and probability of exceedance.

The above computations can be repeated for a range of depths to determine the relationship between channel depth, ship draught and downtime. This is undertaken by schematising the range of tidal, wave and weather conditions into a set of discrete environmental conditions, each with a specific probability of occurrence. For each of these discrete conditions and ship draught, the percentage downtime can be calculated according to the above methods. These computed discrete downtimes are then multiplied by the associated probability of occurrence of the conditions to determine the overall downtime. This will also allow the computation of the channel downtime as a function of the channel depth and ship draught. The optimum channel depth can be determined by calculating the financial consequences of having to delay ship operations in the channel, together with the costs of deepening the channel.

2.5.4.1 Monte Carlo Simulation Technique

One of the methods to determine the probability of exceedance of the UKC by a ship could be a Monte Carlo simulation. In this approach, all factors and their individual probability distribution, as well as the probability distribution of deep-draught ships that call at the port, with random combinations, are used to generate a large number of navigation scenarios. The selection of relevant ship types for the Monte Carlo simulation is a subjective component of this approach. The simulated conditions should be limited to tidal-bound and channel-bound ships. Service or small vessels that would 'never' touch the channel boundaries should be excluded from the simulation, as these would unrealistically reduce the overall risk. For representative stable results, the number of conditions to be tested could easily be millions, but with fast computers, such a simulation could be carried out expediently. The number of conditions under which bottom touching occurs can then be determined as a percentage of the total number of simulations. This will then define the total probability of exceedance and the consequent risks of this choice of channel depth can be assessed. A note of caution is that samples from the distribution functions should not be taken in isolation and the independency of these functions needs to be verified.

2.5.4.2 Probabilistic Design Tools

The DUKC (Dynamic UnderKeel Clearance), CADET (Channel Analysis and Design Evaluation Tool) and UNDERKEEL are examples of existing probabilistic design tools that are presented in this section. Many laboratories and government agencies have equivalent probabilistic design tools for deep draught navigation in entrance channels. In the future, one can expect that these types of technology will become the norm rather

than the exception as channel design is optimised for safe, economical and efficient navigation. The designer needs to be careful in judging the input and evaluating the output of such models. The dynamics of the channel bed and the human element in causing events of risk should be carefully taken into consideration, preferably by experienced engineers. The final decision on the depth of the navigation channel should be determined using as many quantified and qualified risk factors as realistically possible, in addition to economic and environmental considerations.

Dynamic UKC Technology

The key to probabilistic design lies in the derivation and construction of accurate and representative probability distributions of the various UKC factors. Incorrect assumptions about independence of UKC factors or the shape of their distributions lead to errors in the assessment of the risk of bottom touches. One method of reducing the impact of these assumptions is by combining statistical and deterministic methodologies in the evaluation of an entrance channel design. An example of this type of probabilistic design tool is the DUKC technology [Atkinson and O'Brien, 2008 ; O'Brien et al., 2012]. The DUKC system deterministically assesses the UKC of a vessel with a known load condition and speed and track under specific met-ocean conditions. By simulating vessel movements over many years of use it is possible to assess the risk of bottom touching, waterway capacity and optimised depths through statistical analysis of the simulated UKC data.

Aside from the reduced need for accurate and representative probability distributions, the advantages of a combination of deterministic simulations with statistical analysis methodologies are:

- Allows the entrance channel design to be evaluated against one or more UKC (or other safe navigation) criteria simultaneously. The DUKC primarily evaluates UKC_{Net} and Manoeuvrability Margin as outlined in sections 2.1.2.7 and 2.1.2.8, but other criteria affecting safe navigation may be included. For example, one could select (a) minimum vessel separation distances or (b) maximum allowable wind and current speeds for safe vessel operations
- Allows the entrance channel design to be optimised to specific needs of its users. For example, rather than considering vessel sailings in isolation it is possible to optimise an entrance channel design to allow multiple deep draught sailings on a single tide. Not only does this permit the assessment of UKC safety, but also economic design aspects such as waterway capacity and throughput.

Channel Analysis and Design Evaluation Tool (CADET)

Another example of a probabilistic design tool is the CADET described by Briggs et al. (2006, 2012, 2013), Briggs and Henderson (2011), and Briggs et al. (2013). It predicts channel accessibility for acceptable levels of risk based on Gaussian and Rayleigh distributions and an Ochi extremal analysis of UKC from ship motion allowances for different wave, ship and channel combinations. Wave conditions are usually based on historical record of local waves through either hindcast or measured values. This historical record is composed of the persistence of joint distributions of wave height, period and direction on an annual basis. Accessibility is determined by calculating the risk of a ship impacting a project depth given the wave conditions in the channel. Deterministic methods might allow 100 % accessibility, but at a cost of additional dredging and an overly conservative channel design. The CADET predictions allow the designer to choose a channel depth with reduced accessibility for an acceptable level of risk.

CADET does not include the effects of heeling due to wind on ship UKC or channel width design elements. The interested user should refer to the references listed above for additional details of CADET.

Example CADET Application

CADET was applied to the modification of the entrance channel at Savannah, Georgia (USA). The goal of the Savannah Harbor Expansion Project (SHEP) was to evaluate three proposed channel options to accommodate next-generation post-Panamax (New Panamax) ships. The proposed Outer Channel is subject to waves and has a length of up to 37.5 km, width of 183 m, and maximum project or dredge depth of 14.9 m beneath the reference level of Mean Lower Low Water (MLLW). The project depth is restricted due to buried utilities, dredging costs, offshore reefs and environmental and political considerations. Each channel option consisted of six reaches, where a reach is required when changes in channel width, depth, or alignment occur.

The design ship was the *Susan Maersk* container ship with a capacity of 8,680 TEUs, $L_{pp} = 331.6$ m, $B = 42.8$ m and typical $V_k = 8$ to 14 knots. Two loading conditions with corresponding draughts were evaluated: light-loaded $T = 14.0$ m and fully-loaded $T = 14.5$ m. During right whale season, a maximum $V_k = 10$ knots is allowed in the Outer Channel to reduce the risk of collisions with a whale. Ship inputs included ship lines or hull offsets from the keel to deck-at-edge at 21 equally spaced stations between the forward and aft perpendiculars and bow and stern profiles. Additional inputs included longitudinal and vertical centre of gravity; roll damping factor; roll and pitch gyradii; wave frequencies for calculating response amplitude operators for heave, pitch, and roll; and critical point locations along the keel for evaluating UKC.

The US Army Corps of Engineers requires a minimum Gross UKC of 1.2 m. Because of environmental constraints on the maximum project depth, the tidal range up to 2.4 m is required to ensure safe navigation. Water depths in 30 cm increments were evaluated from a low tide value of 14.6 m up to a high tide value of 17.4 m MLLW (i.e. this range includes starting at existing depth, 2.4 m high tide maximum increase in depth and small increase at high end in case additional dredging is allowed). Of course, these tide heights only occur for limited durations and days each year so that the pilots will have limited sailing windows during any given day of a year.

Ninety-nine directional wave spectra were simulated using a TMA (Texel, Marsden and Arsløe) frequency spectrum and a \cos^n directional spreading function. The parameters for these spectra were obtained from a joint probability distribution of wave height and period that was obtained from a WIS (Wave Information Study) 20-year hindcast at the nearby WIS370 deepwater buoy. A coefficient of variation is used to account for uncertainty in the wave measurements or predictions. Also, the probabilities of occurrence for each wave are used in the CADET predictions. The spectral wave heights were reduced at each reach along the Savannah channel according to wave transformation study results.

Ship squat was included using the Beck-Newman-Tuck (BNT) algorithm that is incorporated in CADET. The BNT is based on the dynamics of a slender ship in a finite-width inner channel with an infinitely wide outside channel of shallow depth. Uncertainty in ship sinkage and trim is included in CADET. Additional comparisons of squat were made with Ankudinov and PIANC squat predictors. The BNT squat predictions were included in the CADET UKC analysis.

The CADET tidal analysis indicated that a depth of 15.2 m MLLW would be present for durations of 8 hours and a depth of 15.8 m MLLW for durations of 6 hours every day of every year. These durations are continuous time spans where the water level is at or

above the indicated threshold each day. Water depths of 16.1 m to 17.4 m MLLW would have continually decreasing durations from 4 hours (365 days per year) to 1 hour (7 days per year). Of course, the durations must be long enough to allow the ship to safely transit the Outer channel as well as the 31 km-long Inner Channel. For the Outer Channel, transit times range from 1 to 3 hours based on channel length and ship speed from 8 to 14 knots, so that the 6 to 8 hours durations should be sufficient.

CADET predicted days of accessibility for light- and fully-loaded ships, inbound and outbound transits, speeds of 6 to 14 knots and depths of 14.6 to 17.4 m MLLW. To account for uncertainty and risk, CADET includes a motion risk factor α and a channel reach risk level β in its predictions. Both of these risk factors are adjustable by the user. Values of $\alpha = 0.01$ and $\beta = 0.01$ were used in this application. The $\alpha = 0.01$ means that the ship has a 1 in 100 probability that the predicted motions allowance will be exceeded for the given set of wave conditions. The general rule is that if the probability of ship touching a flat channel bottom is less than 1 in 100 (i.e. this α) for each wave in a climatology during a given transit, then the channel is considered accessible for that depth. Similarly, the $\beta = 0.01$ represents the probability of one of the critical points on the ship (i.e. bow, stern, amidships) touching the project depth in a particular reach. It takes into account the uncertainties in depth measurements, dredge variability and over-dredge allowance. In general, the days of accessibility increase for slower ship speeds, outbound transits, interior reaches and light load conditions.

The days of accessibility assume the water depth is available 100 % of the time. When using tides, however, this is usually not the case as water levels have the limited durations discussed above. Therefore, the days of accessibility predicted by CADET were reduced by the relative percentage of the tide level. For example, a tide level occurring only 25 days per year is equivalent to only 6.8 % (i.e. 25/365). Thus, the CADET-predicted number of days of accessibility is multiplied by this tide level percentage to obtain the reduced days of accessibility when the tide level is occurring less than 365 days per year (i.e. every day of a year). Of course, this is somewhat simplistic and conservative as it assumes that the tide and waves are in phase, which could, but is not likely to occur simultaneously in a real-world situation. As a design tool, however, it is probably acceptable to interpret the results in this fashion as it makes the comparisons uniform. During actual transits, the pilots would need to take the wave and tide conditions into account to ensure safe navigation during the entire transit.

The light-loaded ship is the most realistic ship expected to use the Savannah Channel as full design-draught ships rarely occur at this location. For the light-loaded ship, a minimum depth of 15.2 m will have 358 days of accessibility per year with 8-hour durations during inbound transits at 10 knots. Since this tidally-adjusted depth is available for durations up to 8 hours every day of the year, it is not necessary to reduce the CADET days of accessibility by the tide level percentage. However, if a longer duration is required, then the days of accessibility would be reduced by the tidal percentage of the desired duration since it decreases from 9 hours for 331 days (i.e. 331/365 = 90 %) to 12 hours for only 64 days (i.e. 64/365 = 17 %). Also, increased ship speed requiring deeper draughts can be accommodated if willing to accept decreasing durations of 8 hours or less as the tide level increases. For instance, at this 15.2 m depth, an 8-hour duration is possible for 338 days per year during inbound transits at 14 knots. Finally, if a larger depth is required for any ship speed, the duration will decrease along with the days per year since the tide level will not be available year round. The CADET predicted days of accessibility will be decreased by multiplying by the tidal percentage for the desired depth.

For the fully-loaded ship at a minimum depth of 15.8 m, durations up to 6 hours are available for 360 days per year during inbound transits at 10 knots. A longer duration of 8 hours is possible, but only for a reduced days of accessibility of 24 days per year (i.e. $360 \times 25 / 365$) since the tide is only available 25 days per year for this water depth and duration. Increased ship speed is possible at this depth for durations of 6 hours or less for 357 days per year for inbound transits at 14 knots. As before, deeper channel depths are also attainable, but result in shorter durations and reduced days of accessibility. For a ship moving at 14 knots, a channel depth of 16.1 m is possible to achieve with durations up to 4 hours for 362 days per year. A longer duration up to 6 hours of increased water depth is available, but results in reduced days of accessibility of 143 days per year. This is due to the tide level being at that height for 6 hours only 144 days per year (i.e. $362 \times 144 / 365$).

CADET uses wave-induced ship motions due to heave, pitch and roll in the prediction of days of accessibility. These motions are output for each ship loading condition, channel reach, water depth, wave condition, transit direction, ship speed and critical point. The 99 wave conditions represent the entire range of exposure over a 20-year design life. Extreme wave conditions produce the largest vertical motions, but also have very small probabilities of occurrence. The user can examine individual, average, typical, extreme, or specialised ranges of wave conditions. One specialised range includes only the highest 3 % to 5 % of waves since it gives a more realistic view of design wave conditions during transits. Ships would not be affected by routine smaller waves and would not use the channels during extreme storm events. Thus, only the larger waves that would have a significant effect on the ship are retained in the analysis, although they would have very low probabilities of occurrence.

As a comparison with the Concept Design (CD) recommendations, the Savannah Channel could not be used for such large ships if a purely deterministic requirement was enforced. The user can refer to Appendix C to observe that the *Susan Maersk* dimensions correspond well with Table C-1. According to the CD recommendations in Table 2.2, a Gross UKC (including squat, wave response, and MM) of at least 2.1 m is required for the Outer Channel (i.e. 15 % of T). Therefore, a water depth up to 16.1 m MLLW for the light-loaded ship and 16.6 m MLLW for the fully-loaded ship is required according to the CD procedure. Although the CD predictions are reasonably close to the CADET required depth, including tide elevation, of 15.2 m MLLW for the light-loaded ship and 15.8 m MLLW for the fully-loaded ship, the CD predictions are overly conservative. Thus, by using the CADET probabilistic predictions, the port does not have to dredge the channel as deep as the CD procedure would require. This represents a large saving in dredging costs, especially in this case of a long access channel, compared to probably minor delay costs of shipping.

In summary, both ship loading conditions can be accommodated using the available tide depending on ship speed, desired UKC, and water level duration. Transits with the deeper draught ships will require tidal assistance at all times for safety. Since the tidal water levels only occur for a fraction of any day, there may be some instances where ships will need to wait on the tides to ensure safe navigation. However, since these large ships will not be calling on the port very frequently, this should not be a problem for efficient use of the channel. The interested reader should refer to the report by Briggs and Henderson (2011) for additional technical details. For more detail on the analysis of the economic aspects of deep-draught channel optimization, the reader is referred to the report of the US National Economic Development group of USACE and IWR: 'Manual for Deep Draught Navigation', IWR Report 10-R-4, April 2010.

UNDERKEEL

The UNDERKEEL computational model has been developed for the study of ship motions and wave forces on ships, specifically in shallow water. It employs the standard linearised wave theory with potential flow applied in the frequency domain (i.e. regular waves) to represent the behaviour of waves and water flows in the vicinity of the ship. This is implemented in conjunction with a strip or slender body theory treatment of boundary conditions at the hull adapted to allow accurately for flows underneath the keel. All six components of the vessel's motion are computed and all components of wave force and moment. The model has been verified by comparing computed values against field measurements and measurements of the movements of physical model vessels. A typical application is the estimation of vertical motions of ships underway in a navigation channel in order to estimate the likely minimum dredged depth needed for safe transit in waves

Although the model operates in the frequency domain, superposition principles can be applied. UNDERKEEL can thus be used to compute motions of a vessel or wave-induced forces acting the vessel for any given required random wave input, including short-crested (multi-directional) sea conditions. This is for both first and second-order effects and so it reproduces the full range of wave, wave-induced flow and wave force phenomena.

Second-order forces are those due to:

- Surface stress
- The Bernoulli pressure effect
- Force rotation
- Pressure displacement
- Second-order wave diffraction effects
- Set-down and associated diffracted wave fields

These force effects are proportional to wave height squared and although often small in magnitude compared to first order waves, they are important because the horizontal motions of a large ship may be dominated by low frequency components.

A particular feature is that UNDERKEEL computes forces due to set-down bound waves (which are known to be the dominant forcing effect in many shallow water cases) without resorting to an approximate treatment of wave diffraction.

2.5.5 Operational Channel Allowance

The use of an existing channel can be optimised for each particular ship passage by using similar computations as used for the channel design. To determine the probability that the vessel exceeds an available UKC_{Net} , which is based on the ship's vertical oscillations rather than on the instantaneous variation in UKC, the Rayleigh distribution as represented in Eq. 2-88, could be used. If the UKC is chosen to be equal to a specific value of A_p , the probability of exceedance p of UKC can be computed by the inverse of Eq. 2-88. For example, for $A_p/A_{mo} = UKC/A_{mo} = 2$ it follows that:

$$p = \exp\{-2(UKC / A_{mo})^2\} = \exp\{-2(2)^2\} = 3.35 \times 10^{-4} \quad (2-95)$$

This means that during the passage of the ship at this particular UKC, the probability for the UKC limit to be exceeded will statistically be during 1 in 2,981 (i.e. $1/p$) ship oscillations. The percentage of time when a ship cannot be safely allowed into the

channel for this ratio of UKC/A_{mo} as an accepted level of safety (i.e. when the computed $A_p > UKC$) is called the channel downtime for this class of ship.

2.5.6 Tidal Window Design

Vantorre et al (2008) developed a risk-based criterion for predicting tidal windows in Flemish channels for deep-draught ships. Their *ProToel* tool calculates the probability of touching bottom during transit so that the tidal window can be determined. Input data includes ship characteristics, speed, tide, directional wave spectra, bathymetry, trajectory and departure times. A database of RAOs for a range of ship types and loading conditions was generated based on physical model experiments and numerical model simulations. Other considerations include penetration into muddy bottoms and cross-currents. Although the probabilistic aspects are presently based on the ship response to waves, future enhancements will include uncertainties for ship draught, bottom level fluctuations, tidal prediction errors and wave forecasts.

3 CHANNEL WIDTH, HARBOUR ENTRANCES, MANOEUVRING AND ANCHORAGE AREAS

The layout of a port is to a large extent determined by its water area. This includes the orientation and alignment of the approach channel, the manoeuvring areas within breakwaters (if these are needed), turning circle and port basins for the actual berths. These dimensions are of great importance: first because they constitute a major part of the overall investment and second because they are difficult to modify once the port has been built.

The design aspects are mostly centred on the ship: its manoeuvring behaviour under influence of wind, currents and waves, its vertical motions in waves and the horizontal and vertical motions at berth. It is therefore necessary to understand the manoeuvring behaviour and hydrodynamic responses of the ship. Another aspect to be taken into account is sediment transport, in terms of the effect of the port layout on the natural process, and hence on the coast, how siltation can be minimised/managed inside the port and approach channel. Finally, environmental and safety aspects also play a role in the layout design. A major issue in the expansion/deepening of existing ports and channels is the removal and deposition of dredged material. Often this is polluted to some degree and (international) rules prevent disposal at sea [PIANC, 1996]. In many countries environmental regulations require mitigation and compensation measures be taken when port (or other) development affects existing ecological systems. Safety considerations lead in some cases to additional requirements.

In very busy ports the approach channel develops into a system of dredged channels for the largest ships (channel bound traffic) and channels marked by buoys. Both are available for inbound and outbound traffic (and in open sea may be separated by traffic separation zones).

Methods used for determining the horizontal dimensions of channels, and in particular their widths are:

- Empirical methods
- Fast-time navigation simulation models
- Real-time navigation simulation models
- Physical model investigations

The methodology with respect to the horizontal dimensions used in this chapter is a two stage process consisting of:

- Concept Design (3.1), where empirically based methods are used
- Detailed Design (3.2)

The concept design methodology is based on the initial premise of a Design Ship, specified to represent the most representative ship expected to use the channel. In some cases, more than one Design Ship may be specified (see Chapter 1).

In the Concept Design stage, initial estimates of the overall physical parameters of the proposed channel, in terms of the width, depth and alignment, are determined from physical environment data and other information available at the outset of the design process. The Concept Design process is intended to be rapid in execution and not to require excessive input data, so alternative options can be evaluated quickly. The output

physical dimensions will be combined with proposals or assumptions on operational limits and Aids to Navigation (AtoN). As a consequence, and necessarily, the Concept Design will provide a relatively conservative estimate of the required width, which may be optimised, as appropriate, using Detailed Design techniques.

Detailed design is a more elaborate process and may utilize physical/mathematical and/or simulation models to provide detail on aspects such as ship manoeuvring, traffic flow and risk analysis. Detailed design also involves investigations, such as marine risk analyses in relation to traffic intensities, traffic rules and channel capacity and in most countries, environmental impact as marine impact assessment studies are required.

The results of the concept design stage will be satisfactory for preliminary design of most channels, but occasions will arise when this approach is not sufficient to confirm or differentiate design options, in which case more elaborate methods will have to be applied.

3.1 Concept Design – Horizontal Dimensions

For horizontal dimensioning, this report gives procedures and steps to be followed with some examples.

The width of a navigation channel is becoming increasingly important, essentially due to the increase in ship beam to improve cargo carrying capacity as vessel draught remains restricted. At the same time, the windage of some large carriers is increasing considerably (especially for car carriers and container vessels, but also for other ships such as, for instance, LNG carriers) and the effect of waves and currents is particularly important for outer channels. In addition, ship-ship interaction in passing or overtaking must be considered for two-way channels. Also, bank effects depend strongly on the speed of ships and distance to and type of the bank, so should also be considered during this stage of design.

Positive developments regarding horizontal dimensions and reduction of the risk of accidents are the improvement in Aids to Navigation (AtoN), especially electronic charts, differential global positioning systems (DGPS) and Vessel Traffic Services (VTS) and Automatic Identification Systems (AIS). All these technologies provide enhanced knowledge of vessel location, early drift detection, nearby traffic and fairway environment.

Finally, it is important to stress the necessity to analyse future changes in vessel dimensions and navigation technologies during the design of channel width, because experience shows that many vessels transiting channels are frequently much larger than those for which the channels were originally designed.

3.1.1 Channel Width

The channel is part of the fairway (usually dredged) to allow passage of deep draught vessels as indicated in Figure 3.1 and Figure 3.2. In many dedicated channels the AtoN will be close to the edge of the channel to indicate the limits of safe navigation, but on those with a range of traffic, the fairway markers may be positioned to allow the passage of smaller vessels on either side of the dredged channel. In other cases, both the deep water channel and the outer lanes for smaller vessels may be marked.

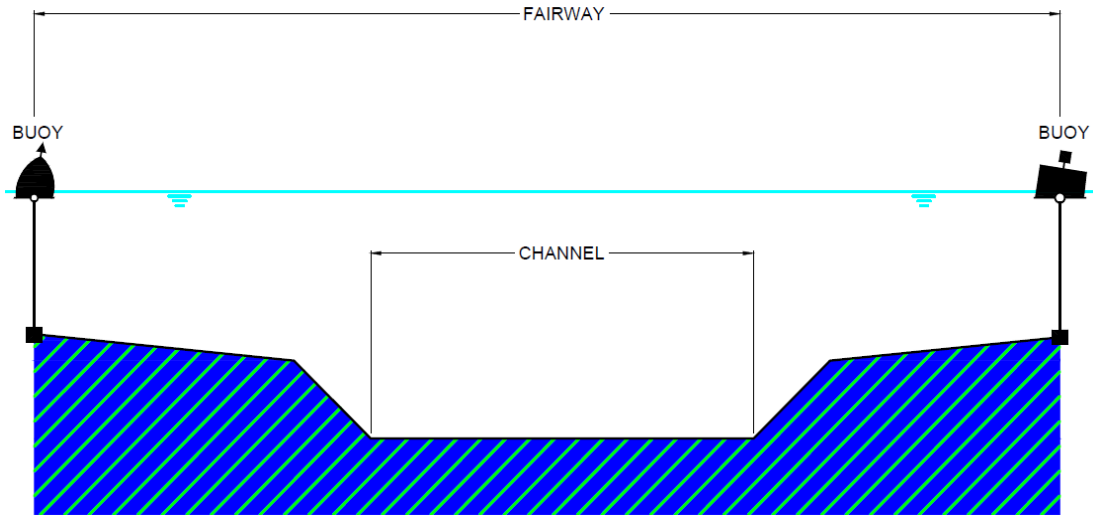

Figure 3.1: Channel and fairway definition
(where channel is defined by the channel bed width or width at nominal bed level)

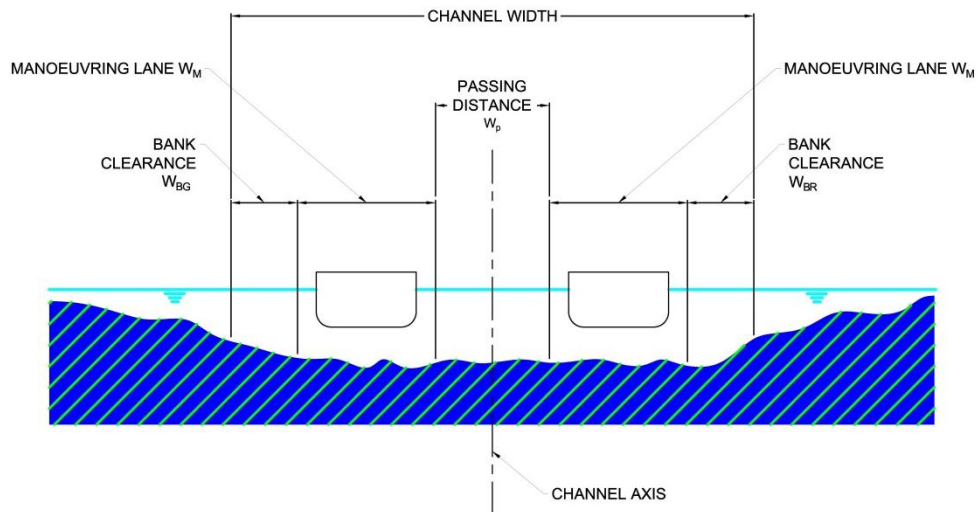

Figure 3.2: Elements of channel width

3.1.1.1 Introduction to the Concept Design Method

The key parameters of alignment, width and depth are all interlinked. Additional width can compensate for reduced depth and alignment can be changed to allow for reduced width or depth. However, with some exceptions the link is not strong and, at the Concept Design stage, some aspects of width and alignment can, to a certain extent, be decoupled from those of depth.

In this report, an overview of the different aspects in the design of horizontal dimensions of the approach channel is presented in Sections 3.1.2 to 3.1.7. In Section 3.1.7 an introduction to Spanish and Japanese design standards for channel design in those countries is also given.

3.1.2 Channel Alignment and Width Consideration

3.1.2.1 General

Channel alignment should be assessed with regard to:

- Shortest channel length
- Conditions/basins, etc. at either end of the channel
- Need to avoid obstacles or areas of accretion which are difficult or expensive to remove or require excessive (and hence costly) maintenance dredging
- Prevailing winds, currents and waves
- Avoiding bends, especially close to port entrances
- Environment on either side of the channel, such that ships passing along it do not cause disturbance or damage

Straight channel sections are preferable to curved ones and the designer should strive for an alignment consisting of a series of straight sections connected by smooth bends, where necessary, without abrupt angles (see Figure 3.3). Individual sections may have different widths and depths and be navigated at different speeds.

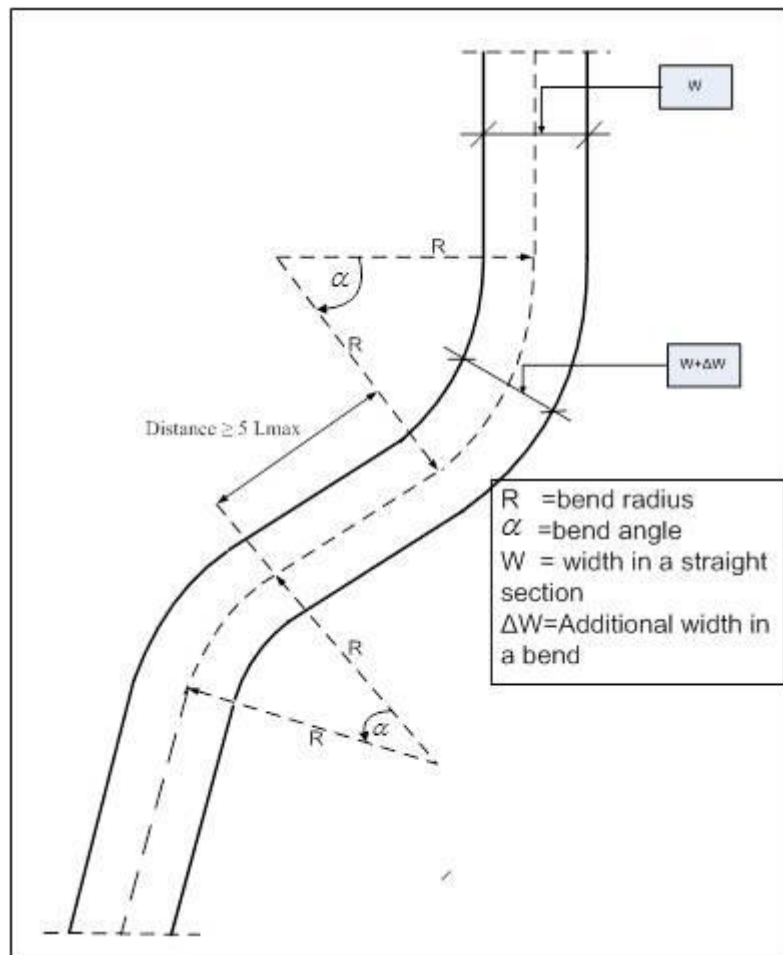

Figure 3.3: Bend configuration

It is preferable to have the prevailing currents aligned with the channel to minimise cross-currents. The same applies to wind and waves, although these may come from any direction. Usually, the prevailing wind and wave directions are used in design to judge

whether the likely access downtime due to strong winds or high waves from other directions is acceptable.

It is also advisable that the channel be aligned such that the ship *is not* heading directly at the quay or jetty during its approach. Any channel whose direction is perpendicular to the berthing face should be aligned to one side of the quay or jetty, so the ship must turn (or be swung) to arrive at its berth. This minimises the risk of ships contacting the jetty or quay in the event of losing control during the approach.

3.1.2.2 Bend Configuration

A bend will normally join two straight channel sections. However, two bends could also occur sequentially, although such features should be avoided, where possible.

In some cases concatenated bends will be unavoidable and manoeuvring simulation provides the only technique to determine the adequacy of their design. Of particular importance will be the positioning of the vessel in the first bend. This must be correct (usually with little margin for error) if the succeeding bend(s) are to be navigated successfully. If possible, the distance between successive bends should be greater than five ship lengths of the largest design ship (see Figure 3.3). Transitions shorter than this length should be investigated in a manoeuvring simulation study. If two bends turn in the same direction the distance between the two bends should be greater than 3 ship lengths of the largest design ship.

A bend may or may not have banks. Where banks are present the channel may be almost like a canal at low water, and where they are not present, it may simply indicate a turning manoeuvre from one channel section to another. Ship behaviour and, as a result, bend marking, will differ for each type. The bend with banks could cause the ship to change its behaviour due to bank effects so their presence will need to be indicated.

Bend radius and bend angle should initially have been chosen in the concept design stage following the suggestions made in Section 3.1.6. Simulator based studies can be used to determine if the particular configuration is suitable or can be optimised. It will soon become apparent if the ship handler is comfortable when navigating a bend as the problems of too long a bend at too great a radius will be manifest in disorientation and excessive use of the rudder. The problems of too small a bend radius may result in the ship crossing the channel boundary and, in such a situation, it may be necessary to explore the use of tugs to aid the ship if the radius cannot be increased and the ship speed is low enough.

3.1.2.3 Basic Manoeuvrability

The dynamics of ships are such that, when under manual control (as is usually the case in approach channels) they will follow a swept path, which, in the absence of any external forces from wind, waves, current, etc., will exceed their breadth by some amount (Figure 3.4).

This is due to the speed of response of both the ship-handler in interpreting the visual cues indicating the ship's position in the channel, and that of the ship in reacting to the rudder and main engine. The width of the swept path, which is the basic manoeuvring lane, will depend on a number of factors, but the key elements are:

- the inherent manoeuvrability of the ship (which will vary from ship to ship and with water depth/draught ratio)

- Ability of the ship-handler
- Visual cues available to the ship-handler
- Overall visibility

Of these, the first two are the most important since the other two can be dealt with by suitable AtoN both outside (e.g. buoys) and onboard the ship (e.g. radar) (see Chapter 4).

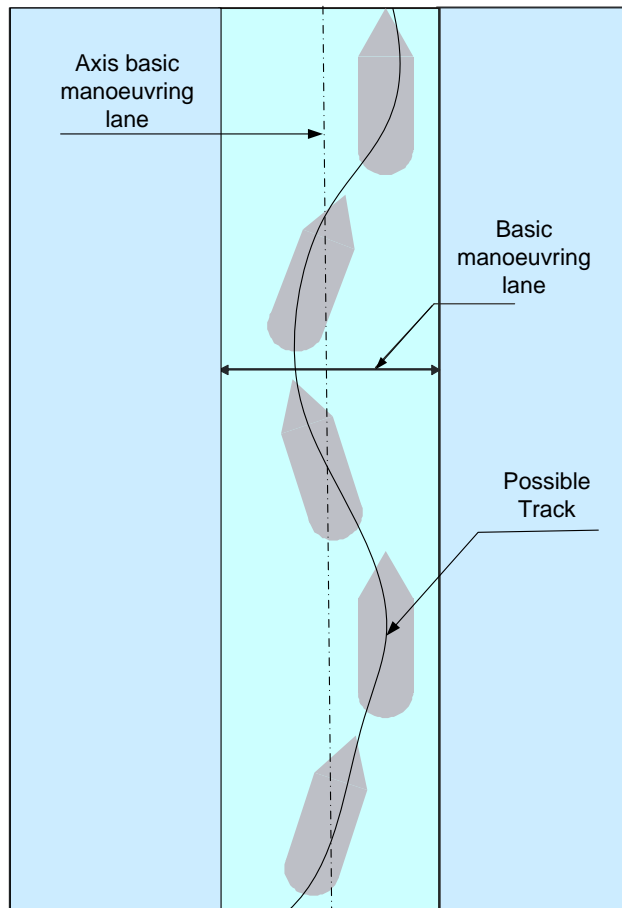

Figure 3.4: Basic manoeuvring lane

The ship manoeuvrability basically consists of the following three characteristics:

- a) course keeping ability with low rudder angles $\delta_R < 5$ deg
- b) course changing ability with medium rudder angles $\delta_R = 10$ to 20 deg
- c) turning ability with a hard-over rudder

Among these characteristics, the course keeping ability is the most important for channel width design. Full bodied ships (such as VLCCs and large bulk carriers) with high block coefficients may be inherently course-unstable showing some increased drift during steady turning, while fine-form ships (such as container ships and LNG carriers) with low block coefficients are more course-stable. Regarding shallow water effects, ship course stability generally increases as the water depth decreases from deep water conditions. However, it should be noted that fully laden ships sometimes show more course-unstable features in medium water depths of $h/T \approx 1.5$ (where h is water depth and T is ship draught) than in deep water. In shallow water of $h/T = 1.2$ or lower, as in many harbour

areas, the course keeping ability of ships is largely improved, but the turning ability is decreased.

The ship handling characteristics in a channel and the deviation from its course may primarily depend on the skill of the ship-handler. Navigation aids together with overall visibility greatly influence ship handling. The following three types of on-board navigation equipment are among those currently available in ship handling operations: a light buoy observation by the mariner's naked eye, a light buoy observation by RADAR and the direct use of GPS or differential GPS (DGPS).

In the course keeping operation (under manual control or active auto pilot) in the channel, the ship will have some amount of drift (lateral deviation) from its course caused by unsteady turbulence effects, even if in calm water. Due to this drift, the ship has a 'snaking' trajectory in the channel. The magnitude of drift depends on both the inherent manoeuvrability and the ship handling. The ship drift may be hard to detect for a small amount of deviation, although an auto-pilot may detect it. However, the ship-handler can recognize the drift when the lateral deviation from the channel centre line becomes considerable. This detectable drift ("snaking" amplitude) should be the primary design consideration for the determination of channel width as the basic manoeuvring lane. With skilled monitoring of a ship's passage, it is possible to monitor lateral drift from a planned course to within a beam width of the ship, depending on the beam of the ship.

3.1.2.4 Environmental Forces

The channel should have sufficient width to ensure safe navigation allowing for the effects of external forces due to cross winds, currents and waves.

Cross Wind

Cross winds will affect the ship at all speeds (Figure 3.5), but will have its greatest effect at low ship speeds. It will cause the ship to drift sideways or to take an angle of leeway, both of which increase the width required for manoeuvring. It is unlikely that a ship will be able to maintain a steady course at low speeds in a cross wind; the ship-handler will have to steer the ship slightly into the wind, resulting in the ship developing a drift angle and a slightly oscillatory course.

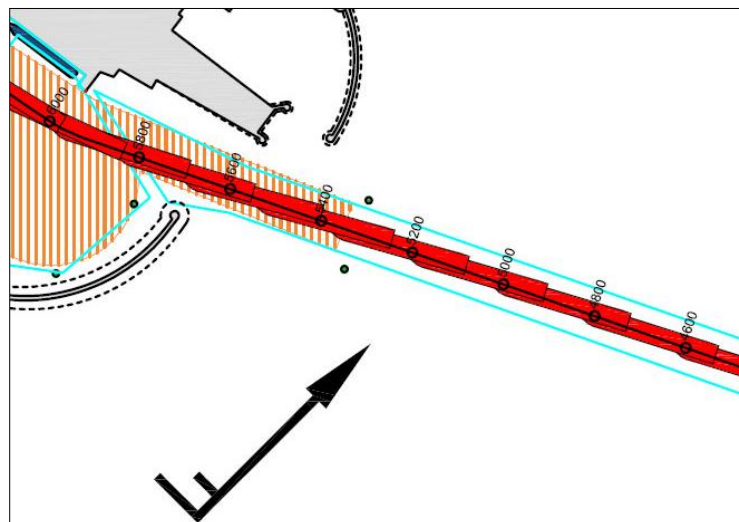

Figure 3.5: Ship course under strong wind conditions

Cross wind effects depend on:

- Ship speed
- Windage of the vessel (relative to lateral submerged area)
- Depth/draught ratio (because a ship's resistance to lateral motion increases as the depth/draught ratio approaches unity since wind causes less drift at small underkeel clearances)
- Wind speed and direction relative to the ship

Some width allowance, over and above that needed for basic manoeuvring, must therefore be made for wind effects. Information on wind speeds and directions for the area under consideration is needed.

Wind effects become significantly larger at low ship speeds, such as in harbour areas, and even at high ship speeds for high-sided vessels.

To keep a straight course in the channel under cross winds, counter helm is required to generate a suitable drift angle to compensate for leeway. These features are due to the balance of hydrodynamic forces (hull forces and rudder forces) and aerodynamic forces acting on the ship. The channel width requirement for cross winds is estimated by taking this obliquely running condition into account.

Currents

Cross-currents affect a ship's ability to maintain a course, while longitudinal currents affect its ability to manoeuvre and stop. As previously mentioned, the manoeuvrability of a ship changes as its depth/draught ratio approaches unity. As a result, its ability to cope with currents will also change as the water depth becomes shallower.

In some ports, currents may be too strong at certain stages of the tide to allow some ships to navigate safely. This may cause their arrivals and sailings to be restricted to certain time periods (or 'tidal windows') in the tidal cycle. This implies that there will be times (access downtime) for which the channel will not be available for such ships. The acceptability of downtime is dependent on safety and economic criteria.

Cross-currents affect the course keeping motion similar to cross winds. However, in order to keep a straight course under cross-currents, the ship should be operated to run obliquely to the current, with the rudder amidships, to compensate for the current velocity perpendicular to the ship's desired course (i.e. the line of the channel). For this reason, the ship speed and current speed perpendicular to the ship's desired course are key parameters in channel width design. Note that the current may change direction and strength considerably over a relatively short distance and time interval during the tidal cycle. Also, when approaching breakwaters or jetties, high current gradients may influence the course of a ship.

Waves

Waves will naturally influence the channel depth design as a result of the ship's vertical motions (pitching, heaving and rolling). However, they may also have effects on the width design. The ship generally makes a yawing motion in waves due to unsteady wave forces. Therefore, the channel width should include the drift due to such yawing. In addition to unsteady wave forces, there are steady 2nd-order wave drift forces, which are similar to wind forces. In following waves, course instability may occur (which may result in broaching) in the case of long waves and relatively small vessels. These wave drift forces may be considered depending on the local wave conditions.

3.1.2.5 Visibility

Restricted visibility (which is generally regarded as less than about 0.5 nm) will have a direct impact on the size, type and density of traffic permitted to operate. For example, traffic may be regulated to one-way, the movement of dangerous cargo vessels may be prohibited, or the movement of usually non-piloted vessels may require the services of a pilot. If visibility deteriorates to an extreme level, it is possible that the safety of the tugs may be compromised and thus the movement of large vessels within the area may be reduced or prohibited. If periods of poor visibility occur frequently, the spacing between channel marks should be reduced accordingly.

3.1.2.6 Bank Clearance and Ship-Ship Interactions

Bank Clearance

When a ship navigates in the vicinity of a channel edge, flow around the ship's hull varies and becomes laterally asymmetrical with respect to its longitudinal centre line. This generates hydrodynamic forces due to the asymmetrical flow. To avoid uncontrollable situations in a channel with underwater banks, additional width outside the manoeuvring lane is required (see Figure 3.6).

Important factors are:

- Ship speed
- Bank slope or bank structures
- Cross-section/symmetry of the channel
- Under keel clearance (ratio h/T)
- Distance between the ship and bank

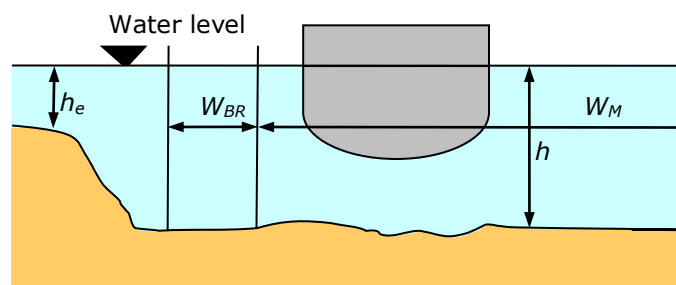

SLOPING CHANNEL EDGES AND SHOALS

Figure 3.6: Bank clearance

Ship-Ship Interaction

Similar dynamic interaction forces due to asymmetrical flow also act on two ships when they are transiting close to each other. The ship-ship interaction should be considered both for meeting (ships travelling in opposite directions) and overtaking manoeuvres. The additional width requirement to take account of ship-ship interaction also depends on the traffic density in the two lanes, as the greater the density, the greater the width that is required. To reduce the effects of these interaction forces to an acceptable minimum and ensure navigation safety, an additional channel width W_p should be included outside (centred about the channel axis) both basic manoeuvring lanes W_{BM} (see Figure 3.2). The magnitude of the necessary counter rudder to overcome interaction forces is one of the key parameters in the additional width design.

3.1.2.7 Fairway Marking and Positioning Systems

Fairway Marking

Pairs of buoys should be arranged on either side of the fairway to indicate the manoeuvrable zone. In general, light buoys or beacons are placed to enable night navigation. The clearance between two buoys in the direction perpendicular to the ship's course should be determined with consideration of the design ships, their transiting speed and the visibility (such as the frequency of fog occurrence). Fairway markings should also be placed in the region of a bend and leading lights/lines and other guide marking may be required in a fairway with successive bends.

Positioning Systems

Ship positioning systems, such as GPS or DGPS with electronic charts are widely utilised nowadays in ship handling operations. However, although electronic charts are increasingly found on board ships, some may not be official ECDIS but ENC's and, therefore, come with a warning that they must not be used for navigation. Ship-handlers judge and recognise the ship's position by an image of GPS information on the display of the electronic chart. However, there are two kinds of errors that can occur with respect to GPS utilisation. One is the perception error on the electronic chart display, where the image information on the electronic chart is definitely presupposed to be sufficiently accurate, but positioning of the ship is made solely by perceiving ship movement on the display by the naked eye. For this reason, some perception error (a half of a ship's beam or so) should be taken into account in the design of the manoeuvring lane. The other is the error of GPS information itself, for which an error of at least 3 m may be assumed, subject to future developments in GPS systems. Due to the improved accuracy of DGPS, no error needs be considered for ship positioning, although there are errors to be considered, such as the accuracy of the antenna installation and calibration. Note that GPS is not the only method for determining ship position.

3.1.3 Outer Exposed Channel and Inner Protected Channel

A distinction can be made between outer and inner channels. The outer channel is generally located further offshore from the inner channel and may be exposed to wave action that can produce significant vessel motions of heave, pitch and roll. These affect the requirements for underkeel clearance (UKC). The inner channel is usually located in a more or less protected area inland of the outer channel and is generally sheltered from wave action. Special attention should be paid to the transition between the outer and inner channel sections. In this area the ship may pass through a harbour entrance into the protection of breakwaters or jetties. In this transition area strong current gradients may occur. As a result the drift angle of vessels has a tendency to increase initially, if the bow of the vessel is in more or less still water, while the stern is still experiencing cross-currents, which can cause introduce a turning moment on the ship. This condition leads to additional width requirements.

3.1.4 One- or Two-Way Channels

To decide whether a one- or two-way approach channel is required, the capacity of the approach channel, in terms of ships that can be handled per year with an adequate service level, should be estimated.

Normally, the first choice for an approach channel is a one-way channel using the design ship with the maximum beam and windage (see 1.4.2.1). This is usually the most economical design for shorter channels with low traffic intensities. However, for longer

channels and/or higher traffic intensity, two-way channels may provide a better design. In some cases, a compromise can be created by constructing sidings or passing places along the channel that can ensure safe navigation in combination with VTS regulations. For instance, the Kiel Canal between the North Sea, Baltic Sea via the River Elbe. It has an average trapezoidal profile with a bottom width of 90 m, waterline width of 162 m and depth of 11 m. There are 12 sidings along the nearly 100 km-long canal to allow safe passage of larger ships. Two design ships were used in the design: $L_{oa}/B/T = 235/32.5/7$ m and $L_{oa}/B/T = 175/26/9.5$ m. The Canal is only one-way for these large ships, but two-way for smaller ships.

The capacity of the channel(s) and manoeuvring area(s) of a port approach can only be determined if the required service level, in terms of acceptable waiting times or turnaround times, is available [Groenveld, 2001]. In general, the acceptable waiting times vary with the cost of a vessel, but no exact accepted criteria are available. To give an idea of applied maximum average waiting times:

- Container vessels: 5-10 % of the service time (time to unload and load a vessel)
- Gas carriers: 10 % of the service time
- General cargo: 30 % of the service time
- Liquid bulk carriers 30 % of the service time
- Ore carriers: > 40 % of the service time
- Cruise vessels: 30 minutes

Because of low traffic intensity at the start of a new port development, a one-way channel may be sufficient, but for the development of a master plan in the concept design stage, the ultimate traffic intensity has to be applied to highlight/reserve the required space.

Although somewhat complicated, queuing theory can be used in Concept design to make a first estimation of the waiting times. To this end the port approach system has to be schematised to a simple service system (see Figure 3.7). For the estimation of the capacity of an approach channel, it should be realised that the part of the chain with the lowest capacity determines the capacity of the approach system as a whole. Usually, the approach channel ends in a turning basin, where ships will turn before being berthed. For safety reasons, when a ship is using this area as a turning basin, no other ship is usually allowed to be in this area. The turning basin is therefore the element with the lowest capacity, as the dwell time during manoeuvring usually exceeds the separation time between vessels in the straight or curved part of the channel.

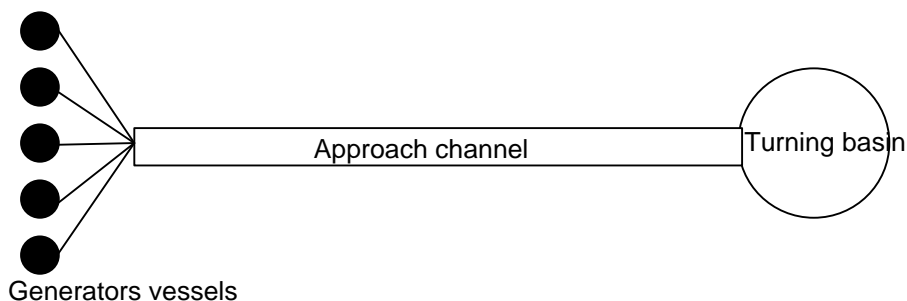

Figure 3.7: Approach channel with turning basin

Considering a simple two-way channel ending in a turning basin queuing theory can be applied. Suppose vessels arrive according to a negative exponential distribution indicated by the letter M (Markov) and suppose the average dwell time can be considered as a

deterministic value (D) the system can be described by an M/D/1 system. Then, the 'M' stands for the inter-arrival time distribution, 'D' for the service time distribution and '1' means the system is using only one service point (the turning basin).

The density function of a Negative Exponential Distribution (NED) is:

$$f(t) = \lambda e^{-\lambda t} \quad (3-1)$$

where λ = arrival rate and t = service or dwell time (dwell time in the turning basin).

Table 3.1 shows ship waiting times expressed in units of average service time (dwell time in the turning basin).

Utilisation	0.1	0.2	0.3	0.4	0.5	0.6	0.7	0.8	0.9
Waiting time	0.06	0.13	0.21	0.33	0.50	0.75	1.17	2.00	4.50

Table 3.1: Average waiting times of ships in units of the average service time of an M/D/1 system

If the dwell time of the ship varies quite strongly, an M/M/1 (i.e. Markov/inter-arrival time distribution/one service point), system can be used. Waiting times in units of the average dwell time are given in Table 3.2.

Utilisation	0.1	0.2	0.3	0.4	0.5	0.6	0.7	0.8	0.9
Waiting time	0.11	0.25	0.43	0.67	1.00	1.50	2.33	4.00	9.00

Table 3.2: Average waiting times of ships in units of the average service time of an M/M/1 system

If the dwell time of ships varies in a modest manner an M/E2/1 system can be used, where 'E2' stands for an Erlang-k distribution with $k = 2$ (shape parameter), μ = service rate (number of ships that can be handled per time unit) and t = dwell time. The density function of an Erlang-k distribution is:

$$f(t) = \frac{(k\mu)^k t^{k-1} e^{-k\mu t}}{(k-1)!} \quad (3-2)$$

Average waiting times for this example are listed in Table 3.3.

Utilisation	0.1	0.2	0.3	0.4	0.5	0.6	0.7	0.8	0.9
Waiting time	0.08	0.19	0.32	0.50	0.75	1.13	1.75	3.00	6.75

Table 3.3: Average waiting times of ships in units of the average service time of an M/E2/1 system

For Concept Design, the queuing theory systems mentioned above could provide adequate information. However, in many cases, the estimation of the capacity of the approach to a port is not a simple process and due to the complexity, queuing theory can no longer be applied. For instance, when dealing with traffic regulations, tidal windows and different ship types with different service levels and safety levels need to be considered. In such cases, traffic flow simulation models should be used in the Detailed Design stage.

3.1.4.1 Example 1

Suppose 15,000 vessels per year call at a port. The approach to the port is two-way, but only one vessel at a time is allowed in the turning basin (see Figure 3.7). The inter-arrival times of incoming vessels are negative exponential distributed (M) and the dwell time of the vessels in the turning basin is constant (D) and equal to 25 minutes. The outgoing vessels will stay on average 5 minutes in the turning basin.

To determine the waiting times for the incoming vessels, the available time of the basin is determined for the incoming vessels: $365 * 24 * 60 - 15,000 * 5 = 525,600 - 75,000 = 450,600$ minutes. The total required dwell time of the incoming vessels is: $15,000 * 25 = 375,000$ minutes. For incoming vessels the occupancy of the turning basin or utilisation is $375,000/450,600 = 0.83$. According to Table 3.1, this leads to an average waiting time of 2.75 in units of the average dwell time, or $2.75 * 25 = 69$ minutes.

If the distribution of the dwell time is very irregular, an M/M/1 system can be applied. Using the same values as above with Table 3.2, an average waiting time of 138 minutes is calculated. The example shows that a careful estimation of dwell time distribution is important. If only the approach channel is considered and waiting times are not affected by the presence of a turning basin, the safety distance between vessels can be used as the dwell time.

3.1.4.2 Example 2

Suppose again a two-way approach channel with a volume of 15,000 vessels per year (Figure 3.8). Safety distances (D) are 5 minutes and do not vary and inter-arrival times are again negative exponential distributed so an M/D/1 system can be applied. No overtaking is allowed. According to Table 3.1 with occupancy of 15 %, the average waiting times in units of the average service time (dwell time) is 0.09. This means that the waiting time is $0.09 * 5 = 0.45$ minutes which can be neglected. When dealing with dangerous cargoes, for instance LNG carriers or LPG carriers, separation times of 20 to 30 minutes might be required. This may lead to much higher waiting times for these types of vessels, but also the waiting times of other vessels will increase.

When considering a one-way approach channel or a partly one-way channel, waiting times are based on the dwell times in the one-way channel part, depending on the length of this one-way part and in case of intensive traffic. This may lead to much higher waiting times not only for these types of vessels but also for other vessels. In such situations, traffic regulations will be required and due to this complexity queuing can no longer be applied. In this case, traffic flow simulation models should be used.

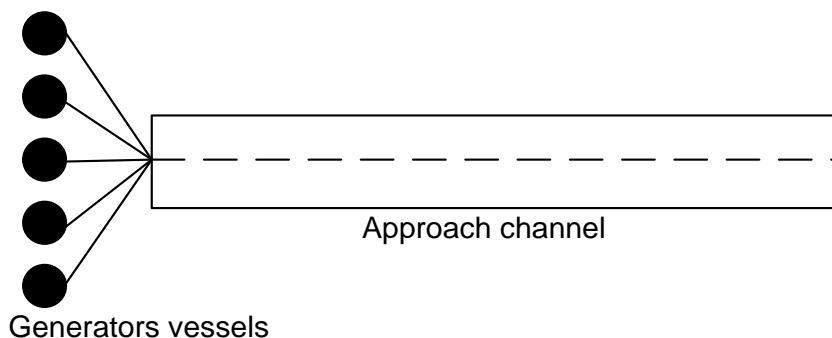

Figure 3.8: Approach channel with 2 lanes

3.1.5 Concept Design Methods for Straight Channels

This section presents recent modern practice in channel width design that should provide adequate navigational safety in the Concept Design phase. Although it can be applied to access channels world-wide, local conditions may require an optimisation with respect to cost, operational conditions and environmental aspects, which may be carried out using the Detailed Design methods.

The overall bottom width W (see Figure 3.2) of an access channel with straight sections is given for a one-way channel by:

$$W = W_{BM} + \sum W_i + W_{BR} + W_{BG} \quad (3-3)$$

and for a two-way channel by:

$$W = 2W_{BM} + 2\sum W_i + W_{BR} + W_{BG} + \sum W_p \quad (3-4)$$

where:

W_{BM} = width of basic manoeuvring lane as a multiple of the design ship's beam B , given in Table 3.4

$\sum W_i$ = additional widths to allow for the effects of wind, current etc, given in Table 3.5

W_{BR} , W_{BG} = bank clearance on the 'red' and 'green' sides of the channel, given in Table 3.6

$\sum W_p$ = passing distance, comprising the sum of a separation distance between both manoeuvring lanes W_M (see Figure 3.2) and an additional distance for traffic density, given in Table 3.7.

3.1.5.1 Basic Manoeuvring Lane W_{BM}

Table 3.4 lists the basic manoeuvring lane widths W_{BM} for ships with good, moderate and poor ship manoeuvring characteristics. Manoeuvrability of tankers and bulk carriers are considered to be generally poor; container vessels, car carriers, RoRo vessels, LNG and LPG vessels moderate; while twin-propeller ships, ferries and cruise vessels are generally good.

Ship Manoeuvrability	Good	Moderate	Poor
Basic Manoeuvring Lane, W_{BM}	1.3 B	1.5 B	1.8 B

Table 3.4: Basic manoeuvring lane W_{BM}

3.1.5.2 Environmental and Other Factors W_i

The manoeuvring lane W_M (see Figure 3.2) consists of the basic manoeuvring lane W_{BM} plus additional widths W_i to account for environmental and other navigation effects on manoeuvring. Table 3.5 lists these environmental allowances as a function of ship speed and channel exposure to waves (also see the notes following this table). In general, use of this table in selecting channel width dimensions should be based on operational limit conditions if they are known. If not known, then prevailing conditions can be used. For instance with cross winds, it is not necessary to dimension for a 33 knot wind if the operational limits restrict the use of the channel to winds of 30 knots or less.

Width W_i	Vessel Speed	Outer Channel (open water)		Inner Channel (protected water)		
(a) Vessel speed V_s (kts, with respect to the water) $V_s \geq 12$ kts $8 \text{ kts} \leq V_s < 12$ kts $5 \text{ kts} \leq V_s < 8$ kts	fast			0.1 B		
	mod			0.0		
	slow			0.0		
(b) Prevailing cross wind V_{cw} (kts) - mild $V_{cw} < 15$ kts ($<$ Beaufort 4) - moderate $15 \text{ kts} \leq V_{cw} < 33$ kts (Beaufort 4 - Beaufort 7) - strong $33 \text{ kts} \leq V_{cw} < 48$ kts (Beaufort 7 - Beaufort 9)	fast			0.1 B		
	mod			0.2 B		
	slow			0.3 B		
	fast			0.3 B		
	mod			0.4 B		
	slow			0.6 B		
	fast			0.5 B		
	mod			0.7 B		
	slow			1.1 B		
(c) Prevailing cross-current V_{cc} (kts) - negligible $V_{cc} < 0.2$ kts - low $0.2 \text{ kts} \leq V_{cc} < 0.5$ kts - moderate $0.5 \text{ kts} \leq V_{cc} < 1.5$ kts - strong $1.5 \text{ kts} \leq V_{cc} < 2.0$ kts	all	0.0		0.0		
	fast	0.2 B		0.1 B		
	mod	0.25 B		0.2 B		
	slow	0.3 B		0.3 B		
	fast	0.5 B		0.4 B		
	mod	0.7 B		0.6 B		
	slow	1.0 B		0.8 B		
	fast	1.0 B		-		
	mod	1.2 B		-		
	slow	1.6 B		-		
	(d) Prevailing longitudinal current V_{lc} (kts) - low $V_{lc} < 1.5$ kts - moderate $1.5 \text{ kts} \leq V_{lc} < 3$ kts - strong $V_{lc} \geq 3$ kts	all	0.0			
		fast	0.0			
mod		0.1 B				
slow		0.2 B				
fast		0.1 B				
mod		0.2 B				
slow	0.4 B					
(e) Beam and stern quartering wave height H_s (m) $H_s \leq 1$ m $1 \text{ m} < H_s < 3$ m $H_s \geq 3$ m	all	0.0		0.0		
	all	-0.5 B		-		
	all	-1.0 B		-		
(f) Aids to Navigation (AtoN) - excellent - good - moderate				0.0		
				0.2B		
				0.4 B		
(g) Bottom surface - if depth $h \geq 1.5 T$ - if depth $h < 1.5 T$ then - smooth and soft - rough and hard				0.0		
				0.1 B		
				0.2 B		
(h) Depth of waterway h		$h \geq 1.5 T$	0.0 B	$h \geq 1.5 T$	0.0 B	
		$1.5 T > h \geq 1.25 T$	0.1 B	$1.5 T > h \geq 1.15 T$	0.2 B	
		$h < 1.25 T$	0.2 B	$h < 1.15 T$	0.4 B	
(i) High cargo hazards		See explanation in box(i) overleaf				

Table 3.5: Additional widths W_i for straight channel sections

Notes and Explanation of Table 3.5:

Box b for cross winds

The additional widths refer to all ships with a balanced ratio between windage surface and lateral underwater area. These ships include (a) tankers and bulk carriers/OBOs (Ore/Bulk/Oil) in full load or ballast condition and (b) container ships, cargo vessels (freighters), car carriers and LNG/LPG vessels. For high-sided ferries, cruise liners, RoRo vessels and car carriers with higher ratios of Windage Area / ($L_{pp} T$), a supplementary amount of 0.2 B should be added to the values in this box.

Boxes c and d for currents

If currents vary along a long channel, it is recommended that the required width is calculated at various key points along the length of the channel. Although cross-current magnitudes up to 2.0 knots are shown in Table 3.5, it is recommended that the channel should be realigned to avoid such high cross-currents if possible.

Box e for waves

This box gives a rough indication only and should be used with a degree of caution. Wave direction relative to the ship should be taken into account (head, beam or following seas). Head and following seas affect the UKC and encounter period (and hence heave and pitch), while beam seas mainly cause roll that affects UKC and the drifting of the ship affecting the channel width.

Box f for Aids to Navigation (AtoN) and associated systems

For positioning of a ship in a channel, there are many optical, radar and electronic devices for the channel and on board the ship which require no or only small additional channel width. An indication for the terms 'excellent', 'good' and 'moderate' are:

Excellent:

Channel:

- Paired lighted buoys with radar reflectors
- Lighted leading lines
- VTS, where applicable

With the availability of

- Pilots
- Differential global navigation satellite positioning systems (DGPS)
- Electronic chart display and information system (ECDIS)

Good:

Channel:

- Paired lighted buoys with radar reflectors
- Lighted leading lines

With the availability

- Pilots
- Differential global navigation satellite positioning systems (DGPS)

Moderate:

If anything less than the facilities mentioned above are available.

Box g for bottom surface

The effect of bottom surface is only important in shallow waterways. Smooth and soft materials including silt and mud can affect both the manoeuvrability and propulsion of a

ship (see Chapter 2 and Appendix E). Hard channel bottom surfaces (i.e. rock, coral) will produce greater damage due to grounding than soft surfaces. If the water depth h is greater than about 1.5 times the draught T of the design ship, no additional width is needed.

Box h for depth of waterway

This should be checked against ship speed (Froude Depth Number, see Chapter 2, section 2.1.2.4) and h/T ratio. The additional width at low UKC recognises the sluggish response that this implies should the ship be deflected off course for any reason.

Box i high cargo hazards

Cargo hazards are as prescribed in IMO and national regulations and include:

- Toxicity
- Explosive potential
- Pollution potential
- Combustion potential
- Corrosive potential

High cargo hazards include LNG, LPG and certain classes of chemicals. In general, no additional width is required in the presence of dangerous cargo. However, additional safety measures should be applied as, for instance, speed reduction in combination with VTS assistance and patrol vessels and/or restricting normally two-way traffic channels to one-way channels for a safe harbour approach.

3.1.5.3 Additional Width for Bank Clearance

Bank clearance is defined in Figure 3.6 for sloping channel edges. A ship close to the edge of its manoeuvring lane will experience bank effects which are at a controllable minimum. When dealing with very gentle slopes (1:10) and the water depth h_e above the level of the embankment is deeper than $0.75T$, the lowest value of Table 3.6 is recommended. Note that the values are the same for both outer and inner channels.

Width for bank clearance (W_{BR} and/or W_{BG})	Vessel Speed	Outer channel (open water)	Inner channel (protected water)
Gentle underwater channel slope (1:10 or less steep)	fast	0.2 B	0.2 B
	moderate	0.1 B	0.1 B
	slow	0.0 B	0.0 B
Sloping channel edges and shoals	fast	0.7 B	0.7 B
	moderate	0.5 B	0.5 B
	slow	0.3 B	0.3 B
Steep and hard embankments, structures	fast	1.3 B	1.3 B
	moderate	1.0 B	1.0 B
	slow	0.5 B	0.5 B
Note: 1. W_{BR} and W_{BG} are widths on 'red' and 'green' sides of channel			

Table 3.6: Additional width for bank clearance W_{BR} and W_{BG}

3.1.5.4 Additional Width for Passing Distance in Two-Way Traffic

To determine additional width for passing distance in two-way traffic (see Figure 3.2), the beam of the largest passing ship should be used whether or not it is the design ship. The values given in Table 3.7 are the distance between the lanes of a two-way channel (not the hull to hull distance as in Figure 3.11). Overtaking requires more width than passing, but is normally not considered in Concept Design. Heavy traffic is defined as more than 3 design vessels per day. In case of heavy (design) vessel traffic, an additional width of $0.5B$ could be added.

Width for passing distance W_p	Outer Channel (open water)	Inner Channel (protected water)
Vessel speed V_s (knots)		
- fast: $V_s \geq 12$	$2.0 B$	$1.8 B$
- moderate: $8 \leq V_s < 12$	$1.6 B$	$1.4 B$
- slow: $5 \leq V_s < 8$	$1.2 B$	$1.0 B$

Table 3.7: Additional width for passing distance in two-way-traffic W_p

3.1.5.5 Additional Width for Large Tidal Range

If there is a large tidal range (say in excess of 4 m) combined with strong currents and steep underwater banks on both sides of the channel, consideration should be given to the possibility of a ship blocking the channel. This might occur if a ship runs aground on one side of the channel, is turned by currents and runs aground with its stern grounded on the opposite bank. If a tidal window is applicable, the transit will normally take place around high water. In this scenario, the ship might be damaged at falling tide and may block the channel for an extended period of time. Under these conditions and on the basis of a proper risk study, a channel width that is wider than the L_{oa} of the design ship should be considered.

3.1.6 Concept Design Methods for Curved Channels and Bends

It is assumed the ship generally navigates the channel primarily unaided by tugs. Therefore, any bend connecting straight sections of a channel must take into account the ability of a ship to turn. This section gives values for additional width allowances due to the curves or bends in the channel.

3.1.6.1 Turning Radius and Swept Path

Figure 3.3 shows that the turning radius R_C and the additional width of the swept path ΔW are dependent on the depth to draught ratio h/T , the rudder angle δ_R , the bend angle α , and the ship type, length L_{oa} and beam B . For a given channel bend, the alignment and α determine a suitable R_C , see Appendix G (section G2.7, Eq. G2-25). In calm water with no wind, a hard-over turn may be accomplished by a ship having average-to-good manoeuvrability with R_C of about 2.0 to 3.0 L_{oa} in deep water, increasing to perhaps 5 or more L_{oa} at $h/T = 1.2$.

As a first approximation, Table 3-8 shows R_C for different ship types as a function of $h/T = 1.2$ and $\delta_R = 20^\circ$. For details of calculated values in Table 3.8, see Appendix G (section G2.7, Table G2-12). As it turns, a ship adopts a drift angle resulting in a path which is wider than its beam B . This excess swept path can vary from about 30 % to 40 % of B at $h/T = 1.10$, to 100 % to 160 % B in deeper water, depending on the depth of water.

Therefore, the way a ship turns depends very much on the h/T ratio. This affects both the radius of turn and width of the swept track. Hence, at the lowest h/T ratios, the radius will be at its greatest and the additional width at its smallest. Figure 3.9 illustrates swept path ratios (W_s/B) as a function of δ_R and h/T . Note that the swept path should not be confused with the basic manoeuvring lane. In determining bend radius and width, it is inadvisable to design bends which require hard-over rudder angles. This would give no 'reserve' of rudder to counter wind, wave or current and would therefore compromise safety. For Concept Design, it is suggested that turning radii and swept track width of the design ship at a steady rudder angle of less than hard-over should be used as a guide. Often ship-handlers are require 15° to 20° rudder in a bend, as greater values give too little margin for safety and smaller values (implying a large radius) make turning difficult due to the length of the track and the handling problems of keeping a ship accurately on track in a gentle bend. Without proper marking, the ship-handler can become disorientated in a bend (especially a long one), so extra width is required to compensate. Bends subject to cross-currents, winds and waves require even more additional width.

No.	Ship Type	R_c
1	Cargo ship	$5 L_{oa}$
2	Small cargo ship	$6 L_{oa}$
3	Container ship (over Panamax)	$7 L_{oa}$
4	Container ship (Panamax)	$6 L_{oa}$
5	Very Large Bulk Carrier	$6 L_{oa}$
6	Large Bulk Carrier (Panamax)	$6 L_{oa}$
7	Small Bulk Carrier	$5 L_{oa}$
8	VLCC	$5 L_{oa}$
9	Small Tanker	$5 L_{oa}$
10	LNG ship	$4 L_{oa}$
11	Refrigerated Cargo Carrier	$5 L_{oa}$
12	Passenger Ship	$4 L_{oa}$
13	Ferry Boat	$5 L_{oa}$

Table 3.8: Turning radius R_c as a function of ship type for $h/T = 1.2$

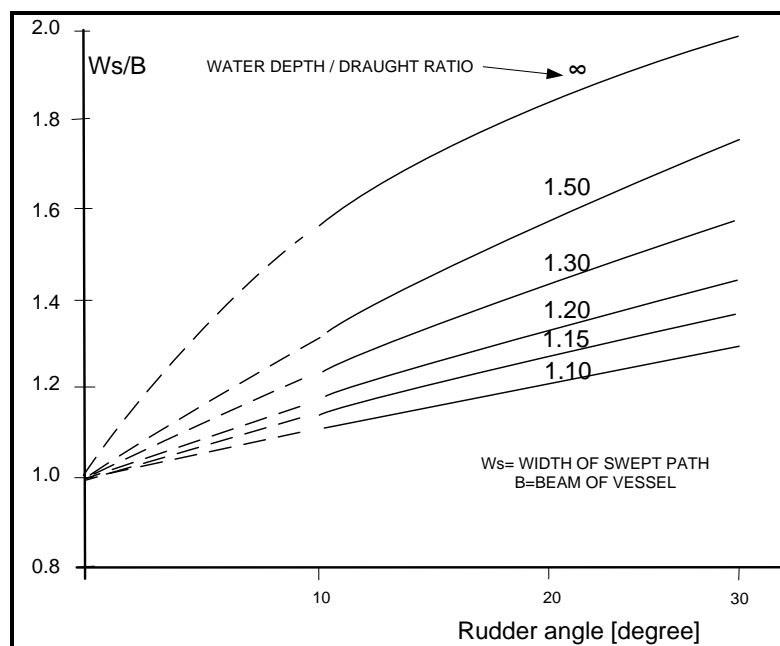

Figure 3.9: Width of swept track path in a bend as a function of rudder angle and water depth (based on a single screw/single rudder container ship)

3.1.6.2 Additional Widths in Bends

When transiting a bend in the approach channel the width of the swept path will increase [ROM, 3.1-99 ; Puertos del Estado, 1999]. This additional channel width ΔW is necessitated by increases in:

- Drift angle of the vessel
- Response time from the instant the vessel deviates from the channel axis and the moment when the correction becomes effective

Thus, the total additional width in a bend due to the swept path ΔW is equal to the sum of the additional width due to these two factors.

Additional Width Due to Drift Angle

The additional width due to the drift angle ΔW_{DA} can be determined by using the simplified formula:

$$\Delta W_{DA} = \frac{L_{oa}^2}{aR_C} \quad (3-5)$$

where:

ΔW_{DA} = additional width of the vessel's path swept due to drift angle in a curved channel section

R_C = bend radius (see Figure 3.3)

L_{oa} = length overall

a = factor depending on the ship type: $a = 8$ for normal ships and $a = 4.5$ for larger displacement ships with $C_B \geq 0.8$ (tankers, bulk carriers, etc.).

Additional Width Due to Response Time

An additional width ΔW_{RT} is required in bends to compensate for the time delay of the ship-handler in responding to a required alteration of course. In the Concept Design stage, the following allowance is recommended:

$$\Delta W_{RT} = 0.4B \quad (3-6)$$

3.1.7 Introduction to Spanish and Japanese Concept Design Standards for Channel Width

In some countries there are standards for the design of approach channels, two of which are Spain and Japan. These methods should be used when designing channels in those countries and accordingly, they are introduced in this section. It should be noted that the authors of the Spanish [ROM, 3.1-99] and Japanese (Japan Institute of Navigation, Standards Committee) methods are responsible for these design methods.

3.1.7.1 Spanish Recommendation for Maritime Works

The Recommendations for 'Designing the Maritime Configuration of Ports, Approach Channels and Floatation Areas' [ROM, 3.1-99] are part of ROM Programme (Recommendations for Maritime Works) as undertaken by Puertos del Estado in Spain. The Programme started in 1987 when the first Technical Commission was formed. Its mandate was to elaborate a set of recommendations collecting the most advanced technology in the field of maritime and port engineering, which would become a technical instrument for

designers, supervisors and builders. At the same time, it should provide different official institutions and private companies related to maritime engineering with easy access to the specialised information necessary for undertaking their work. The ROM is published in both Spanish and English.

The ROM presents criteria for the geometric layout of navigation channels, harbour basins and other port facilities, whether in maritime, river or lake areas. Requirements for the following navigation and manoeuvring areas are given according to the general provisions in the International Maritime Organisation (IMO):

- Channels, including shipping routes, approach channels and inland navigation canals
- Harbour entrances
- Manoeuvring areas, including vessel stopping and turning areas
- Anchorages and outer harbours
- Mooring berths and buoys systems
- Basins and quays
- Emergency areas
- Special facilities (shipyards, locks, etc.)

The aim of the ROM is to improve safety-risk assessment for maritime-port works. Specifically, the establishment of minimum safety requirements corresponds to a risk assessment which requires the progressive introduction of statistical models to analyse multivariate functions. The use of simulation models is also considered to accurately represent manoeuvrability of vessels as a function of their characteristics and the external actions.

The design procedure for a navigation channel or a harbour basin is as follows:

1. Determine the *lifetime* as a function of the *type of work* and the *safety levels* required, as well as the maximum *acceptable risk*
2. Establish characteristics of the *fleet of vessels* which will operate in the area. This will lead to the definition of the *design vessel(s)*
3. Quantify the *number of vessel operations* foreseen in the different target years. Annual accumulated information will generally suffice, unless traffic seasonality or environmental condition phenomena advise the use of shorter assessment periods (half yearly, quarterly, etc.)
4. Preset the maritime and meteorological *limit environmental conditions* for different vessel manoeuvres which may be carried out in the area under consideration. In the absence of other criteria, this Recommendation gives the environmental conditions usually considered as operating limits for each manoeuvre
5. Define the *geometric layout and dimensions* for each navigation area, taking into account the *AtoN* planned. Two procedures may be used in this design:
 - Deterministic – The geometric dimensions of the different areas are calculated by adding up several factors which, in most cases, lead to a specific, true result either using tabulated values or mathematical formulas. Tables and formulas may be a result of statistical analyses and a statistical processing might be used for some variables enabling dimensions to be associated to a risk level. Safety factors are used in the quantification of geometric dimensions

- Semi-probabilistic – Dimensioning is based on the statistical analysis of the space occupied by vessels in the different manoeuvres, enabling the resulting dimensions to be associated to the preset risk level with higher mathematical accuracy. The practical application of this method is based on simulation studies, scale model testing or field measurements. Safety factors can be considered in the statistical analysis (adequate exceedance probabilities) or as an additional safeguard to be added to the resulting dimensions
6. Determine the *down-time* for the navigation channels or harbour basins depending on the environmental limit conditions and the distribution functions of the weather variables considered
 7. In case a *cost-benefit analysis* is required, alternative solutions can be examined relating the operability of navigation channels or harbour basins to investments. These might consider reducing the operating limits in order to define a less expensive design or improving the provision of operational procedures (tug assistance, increased navigation aids, tidal windows, etc.). The basic criterion is that safety criteria must be maintained as economic optimisation must never involve a reduction in the safety required

3.1.7.2 Japanese Design Method

Design standards for port and harbour channel widths have been developed in Japan [Ohtsu et al, 2006 ; MLIT Japan, 2007]. Details on the use of this method are contained in Appendix G. Also, an Excel spreadsheet (J-Fairway) for the use of the Japanese method in the concept design stage is available for download at:

<http://www.ysk.nilim.go.jp/kakubu/kouwan/keikaku/J-Fairway-e.html>

It was developed by Japan Institute of Navigation, Standard Committee and Japan Ministry of Land, Infrastructure, Transportation and Tourism, National Institute for Land and Infrastructure Management.

The Japanese design method can be summarised by the following two features. The first feature is the performance-based design concept, which is widely and extensively employed nowadays in various design areas. Existing design methods are empirically-derived solely on the basis of experiences and statistical data, and are not necessarily based on rational grounds that may result in the limitations in their applications. The performance-based design, however, is developed primarily on the basis of theoretical considerations. Channel width elements can be estimated with the direct use of ship handling performance, such as the drift force on the fairway centre line. The performance-based approach possesses a wide and flexible applicability to various design requirements with respect to ship types and environmental conditions.

The second feature is practical estimation without the need of computers. In this design method, the well-established calculations of the ship manoeuvring motion [Inoue, 1981 ; Principle of Naval Architecture, 1981] are fully utilised so performance predictions can be made with sufficient accuracy. In the Concept Design phase, simple linear calculations and empirical formulae are derived from the fully nonlinear motion equations. Thus, the channel width determination can practically and easily be made without computers.

The channel width W is determined by the following basic equations.

$$W = (W_{BM} + W_{IF})C_{SF} \quad (3-7)$$

where,

W_{BM} = width of basic or fundamental manoeuvring lane

W_{IF} = additional width to account for interaction forces

C_{SF} = safety factor based on risk level

The value of W_{BM} is composed by the four basic elements as follows:

$$W_{BM} = a(W_{WF} + W_{CF} + W_{YM} + W_{DD}) \quad (3-8)$$

where,

W_{WF} = additional width to account for wind forces

W_{CF} = additional width to account for current forces

W_{YM} = additional width to account for yawing motion

W_{DD} = additional width to account for drift detection

a = channel width factor based on channel type

In addition, W_{IF} is composed of the following three elements.

$$W_{IF} = W_{BA} + bW_{PA} + cW_{OV} \quad (3-9)$$

where,

W_{BA} = additional width to account for bank effect forces

W_{PA} = additional width to account for two-ship interaction forces in passing

W_{OV} = additional width to account for two-ship interaction forces in overtaking

b and c = channel width factors based on channel type

3.1.8 Harbour Entrances and Manoeuvring Areas

3.1.8.1 Introduction

The harbour approach consists of four main components:

- outer channel section
- harbour entrance
- inner channel section
- turning basin

This harbour approach, from the upstream point where the ship starts with speed reduction to the most downstream point at the turning area, should be analysed (see Section 4.3.2).

In this section the stopping procedure, harbour entrance and turning basins will be discussed.

3.1.8.2 Stopping Procedure and Estimation of Stopping Distance

Manoeuvring of small to medium size vessels generally poses no specific issues in the dimensioning of port infrastructure. The required stopping lengths are limited and can usually be accommodated in traditionally sized inner channels and manoeuvring spaces. Manoeuvring capability of these vessels is generally good and upon entering port they will often manoeuvre and stop under their own power.

For large ships, however, the situation is different. Because of their much longer stopping distance and lack of course control during a stopping manoeuvre, they generally do not stop unassisted in constrained areas, especially for vessels of approximately 50,000 DWT and greater. As long as no effective tug control is available, such ships have to maintain a certain minimum speed through the water to ensure sufficient rudder control, necessitating tug assist in restricted areas.

In relatively sheltered water with little or no currents, slowing and stopping manoeuvres within port boundaries are determined by the following factors (Figure 3.10):

- Entrance speed of the ship
- Time required to attach tugs and to manoeuvre in position
- Actual stopping distance

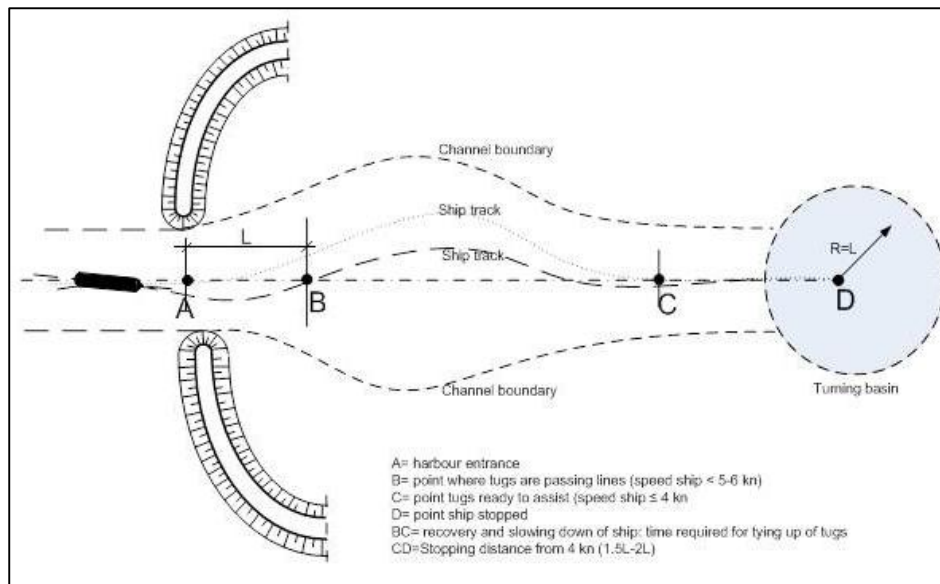

Figure 3.10: Stopping procedure and channel dimensions (Note: $kn=kt$)

Time Required to Attach Tugs and Manoeuvre into Position

The time required for attaching tugs (section BC in Figure 3.10) depends on the expertise of the crews and the environmental conditions. In average circumstances this can take 5 to 20 minutes. If a ship moves too fast or if the waves are too high, the tugs cannot attach while maintaining acceptable safety standards. The limiting speed is usually 5 to 6 knots and the limiting wave height is in the range of $H_s = 1.5$ to 3.0 m, depending on the tug, the skill of the crews and the possibility of attaching on the lee side of the vessel.

Ideally, tugs make fast as quickly as possible after passing inside protected waters or the port entrance, depending on the type of tugs available, and assuming that escorting is not required. This, of course, greatly reduces the stopping length required within the harbour. Very often, however, this will not be the case and tugs may have to wait until the ship is an appreciable distance inside the entrance before conditions are acceptable.

Actual Stopping Length

The actual stopping distance (section CD in Figure 3.10) is relatively short. Large ships give astern power the moment tugs can control the course and subsequently stop in approximately $1.5 L_{oa}$ to $2 L_{oa}$ from an initial speed of about 4 knots.

For example, if a ship has to carry out a stopping manoeuvre under the protection of breakwaters and enters the harbour at 6 knots, the stopping length to the centre of the turning basin is the combination of the following distances:

- The ship slows down to 4 knots over a period of up to 15 minutes while tugs manoeuvre into position. The distance travelled is up to about 2,300 m (section BC)
- Add a distance of L_{oa} immediately past the entrance before tugs can come near (section AB)
- Add the actual stopping distance of $2 L_{oa}$ (section CD)
- Total stopping length if $L_{oa} = 300$ m is: $900 + 2,300$ m = 3.2 km

As stated, for favourably located harbours where tugs make fast outside the harbour, the length of the breakwater can be reduced, but may lead to downtime under unfavourable weather conditions. In this case, tugs can attach and support a ship in a bend depending on speed, bend radius and wave conditions.

3.1.8.3 Harbour Entrance

The width of the harbour entrance should be equal to or wider than the length overall (L_{oa}) of the design ship to prevent the possibility of it becoming stranded across the entrance in the case of an incident.

3.1.8.4 Turning Basin

The turning basin is the area where vessels are often assisted by tugs to their berths and may be turned beforehand. In the Concept Design phase, the nominal diameter of the turning basin should be $\geq 2 L_{oa}$.

This turning basin diameter depends on the risks involved. If the environmental conditions are particularly adverse, (e.g. nearby hard structures, ships with dangerous cargo, strong currents or wind, harsh wave action, etc.) the designer may select a larger turning basin diameter. In the case of currents in a river port, or where there is a predominant strong wind, the turning area should be lengthened to allow the vessel to drift whilst being turned. In some cases, in particular for small ports, or where no tugs are available, the diameter should be $3 L_{oa}$. Of course, if the conditions are relatively benign or the risks are small, then the diameter could be reduced. However, it is usually prudent to delay the decision to reduce the diameter from a minimum of $2 L_{oa}$ to the Detailed Design phase.

If terminals are located along the boundary of a channel or river, the width of the channel or river may need to be widened to allow an appropriately sized turning area. When using such a turning area, other marine traffic will be prevented from using the channel which may cause additional waiting times. This could be avoided by placing the turning area outside the channel section, where possible, or through traffic management.

This conceptual design guidance for turning areas can be optimised or assessed in greater detail by using ship manoeuvring simulation, which can also be used to assess the requirements for manoeuvring in difficult situations, such as strong currents, heavy cross winds or a combination of both.

3.1.8.5 Clearance for Moored Ships

Passing ship effects need to be considered in navigation channels where a moored vessel is present. These effects are usually of concern where berths are located along relatively confined waterways and/or relatively close to navigation routes. In such locations, ships may pass relatively close to moored vessels while transiting to or from their berths. Such passing events may result in the disturbance of the moored vessels, which in some cases can cause disruption to cargo operations and excessive mooring line loads.

The passing ship effect is primarily generated due to a pressure field that is present around any ship that is underway (Figure 3.11). As a moving ship advances, it pushes water in front of it and out of its path. This results in an area of high pressure around the ship's bow. The water, accelerated by the high pressure, then flows along the hull sides in the direction of the stern, and this flow pattern gives relatively low pressure in the area along the sides of the ship. Finally, the moving water is brought to rest again in a high pressure region near the vessel's stern. The pressure distribution is therefore high pressure at the bow and stern, with low pressure amidships. The strength of the disturbance is greatest close to the moving vessel and decreases with distance from the ship.

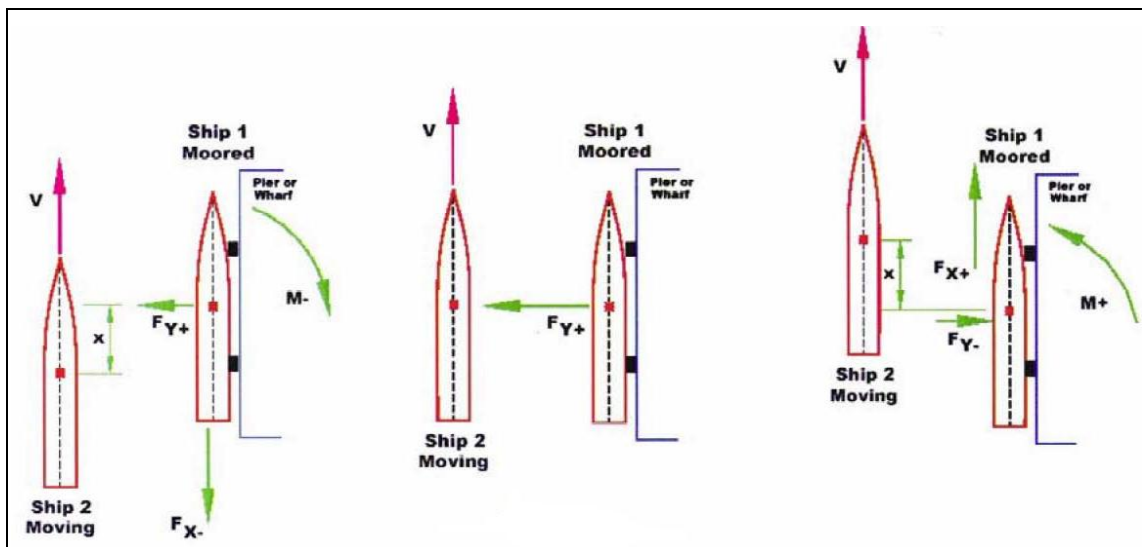

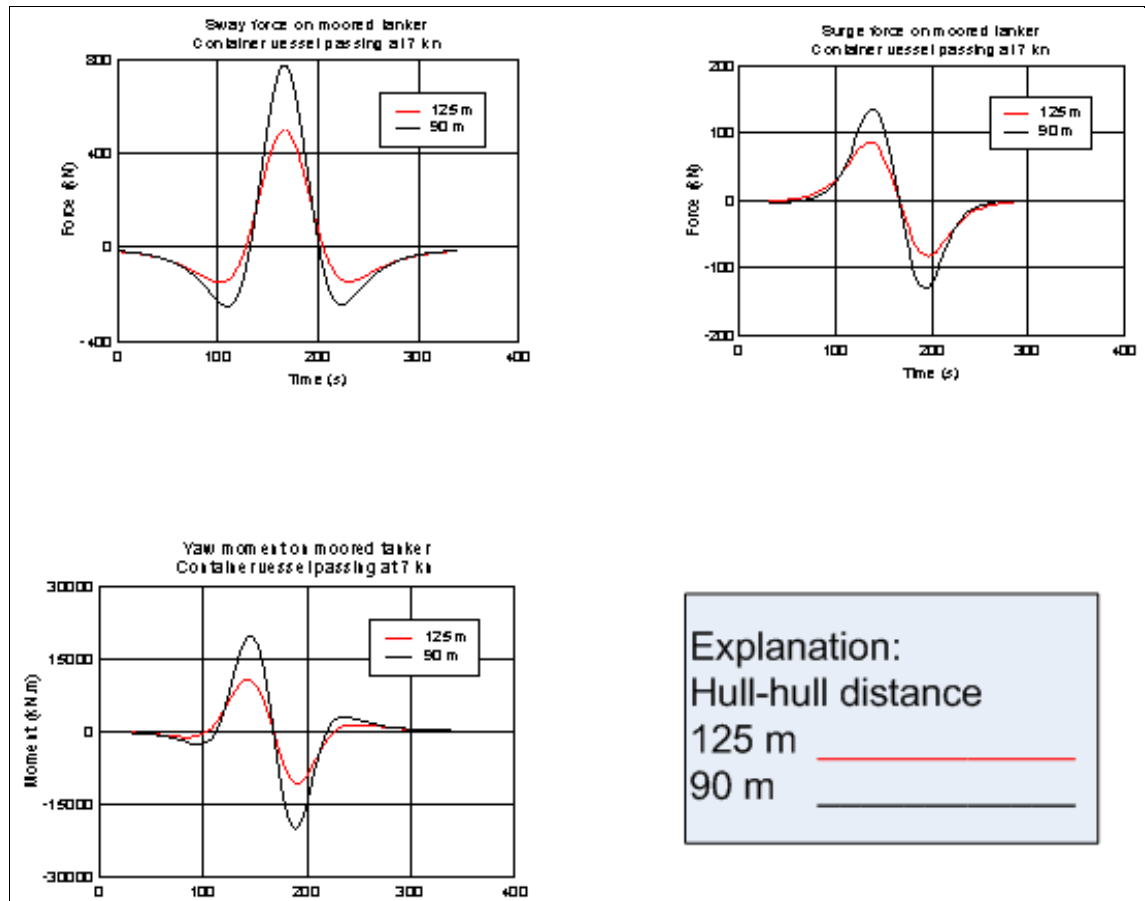

Figure 3.11: Forces on a moored ship.

Note that the distances are hull to hull in contrast to the passing distance W_p in Figure 3.2, and $ks=kn=knots$

The general pattern of effects on a moored vessel as a moving ship travels past is as follows:

- Repulsion as the high pressure field near the bow of the passing ship tends to force (sway force F_{y+} , yaw moment M_{-}) the moored and passing ships apart on approach
- As the passing ship draws level, the repulsive forces change to attraction (sway force F_{y-}) due to the low pressure region around the centre section of the passing ship and the moored vessel tends to swing out towards the passing ship
- As the passing ship starts to draw away, the moored vessel is initially drawn after it (surge force F_{x+}), being pulled into the low pressure area. This is the phase when moored vessel movements and mooring forces are usually largest. In particular, if the moored vessel is pulled out of contact with its fenders, the restraining effect of fender friction is lost and the vessel may move more. Experience shows that this is a critical threshold, where moored vessel movements can become significantly greater
- The attractive forces then change to repulsive as the effect of the high pressure at the stern of the passing ship becomes stronger. As a consequence, the moored vessel is pushed back towards the berth (sway force F_{y+} , yaw moment M_{+})

Passing ship effects may be more important in cases where the moored vessel is sensitive to motions, such as in the case of oil and gas terminals, and container berths. In the former, the oil and gas loading arms will have limitations on their movement and in the

latter case container cranes and guides demand relatively restricted movement while loading/unloading containers.

Operational limits need to be determined with regard to the speed and separation distance of the passing ships so interaction effects do not cause unnecessary disturbance to the moored vessel and possible damage to the lines and fenders. Otherwise, cargo handling activities may need to be suspended on the moored vessel, until the passing ship has passed.

The magnitude of the passing ship effects depend on a number of aspects, such as:

- Speed of the passing ship through the water, as the effects are proportional to the square of the moving ship's water speed. Therefore, this parameter should be carefully considered in the design and a realistic local speed range taken into account
- Separation distance between the passing and moored vessels, where the effects increase with decreasing separation distance
- Size of both the passing ship and the moored vessel, with larger ships, deep draughts and high block coefficients tending to generate greater passing effects and moored vessel movements
- Underkeel clearance of both the passing and mooring ships, where low underkeel clearances tend to increase the passing ship effects, as the blockage effect is higher
- Channel geometry, width and local bathymetry, where narrow channels or constrained waterways can accentuate the passing ship effect, again due to blockage effects

At the concept design stage, the following guideline for passing ship speeds and separations can be used to provide an indication of conditions that are unlikely to cause significant disturbance to a moored ship:

- Passing ship speed of 4 knots or less for a separation distance (hull side to hull side) of at least $2B$
- Passing ship speed should be 6 knots or less for a separation distance (hull side to hull side) of at least $4B$

For Detailed Design there are many dynamic computer models capable of determining the hydrodynamic forces between the two ships that can provide a site specific assessment of the passing ship effects.

Some indications on limiting values of moored ship movements compatible with commercial operations are given in the PIANC Report of Working Group no.24, 'Criteria for Movements of Moored Vessels in Harbours', Supplement to Bulletin no. 88, 1995. In addition, Working Group 52, 'Criteria for the (Un-)Loading of Container Ships', PIANC Report 115 (2012), has updated the recommendations of WG 24, with regard to container ships.

3.1.9 Anchorage Areas

3.1.9.1 Introduction

For the purposes of this guide, an Anchorage is defined as the area where vessels drop anchor either awaiting entry into port or to undertake cargo handling, passenger transfer, bunkering or other cargo operations associated with that port.

Anchorage are usually located in an outer harbour area or in the outer approaches to the port. However, under certain circumstances, anchorage area provision may be required within the working port area, for example, where the port lies along the banks of a river.

3.1.9.2 Design Factors

The design of an anchorage mainly depends on the following factors:

- Size, dimensions and characteristics of the design vessel(s)
- Type of operations expected to be undertaken
- Duration for which the vessel(s) will stay at anchor
- Site's general configuration and availability of space for manoeuvring
- Arrangement as a general anchorage area or have defined anchorage positions
- Number of defined anchoring points to be provided at the site
- Marine environment in the area and operational limiting conditions
- Site's physical characteristics and, in particular, depth and shape of the seabed and the ability of the bed material for anchor holding
- Availability of pollution combating resources

Anchorage Capacity

An anchorage must be of a sufficient size to allow a vessel or vessels to move unhindered with a suitable safety margin. Consideration should be given to likely time that vessels will need to stay at anchorage, design vessel length, length of anchor chain expected to be used and the clearance from nearby hazards or vessels should anchors drag. The general rule in shipping is that the vessel has to pay out an anchor chain length of at least five times the water depth to ensure a horizontal pull at the anchor. Assuming a dragging of the anchor of 30 m, the required minimum radius of a free weather-vaning anchorage R_A should be:

$$R_A = L_{oa} + 5h + 30 \text{ m} \quad (3-10)$$

Depth

The bathymetry of the anchorage should be relatively flat and clear of any obstructions which may foul an anchor. Due to the vessel's weather-vaning around its anchor, the vessel would experience vertical wave-induced motions which are less severe than in the channel, and no squat, except that which might be generated by a strong current. Anchorage areas may be protected from waves so wave motions can be relatively small. This means the underkeel clearance at anchorage does not have to be more than in an all-weather and tide navigation channel, or $1.1 T$ (Table 2.2).

Quality of the Holding Ground

The geographical location of the port will generally dictate the anchorage area and thus the nature of the seabed holding ground. Sailing directions usually give the type of seabed and quality of the holding ground, information that is important for assessing the suitability of an anchorage.

Protection from Wind and Sea

Where possible, the anchorage should be chosen with regard to prevailing winds and currents, so it provides the greatest natural shelter possible, whilst also endeavouring to achieve sufficient protection from wave effects.

Maritime Traffic in the Area

Preferable anchorages should not be located near busy shipping lanes to minimise the risk of a collision, especially with regard to the effects of fog and other phenomena which may reduce visibility.

Nautical Facilities for Taking and Leaving the Anchorage

As far as possible, an anchorage should be chosen which has suitable natural or artificial marking enabling the vessel to be accurately and safely positioned when approaching and whilst remaining at anchor.

3.1.9.3 Anchorage Design for a Vessel with One Anchor Ahead

The Spanish ROM3.1-99, gives detail examples of several anchoring scenarios including:

- Vessel with two anchors down
- Anchoring at ebb and flood
- Anchoring a vessel with one anchor ahead and one astern
- Distance between anchored vessels

The following is an example for the dimensions of the anchorage area for a vessel with one anchorage ahead. A vessel is said to swing with one anchor ahead when it pays out the chain to which the anchor is connected through the hawse hole (an opening in the hull at the top of the bow), allowing the anchor to dig into the seabed and remain as the only securing element. The chain is windlassed in to lift the anchor and the chain lifted out is stored in the chain locker and the anchor is lodged in the hawse pipe.

The swinging radius measured at the vessel's deck level can be calculated deterministically by adding together the following lengths (see Figure 3.12):

1. Vessel's length overall (L_{oa})
2. Length of chain it is expected to pay out at the anchorage. It is prudent to consider the total amount of chain available for the calculation to cover the possibility of having to pay it fully out because of heavy wind, waves or currents
3. An additional safety distance to cover anchoring inaccuracies, intended for errors such as those due to the inaccuracy of the method used for locating the position of the vessel to be anchored, or the vessel's run in the time elapsing between the moment the order to anchor is given and the time when the anchor holds in the seabed. Chart correctness and skill of the crew carrying out the operation are also important considerations. This safety distance depends on various factors and a value between 25 and 50 % of the L_{oa} of the vessel may be accepted
4. A suitable prior notice margin for the event whereby the anchor drags, which may be evaluated with the following criteria, determined as a function of the wind velocity (similar criteria could be set for separate or combined wind, wave or current action, considering the resultant of the longitudinal forces acting on the ship):
 - Good anchoring resistance seabed:

▪ Anchoring with wind velocity ≤ 10 m/sec	0 m
▪ Anchoring with wind velocity of 20 m/sec	60 m
▪ Anchoring with wind velocity of 30 m/sec	120 m
▪ Anchoring with wind velocity ≥ 30 m/sec	180 m

- Bad anchoring resistance seabed:
 - Anchoring with wind velocity ≤ 10 m/sec 30 m
 - Anchoring with wind velocity of 20 m/sec 90 m
 - Anchoring with wind velocity of 30 m/sec 150 m
 - Anchoring with wind velocity ≥ 30 m/sec 210 m

5. A safety clearance which may be 10 % of the L_{oa} , with a minimum 20 m (except for fishing and pleasure craft which may be reduced to 5 m)

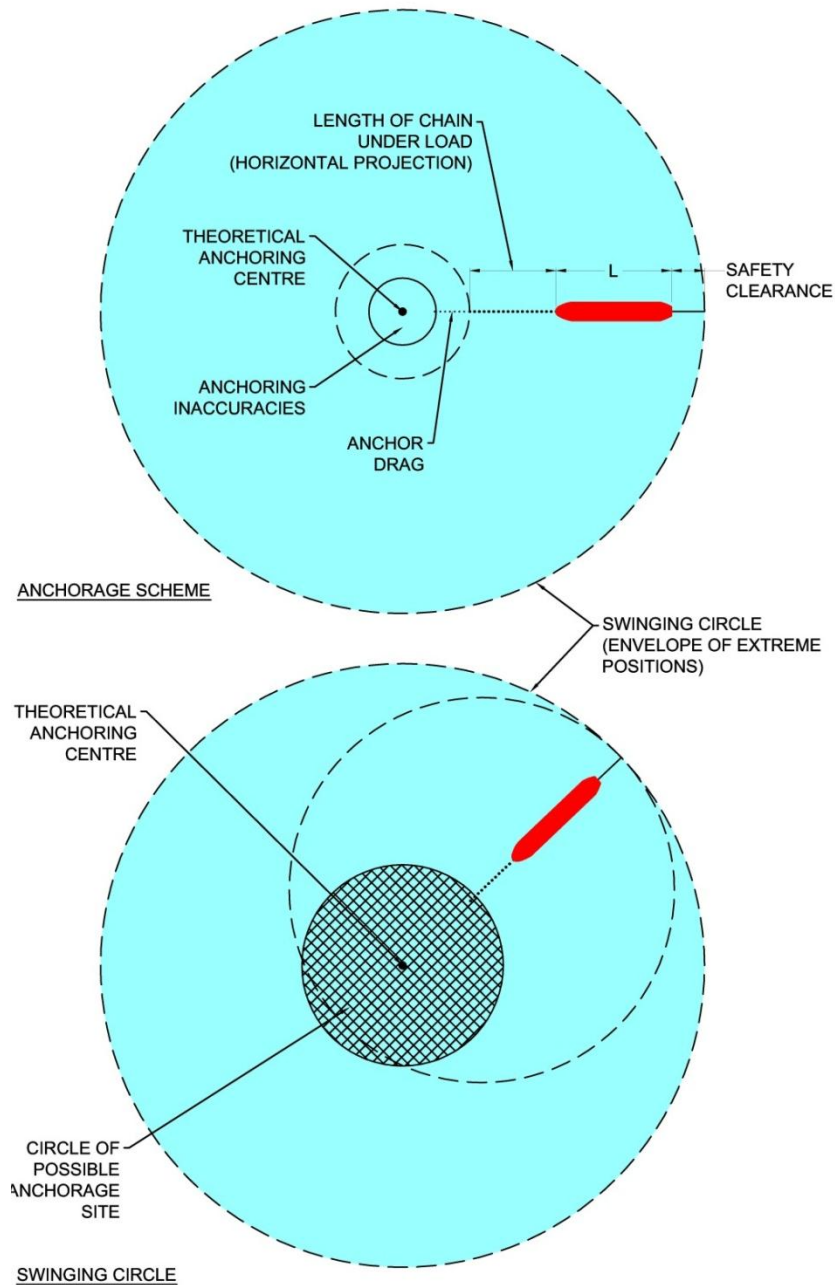

Figure 3.12: Swinging radius of a vessel with one anchor ahead

3.1.10 Pilot Boarding and Landing Areas

The IMO (International Maritime Organisation) resolution A960 prescribes the requirements for pilot boarding positions.

- The appropriate competent pilotage authority (defined) should establish and promulgate the location of safe pilot embarkation and disembarkation points
- The pilot boarding point should be at a sufficient distance from the commencement of the act of pilotage to allow safe boarding conditions
- The pilot boarding point should also be situated at a place allowing for sufficient time and sea room to meet the requirements of the master-pilot information exchange

Pilots will generally board and land from a ship via a SOLAS (Safety of Life at Sea) compliant ladder and boat. An area of sufficient size is required to enable a vessel to manoeuvre safely in order to provide an acceptable lee for the transfer that will accommodate all probable headings dependent on the prevailing local meteorological conditions. It should be recognised that unless it is at anchor, the ship will likely be underway at a speed of about 6 to 12 knots and, depending on the ship and prevailing conditions, may be required to maintain this heading and speed for up to 10 to 20 minutes. It is probable that the ship master will not alter from this heading until the pilot is on the bridge and has interacted with the master.

Some examples of pilot boat operational limits are given in Table 3.9.

Port	Significant wave height	Pilot vessel size
1. Elbe approach	$H_s = 3.5$ m	25 m swath
2. Brisbane	$H_s = 3 - 4$ m	13 m mono hull
3. Flushing & Rotterdam	$H_s = 3.5$ m	25 m swath
4. Istanbul	$H_s = 4$ m	17 m mono hull
5. Marseille	No defined limits	17 m mono hull
6. Rio de Janeiro	No defined limits	10 & 12 m mono hull
7. Dundee	$H_s = 4 - 5$ m (possible daylight)	15 m mono hull
8. Milford Haven	$H_s = 2.5 - 3.5$ m	16 m mono hull

Table 3.9: Examples of pilot boat operational limits

Where use is made of helicopters for boarding and landing, the same principles will apply. However, it may be that there is more predictability for the required heading with it possibly not being so dictated by the prevailing weather and sea conditions. Generally, the ship's course will be set for a minimum pitch and roll. As of 2012, there are no international standards pertaining specifically to pilot transfers by helicopter. However, the *International Chamber of Shipping Guide to Helicopter/Ship Operations* gives general advice and reference should be made to national and local regulations for port specific requirements. As an example, the national criteria of The Netherlands are specified in Table 3.10.

Pilot boarding by helicopter operations are suspended due to:
<ul style="list-style-type: none"> • High relative humidity in combination with temperatures < 0 °C (risk of icing) • Freezing rain • Thunder storms • Extreme snowfall or hail • Winds in excess of 55 knots (> 10 Beaufort) • Relative wind on deck under 25 knots (\leq 6 Beaufort), in case of hoisting only

Table 3.10: Pilot boarding limitations in The Netherlands

3.2 Detailed Design – Horizontal Dimensions

3.2.1 Motivation

While the Concept Design method can be used to arrive rapidly at an initial channel design, it is frequently necessary to carry out a more detailed assessment. The purpose may simply be to provide additional information to satisfy the owner/operators and the mariners who have to use the channel that it is satisfactory, or it may be to provide further input and refinement to the design. Other detailed design aspects involve the number, type and positioning of aids to navigation, consideration of detailed navigational aspects (such as navigation through bridges), or localised channel problems for which the recommended width requirements cannot be satisfied and where the channel cannot be realigned.

The basic approach involves the use of computer models whose type, purpose and methodology are simply outlined, but their use is discussed in more detail. The Detailed Design of channel width and alignment is considered using techniques which represent good present-day practice. As in Concept Design, width, depth and alignment are considered separately although, as already pointed out (and as will become obvious) they are all interlinked. The following are a number of items which may require Detailed Design consideration:

- Accuracy (human factors)
- Optimisation
- Benefits
- Critical factors including (a) cargo, (b) bottom conditions, (c) traffic intensity, (d) currents, (e) waves, (f) layout, (g) complicated ship handling, (h) special ships and (i) detailed hydraulic modelling

An introduction to tools and methods for Detailed Design is given in the following sections.

3.2.2 Tools and Methods

3.2.2.1 Detailed Parametric Design and Special Formulae

Detailed formulae with respect to external forces (wind, wave and current) acting on the manoeuvring ships, which were originally developed based on ship manoeuvring theory, are presented in Appendix G. The formulae for wind forces using non-dimensional force coefficients are also given in Appendix G (see also OCIMF 6.4, SIGTTO, Society of International Gas Tanker and Terminal Operators). As noted previously, the Spanish and Japanese authors are responsible for their own methods as presented in this Appendix.

3.2.2.2 Simulation Models

A number of different simulation tools are available for design studies and have different capabilities, functionalities and applications. Two types of simulation can be distinguished as:

- Ship navigation/manoeuvring simulation models
- Traffic flow simulation models

Ship navigation/manoeuvring simulation models are used to determine the width and alignment of channel sections and dimensions of manoeuvring areas, while traffic flow simulation models are used to determine the capacity of a port system as a whole.

3.2.3 Ship Manoeuvring Simulation Models

3.2.3.1 Introduction

Ship navigation/manoeuvring simulation systems have been developed to effectively evaluate and optimise the horizontal design of a navigation channel or harbour basin. They can usually be described as two main types:

- Fast-time simulation
- Real-time simulation

These simulation systems are both composed of simulation software, mathematical ship manoeuvring models, geographical area databases and replay and analysis tools. The main difference is that fast-time simulation uses autopilot algorithms to control the ship and tugs, whereas real-time simulation systems use a real mariner or marine pilot to control the simulated ship and tugs.

With respect to the bridge environment, real-time simulators for engineering design can have various levels of sophistication. Some can be very simple with a bridge view and control panel displayed on a single monitor or projection screen. Some can have a multi-screen display and even have real bridge controls for the pilot's direct use. The most advanced real-time simulators for approach channel and port layout design are full-mission simulators, which can also be used for pilot familiarisation and mariner training.

In general, similar simulation software, mathematical ship manoeuvring models and geographical databases are used for both types of simulator systems, but the study methodology is often quite different, as described in the following sections.

The highest manoeuvring accuracy of the mathematical ship manoeuvring models can be achieved if they are based on full scale data, such as trials data, model tank and/or wind tunnel tests, and then fine-tuned with other full-scale data. However, it is also possible to produce representative models based on numerical design and tested models of similar type and size of ships.

The simulator's geographical database describes the area where the simulations take place. The reality of the geographic representation depends on the available bathymetric, topographic and hydraulic data, which can influence the hydrodynamic response of the manoeuvring vessels and the visual scene for the pilots (in real-time simulation).

3.2.3.2 Fast-Time Simulation

A fast-time simulator is also sometimes referred to as an off-line or track-keeping simulator. It does not have a real pilot operating the ship, as it is not realistic to do so when running in fast-time. Instead, such simulators operate through the use of a number of equations which represent the behaviour of a pilot in controlling the ship and tugs. These are operated in such a manner so that the simulated ship is kept on a reference track. Figure 3.13 shows results of a single fast-time simulation.

They are generally operated through a 'look ahead' distance, which is used, in conjunction with a series of other parameters, to represent the necessary anticipation of the pilot. In addition, the ship's direction of travel is controlled by a form of autopilot, coupled to an engine control algorithm. Control of tugs is normally carried out through deterministic methods, using relatively simple algorithms and rules. All of these algorithms are used to control the ship based on the distance it drifts off the intended track, or from an intended position.

This form of simulation is considered appropriate for representing the behaviour of a pilot in certain circumstances. These include circumstances where the actions of the pilot are relatively straightforward and where the concept of a reference track is valid, such as for the design of relatively straight channels, or those without complex bends or series of bends. However, in the final stages of an approach to a port or berth, or when turning the ship in a turning area, these conditions may not be met. In such cases, it should be considered whether using fast-time simulation is valid and realistic. If fast-time simulations are not representative, real-time simulation should be used in conjunction with an experienced pilot(s).

To be effective, fast-time simulation studies need to use a large number of runs to enable some statistical analysis of the results. The autopilot is likely to consist of five or more principal parameters which may be varied to represent a range of human pilot actions. These may be expected to include the look-ahead distance, the gain, phase and integral amount of the autopilot algorithm and the maximum rudder which may be used. Additionally, the engine control and tug control algorithms will have a number of parameters. If the results are to be meaningful, a number of repeat runs need to be carried out for each operating condition, with the track-keeping parameters varied over a range to represent a range of operator performance. If this is not carried out, the process is equivalent to the same algorithm performing all the time and the results are reduced in validity. Approximately ten runs per scenario should be undertaken to represent an adequate level of study.

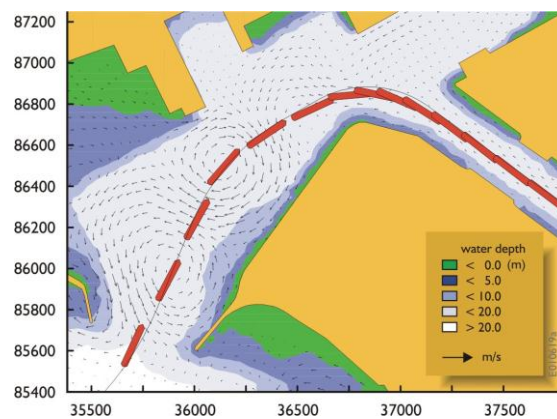

Figure 3.13: Fast-time simulation output

3.2.3.3 Real-Time Simulation

A more comprehensive tool for examination of ship navigation and manoeuvring is real-time navigation simulation. All the relevant visual and other information are provided to a human pilot, who is thus able to operate the ship and tugs in a realistic manner.

Real-time navigation simulation may be carried out on full bridge or part bridge simulators, which vary in the level of information presented to the pilot. The most critical aspect is the provision of an adequate visual scene, such that it can be effectively used by the pilot for manoeuvring. This normally requires a relatively large field of view involving a number of monitors or projected images such that the pilot's peripheral vision is filled with the simulated view. A real-time simulator should also have replicated ship's controls so the vessel can be controlled in a realistic manner.

Often full-mission simulators (Figure 3.14) may be available for use in real-time navigation simulation studies and for training activities. These are characterised by a wide visual field, which plays a critical role in the realism of the simulator and in the evaluation process. The use of real instrumentation and controls provides the mariners with as much bridge realism as possible. In this way the results, conclusions and recommendations can be based on a thorough review of technical aspects, as well as the important human factors, such as response times and communication.



Figure 3.14: Full mission simulator

The use of escort towing (indirect towing) in waterways is increasingly used to assist the constantly increasing size of vessels in both manoeuvring and navigation. Placement of AtoN and the width of the waterway should take such operations into account and require a highly realistic simulation tool for validation. During full-mission simulations, the design ship(s) and tug(s) (where applicable with integrated ship and tug bridge simulators) should be manoeuvred by experienced, professional mariners (pilots and tug masters), so that the outcome of the simulations is based on sound professional judgment and accepted best practice.

Verification of the final layout of a channel, port area or port modification should be studied using a full-mission simulator. Again, the full-mission simulations should be

carried out by pilots and tug masters who are familiar with the ships and studied environment. However, other experienced pilots and tug masters may be used where this is not possible. Port authorities and other relevant experts may contribute with expertise and practical experience to establish a sound basis for decision making.

The fundamental reason for emphasising the use of a full-mission simulator in combination with the above mentioned participation of relevant experts is because this is the only way to ensure that technical ship handling and the important human factors, are sufficiently incorporated. Safety margins should be carefully considered to evaluate required channel width for increasingly larger ships calling at the port.

For initial engineering evaluation and comparison of different design options, it may suffice to use a less advanced simulator, as mentioned in Section 3.2.3.1. Some of the more basic simulators are portable and can be taken to the pilots' base. This would allow a range of pilots to participate in the simulations, providing a wide range of results and may provide cost savings. However, for verification of the final design a full-mission simulator should be used.



Figure 3.15: Part-task simulator

3.2.4 Traffic Flow Simulation Models

The goal of traffic flow simulation studies is to determine the capacity of a complicated approach system. The capacity depends on physical characteristics of the approach system, environmental conditions, ship traffic characteristics and required service and safety level. The objective of a traffic flow simulation study is very often bipartite. The capacity can be determined based on the required service level and safety level [Groenveld, Onassis and van Wijhe, 2002] after specifying:

- Physical characteristics and environmental conditions of the approach system
- Vessel traffic volume to be handled with specification of different fleets and associated arrival patterns
- Operational rules (traffic rules) provided by manoeuvring simulation models

As stated before, the service level is usually expressed in terms of waiting times of the vessels. It should be stressed that waiting times are not only caused by occupancy of the different channel sections of the approach system, but also by berth occupancy. In a second exercise, the safety level of the approach system is determined.

In the present state-of-the-art, safety level is related to number of potential encounters. Thus, the capacity can be defined as the maximum traffic volume to be handled by the approach system while satisfying the required service and safety levels. Figure 3.16 is a schematic of the procedure for creating a traffic flow simulation model. Details of this procedure are provided in the following sections.

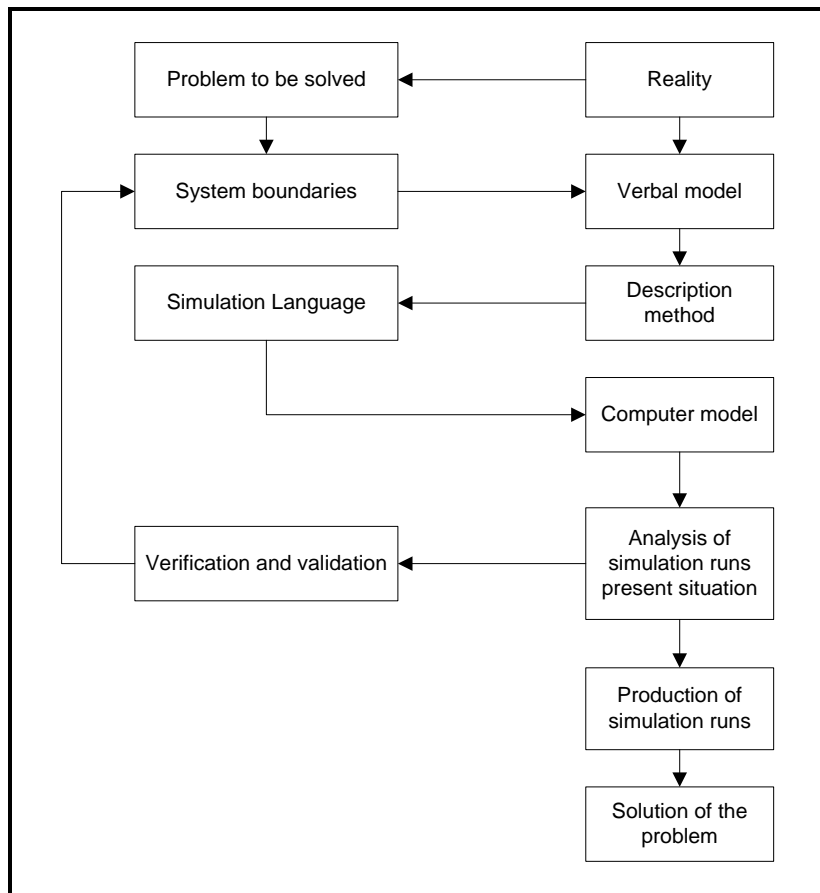

Figure 3.16: Steps in the simulation process

3.2.4.1 System Boundaries

First, the boundaries of the system have to be determined. System boundaries are dependent on the problem to be solved.

3.2.4.2 Model Description

In the next step, a description of the model is given. This means that within the boundaries of the system, reality has to be schematised. The measure of schematisation is dependent on the problem to be solved. The setting of boundaries and schematisation of the system is the most difficult part of the task. Irrespective of the planning objective (new channel existing channel, etc.), the level of detail to be applied in the different parts (modules) of the model is a very critical decision. Table 3.11 lists some basic differences between an outline and a detailed model.

Outline model	Detailed model
Advantages	
<ol style="list-style-type: none"> 1. Simple model development 2. Easy data preparation 3. Generally applicable results 	<ol style="list-style-type: none"> 1. Basic assumptions are simple 2. Additional details increase opportunities for studying system response
Disadvantages	
<ol style="list-style-type: none"> 1. Overall assumption may not be correct under all conditions 2. Assumptions are not clear and difficult to evaluate 3. Results are not detailed 	<ol style="list-style-type: none"> 1. Complicated model development 2. Results are specific for the particular system. Many simulation runs are necessary to check the various possibilities.
Possible reasons for rejection	
<ol style="list-style-type: none"> 1. Results may not be valid under certain conditions 	<ol style="list-style-type: none"> 1. Expensive 2. No sufficient data available

Table 3.11: The advantages and disadvantages of outline and detailed models

3.2.4.3 Simulation Language

Then, the 'verbal' model is converted to a computer model by using a suitable computer simulation language.

3.2.4.4 Verification and Validation

Verification and validation is carried out to check whether the model is functioning correctly and in accordance with reality. In the verification procedure the following items are checked:

- Are the input parameters and logical structure of the model correctly represented?
- Is the model implemented correctly in the computer code?

The goal of the validation process is to produce a model that closely represents true system behaviour so it may act as a substitute for the actual system. Validation (tuning of the model) is achieved through an iterative process of comparing the model results with reality [Groenveld, Beimers and Vis, 2003]. Discrepancies are used to improve the model. Obviously, infrastructure traffic volume data for the reference year should be available in this stage.

3.2.4.5 Capacity Estimation

Finally, to estimate the capacity of an approach system, the following steps should be taken:

- Determine acceptable waiting times for the different fleets
- Develop traffic prognosis for coming years
- Simulate the years for which traffic prognosis have been developed and determine maximum traffic volume satisfying the required service levels of the different fleets
- Determine the number of potential encounters for the maximum traffic volume
- Check whether the safety level suffices, and if not, reduce traffic volume or modify the traffic rules. It should be noted that by intensifying traffic rules, waiting times will go up and, as a result, the service level will go down

3.2.5 Traffic Flow Simulation Model to Determine Capacity

An approach system of a port with different fleet types combined with a complex layout of water areas can only be schematised as a complex system. This means that queuing theory is not applicable and a simulation technique has to be used. For the description of such a complex approach system, the 'process description method' or the 'object oriented method' is considered as an appropriate and efficient method. These methods describe the behaviour of each component and their interactions with other components in the modules of the model. The interaction between a component ship on arrival and the component VTS for permission to be granted to enter the port system are examples [Groenveld, 2006]. The model should simulate the ship movements from arrival buoy to the end of the approach channel, or if required, to the different berths in the harbour.

The structure of such a traffic flow simulation model consists of two parts:

- Definition part defines the structure of the model in terms of components, attributes of components and the interactions between components
- The dynamic part describes behaviour of the components in the various modules

Figure 3.17 shows the important components. Figure 3.18 shows the different types of attributes integer, real, character, macro (referring to a set of calculations carried out by a component), distribution (referring to a distribution function), point stream (referring to a stream of points). Table 3.12 lists the tasks of the components and modules.

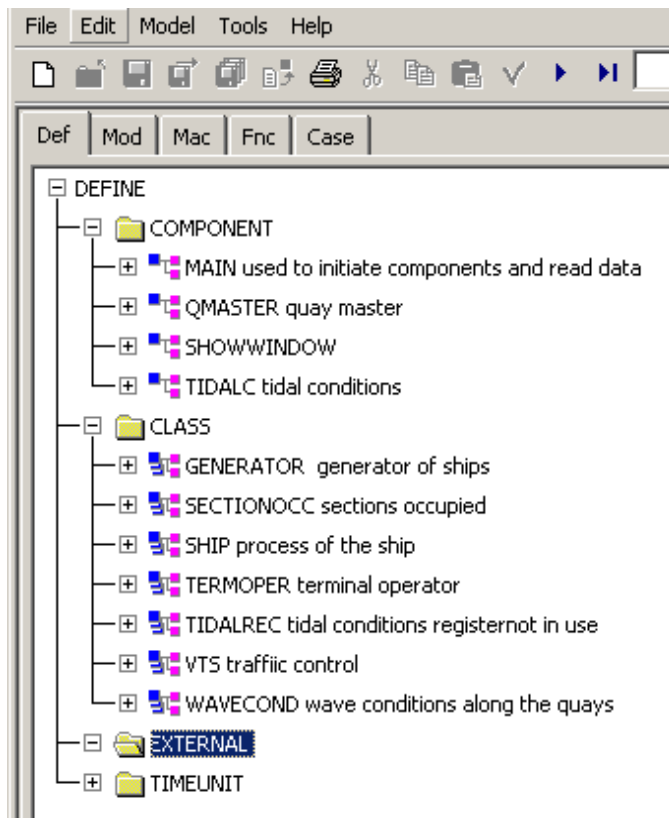

Figure 3.17: Definition of components

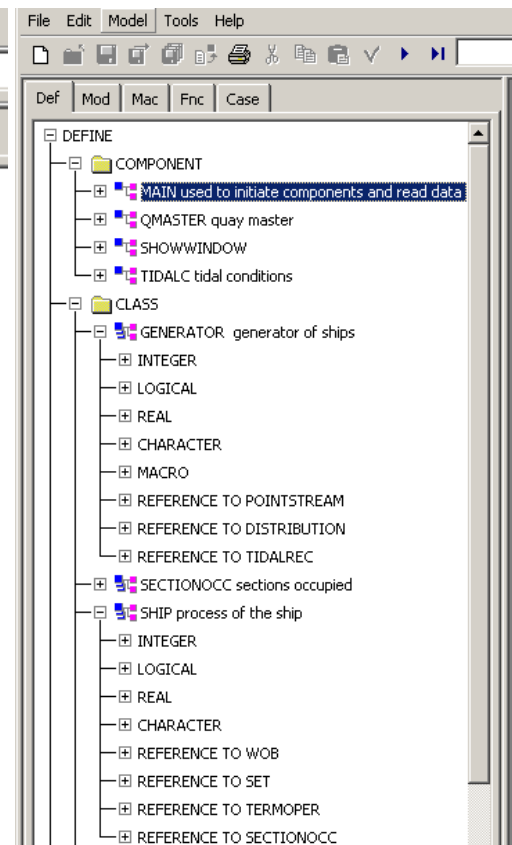

Figure 3.18: Types/attributes of components

Component	Process description
Generator	Generates ship traffic and assigns attributes of the ship
Ship	Describes process of the component ship
Quay master	Checks availability of quay and assigns berth to a requesting vessel
VTS	Checks tidal conditions and traffic situation
Terminal operator	Determines the service time (dwell time along the quay)
Tidal conditions	Determines tidal conditions
Tug	Registers number of tugs in operation
Section occupation	Reserves the occupation of a channel section

Table 3.12: Example components and modules of a traffic flow simulation model

3.2.5.1 Generator Component Process

For each fleet, the generator module creates ship arrivals according to the inter-arrival time distribution. A fleet is defined as a group of ships belonging to the same class with the same destination in the port. An inter-arrival time is the time between two successive arrivals of ships within the same fleet. For instance, approximately 40 generators have been used to generate ship traffic for the Port of Rotterdam.

When a ship has been generated, attributes are assigned as listed and described below:

- Ship class
- Ship length
- Draught and tidal windows
- Destination in the port
- Incoming and outgoing routes
- Ship speeds in the various channel sections
- Separation time with respect to other vessels
- Service time (mooring, unloading, loading and unmooring)

3.2.5.2 Ship Class

The ship class is used to specify traffic rules. For instance, to determine whether it is allowed to overtake or to meet another ship in a particular channel section.

3.2.5.3 Ship Length

The ship length is important to determine safety areas.

3.2.5.4 Draught and Tidal Window

The draught of the ship is important when dealing with tidal windows.

3.2.5.5 Destination in the Port and Incoming and Outgoing Routes

When a ship is generated, the incoming and outgoing routes are assigned. Moreover, dwell times in the relevant channel sections are given and in what way (normal sailing or manoeuvring) the ship is using the channel sections.

Table 3.13 gives an example of required input data for four incoming vessels with the same destination. This example concerns the simulation study carried out for Maasvlakte II of the Port of Rotterdam (see Figure 3.19). It is noted that mooring in section 26 is considered the same as manoeuvring here. When a ship is manoeuvring in an area, it is forbidden for another ship to be in this area at the same time.

Route	Incoming traffic to terminal destination 26								
	s1	s2	s4	s5	s18	s19	s20	s24	s26
	Ship type 2								
sailing times [min.]	26.9	11.3	6.1	2.7	3.8	4.7	4.7	0.5	20.0
sailing/manoeuvring	sailing	sailing	sailing	sailing	sailing	sailing	sailing	sailing	manoeuvring
	Ship type 3								
sailing times [min.]	26.9	15.1	7.3	3.2	7.6	9.5	9.5	1.1	20.0
sailing/manoeuvring	sailing	sailing	sailing	sailing	sailing	sailing	sailing	sailing	manoeuvring
	Ship type 4								
sailing times [min.]	26.9	15.1	9.1	4.1	7.6	9.5	9.5	1.1	30.0
sailing/manoeuvring	sailing	sailing	sailing	sailing	sailing	sailing	sailing	sailing	manoeuvring
	Ship type 5								
sailing times [min.]	44.8	22.7	12.2	5.4	7.6	9.5	9.5	1.1	30.0
sailing/manoeuvring	sailing	sailing	sailing	sailing	sailing	sailing	sailing	sailing	manoeuvring

Table 3.13: Example of an incoming route through the port system

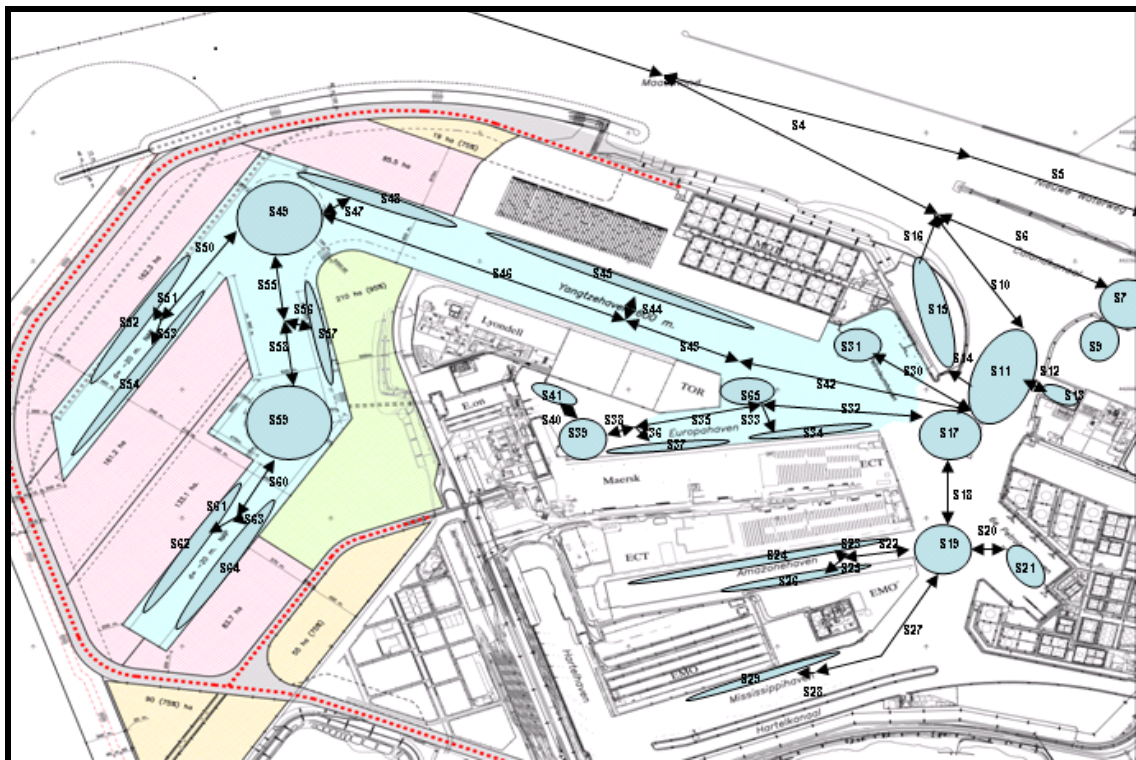

Figure 3.19: Port sections with manoeuvring areas

3.2.5.6 Separation Times

Separation times between vessels are based on safety considerations. Separation times are dependent on the vessel type. For instance, the separation time between a passenger vessel and a LNG carrier is much higher than between general cargo vessels.

3.2.5.7 Inter-Arrival Time and Service Time Distribution

As discussed previously, inter-arrival times and service times are determined by taking samples from a distribution function. Each ship generator of vessels from a certain fleet is provided with an inter-arrival time distribution and a service time distribution. Based on practical experiences, Negative Exponential Distributions (NED) can be used to describe the arrival process (see Figure 3.20) and Erlang-k distributions for the service process.

The density function of a NED distribution is:

$$f(t) = \lambda e^{-\lambda t} \quad (3-11)$$

where:

λ = arrival rate

t = inter-arrival time

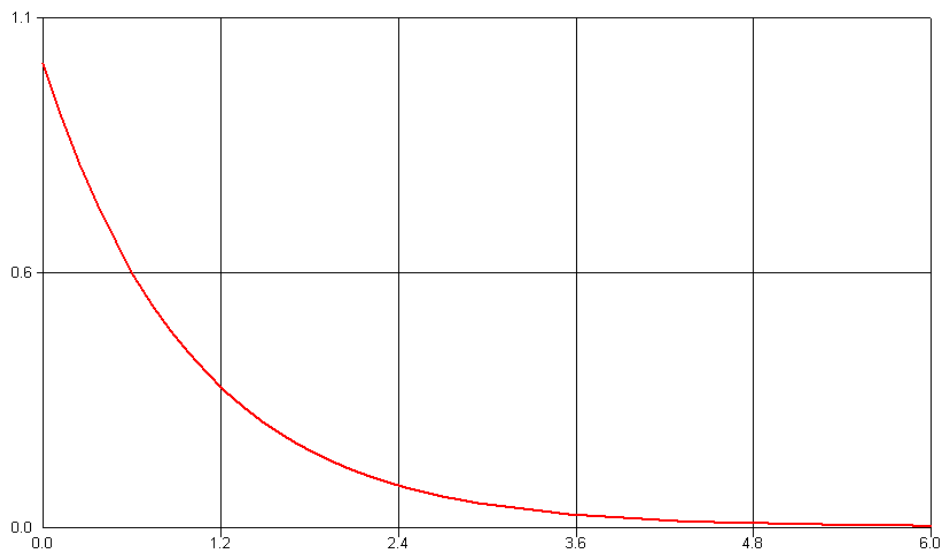

Figure 3.20: NED with $\lambda = 1$

The service times can be fitted to an Erlang-k distribution. The service time is supposed to be subdivided into a number of stages (mooring, unloading, loading and unmooring), so the Erlang-k is a natural choice since it has this characteristic. The Erlang-k distribution may be thought to be built up out of 'k' NED (see Figure 3.21). The mathematical formulation of the probability density function is:

$$f(t) = \frac{(k\mu)^k t^{k-1} e^{-k\mu t}}{(k-1)!} \quad (3-12)$$

where:

μ = service rate (number of services per time unit)

t = average service time

k = shape parameter, where higher k values lead to smaller variances.

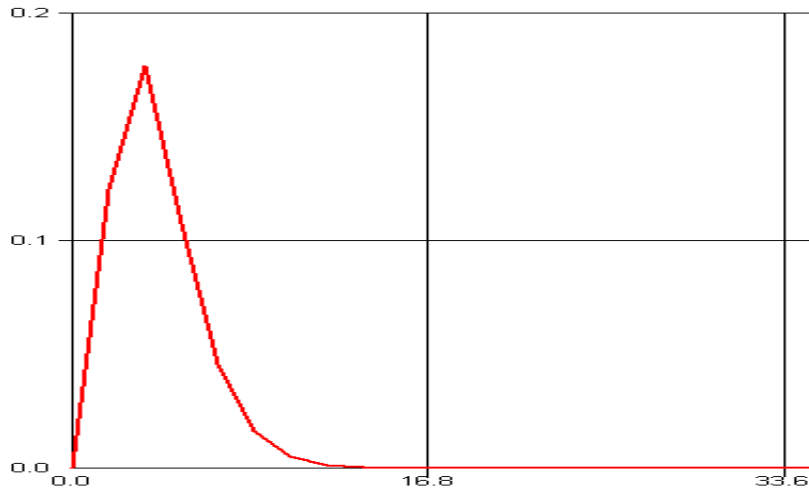

Figure 3.21: Erlang-k with $\mu = 4, k = 4$

3.2.5.8 Ship Component Process

A ship is generated by the corresponding generator and starts the process at the arrival buoy. On arrival, a berth is requested. Next the VTS-component checks currents, water levels and traffic situation. In case a problem exists, the ship has to wait and after a few minutes the situation is checked again. The ship transits to berth and after the service time, the VTS is again asked for permission to leave the port. The process of the ship and the interactions of the component ship with other components are given in Figure 3.22.

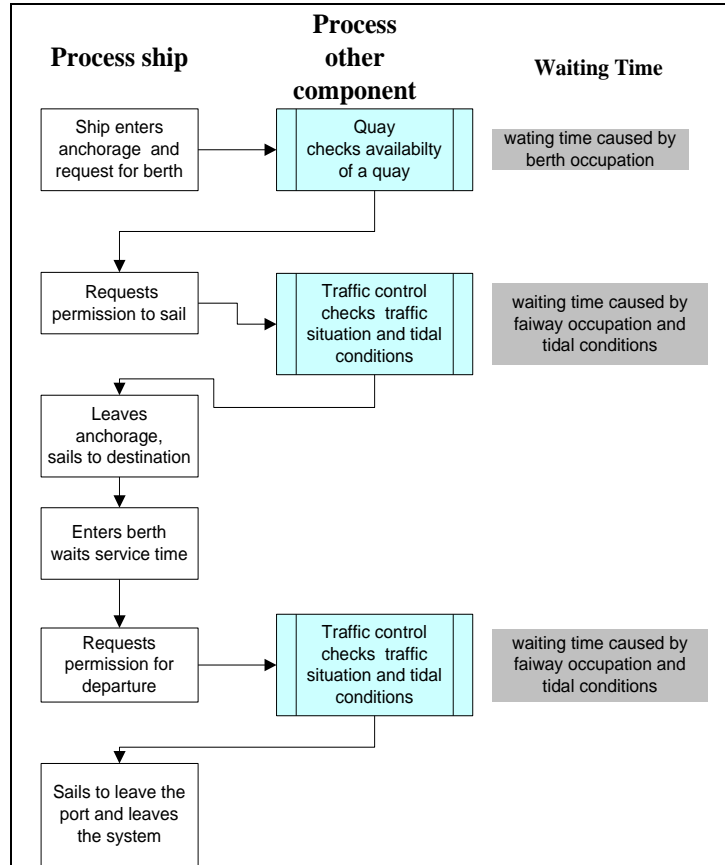

Figure 3.22: Ship component process

3.2.5.9 VTS Components Process

As indicated in the process of the ship, the VTS-components are checking currents, water levels (tidal windows) and ship traffic. To check ship traffic, the VTS component uses the ship traffic rules, or user-operating rules, specified for each port section (Figure 3.23). In principal two sail characteristics are distinguished:

- Normal sailing. Depending on the ship classes, ships are permitted to encounter or overtake each other
- Manoeuvring (turning circles and mooring basins). When a ship is manoeuvring, no other ship is allowed to enter the area



Figure 3.23: Ship traffic rules in manoeuvring areas and straight sections

As an example, Table 3.14 (input data) shows traffic rules for normal sailing in a channel section. Overtaking is not allowed for class 3 and class 4 ships (denoted by '0' in the table), while an encounter between class 3 and class 4 ships is permitted (denoted by '1'). In general, traffic rules for overtaking are stricter.

Section 4	Ship class, overtaking							
	1	2	3	4	5	6	7	8
Class 1	1	1	1	1	1	1	0	1
Class 2	1	1	1	1	1	1	0	1
Class 3	1	1	0	0	0	0	0	1
Class 4	1	1	0	0	0	0	0	1
Class 5	1	1	0	0	0	0	0	1
Class 6	1	1	0	0	0	0	0	1
Class 7	0	0	0	0	0	0	0	0
Class 8	1	1	1	1	1	1	0	1

Section 4	Ship class, encounter							
	1	2	3	4	5	6	7	8
Class 1	1	1	1	1	1	1	0	1
Class 2	1	1	1	1	1	1	0	1
Class 3	1	1	1	1	1	0	0	1
Class 4	1	1	1	1	1	0	0	1
Class 5	1	1	1	1	0	0	0	1
Class 6	1	1	0	0	0	0	0	1
Class 7	0	0	0	0	0	0	0	0
Class 8	1	1	1	1	1	1	0	1

Table 3.14: Ship traffic rules in port section

3.2.6 Traffic Flow Model to Determine Safety Levels

3.2.6.1 Introduction

In maritime transport, safety and efficiency are key issues. In quantitative safety analyses the term risk is defined as:

$$\text{Risk} = \text{Probability of occurrence of an accident} * \text{Consequence} \quad (3-13)$$

The general practice in conducting a risk assessment is to determine the risks that apply, then examine potential mitigation measures for any significant risk such that they are reduced to a risk level of As Low as Reasonably Practicable (ALARP). Further information on risk assessment is provided in Section 4.1.

According to Collwill et al. (2004): "In busy ports around the world, the hazard profile is dominated by ship-ship collisions' (internal safety)." Examples of measures to improve the safety in maritime transport are marking navigation channels by buoys, improved radar, introduction of internationally recognised Collision Regulations (COLREGs), VTS assistance and most recently, the introduction of the Automatic Identification System (AIS). Although maritime transport safety cannot be quantified accurately, it can be evaluated qualitatively.

In 2002 the IMO introduced the Formal Safety Assessment (FSA). However, the FSA methodology provides only a basis in theory but there is still a lack of uniformity in its applications [ISSC, 2006]. The IALA attempted to solve this problem by developing a Risk Management Tool for AtoN and VTS authorities. This tool includes a more detailed Quantitative Risk Assessment model called IALA Waterway Risk Assessment Programme (IWRAP).

A generally accepted approach to estimate collisions in restricted waterways is to simulate the vessel traffic in a specific area using traffic flow simulation models. In such programs vessels are generated according monitored arrival patterns and move along designated 'lanes' obeying traffic rules. To each vessel type a safety domain is assigned, representing a virtual area around the vessel that must be clear for safety purposes. For example, a small general cargo vessel will require a smaller safety domain than an LNG carrier with dangerous cargo. An encounter occurs whenever two vessels come within a certain distance to each other (entry of the safety domain). During the simulation, the model registers each time two vessels come within a set distance (safety domain) to one another as an 'encounter' and the associated conditions. By simulating various alternatives and comparing the number of encounters occurring in each, conclusions can be reached about the relative safety of different channel designs.

However, a relationship between the size of the safety domain of a vessel and the probability of a collision, in case of an encounter, is yet unknown. This method of encounters cannot be used on its own to predict maritime safety in terms of collision probability. Obviously, environmental conditions (wind, waves, currents and visibility), capability and behaviour of the crew of the vessel and the angle approach of the vessels influence the collision probability. The number of accidents can be determined based on historical data of collision probabilities per encounter type in certain areas. The number of encounters is used to evaluate future situations. By comparing the number of encounters occurring in the present situation with future situations, conclusions can be made regarding the relative safety of various channel designs.

3.2.6.2 Safety Domain

With respect to internal safety, potential encounters are registered and converted to encounter densities. As stated previously, a potential encounter is defined as an entry of another vessel in the safety domain of the vessel. This safety domain, especially in restricted waters, depends on:

- Maritime traffic situation (channel characteristics, traffic intensity, level of VTS management)
- Environmental conditions (wind currents, visibility)
- Fleet specification

Research has been undertaken into safety domains since the end of the 1960's. Figure 3.24 shows the variety of definitions of safety domains of vessels of approximately 100 m in length [Marin, Flanders Hydraulics, 2005].

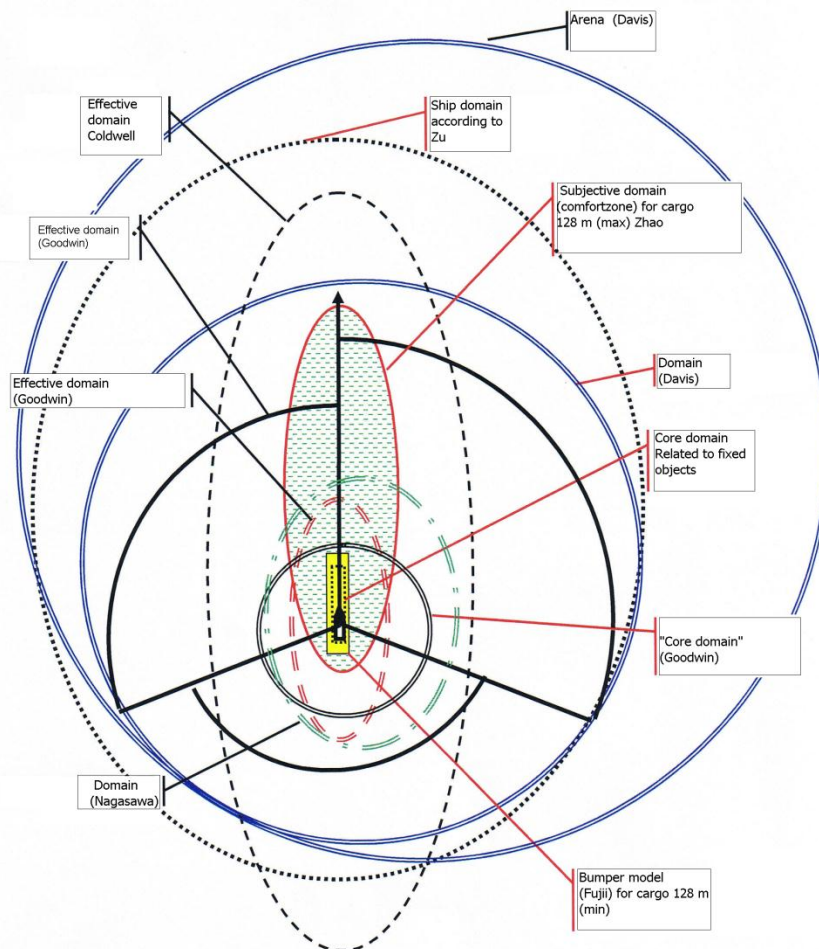

Figure 3.24: Vessel safety domains for vessels with a length of approximately 100 m [ten Hove et al., 2005]

In 2005 a study was carried out by Marin, Flanders Hydraulics and Dutch Logistic Development on free space around vessels in Western Scheldt, the approach channel to Antwerp [Marin, Flanders Hydraulics, 2005]. In this study, eight pilots, two port-captains and two VTS managers were interviewed. Table 3.15 shows results of the interviews with respect to required free space around a vessel. Mostly, the shape of the safety domain is elliptical.

Vessel type	Length [m]	Speed [knots]	Median value			
			Space in front [m]	Port side [m]	Starboard side [m]	Behind [m]
Container	300	16	500	100	100	300
Container	300	10	600	100	100	210
Container	200	16	450	100	100	200
Bulk	300	12	1000	100	100	250
Bulk in ballast	300	12	600	100	100	250
Bulk	250	12	775	100	100	250
Auto carrier	180	15	540	100	100	200
General cargo	120	12	500	90	90	200
LPG	118	12	500	90	90	150

Table 3.15: Safety domains, based on interviews

3.2.6.3 Vessel Paths

By using traffic flow simulation models, vessels move along designated lanes. To register the number of encounters, the track of each individual ship has to be determined. Therefore, assumptions have to be made with respect to the distribution of the ships over the width of the channel. Figure 3.25 shows an example of the lateral distribution of the position of a ship in a channel where Larsen showed the distribution in the Sont and Rotterdam VTS-operators the distribution in the entrance to Rotterdam.

For realistic vessel behaviour, each vessel should be provided with an avoidance algorithm to avoid another vessel or an obstacle. The formulation of the avoidance algorithm is not easy and depends on location, vessel type, vessel speeds and the angle between vessels. Moreover, the crew performance (experience, risk acceptance of the captain, etc.) is important.

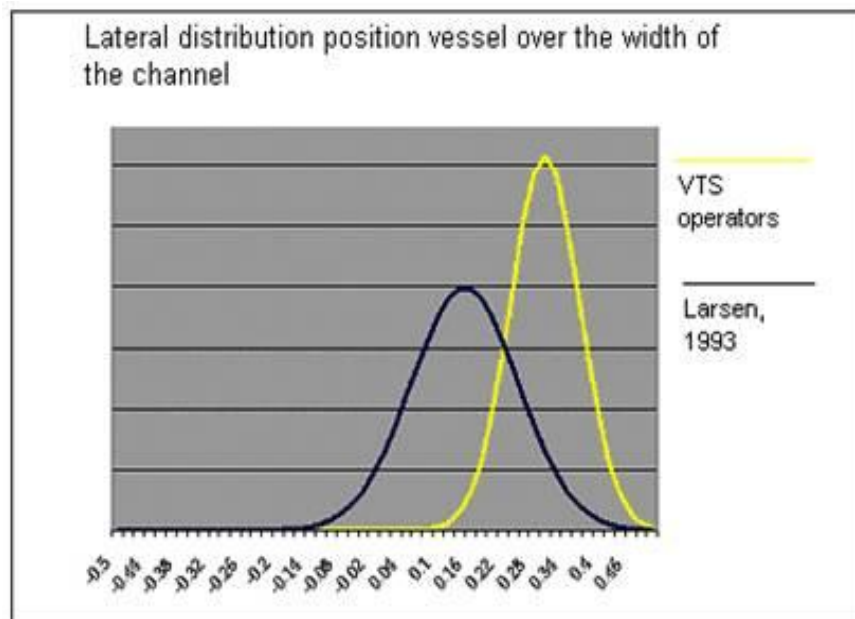

Figure 3.25: Lateral distribution ship position in the channel

3.2.6.4 Evaluation of Simulation Results

As stated previously, the capacity can be defined as the maximum traffic volume to be handled by the approach system satisfying the required service level and safety level. The estimation of required service level (expressed in waiting times) of the 'wet infrastructure' of a port system is not an easy matter. Ship owners and terminal operators are reluctant to provide acceptable waiting times and when they do, usually on the low side. Moreover, acceptable waiting times differ from fleet to fleet, from days for bulk carriers to a couple of minutes for container vessels. Regardless, consensus should be found for the wet infrastructure serving the different fleets of a port. As an example, the output of number of ships over time at anchorage (Figure 3.26) and the distribution of waiting times (Figure 3.27) are presented.

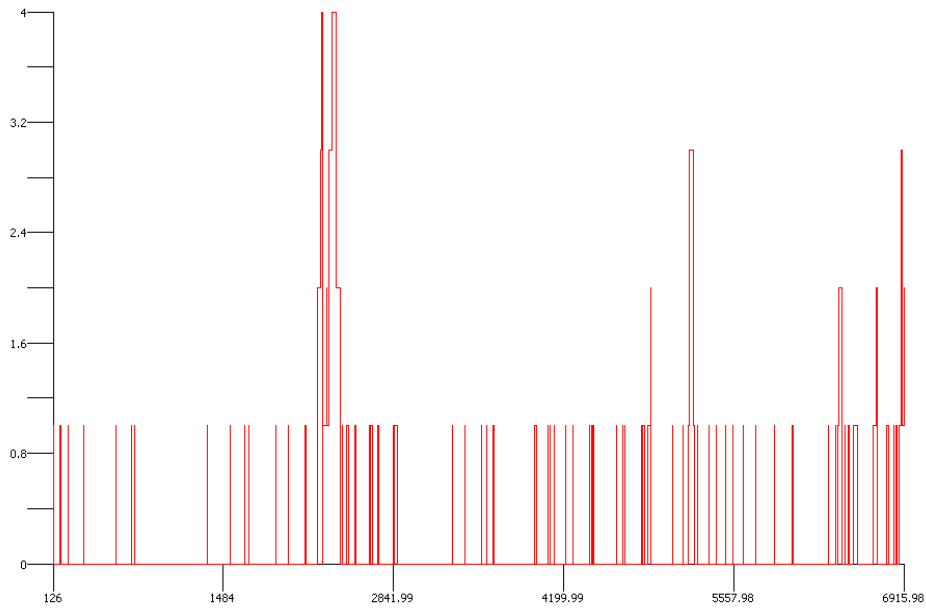

Figure 3.26: Ships at anchorage over time

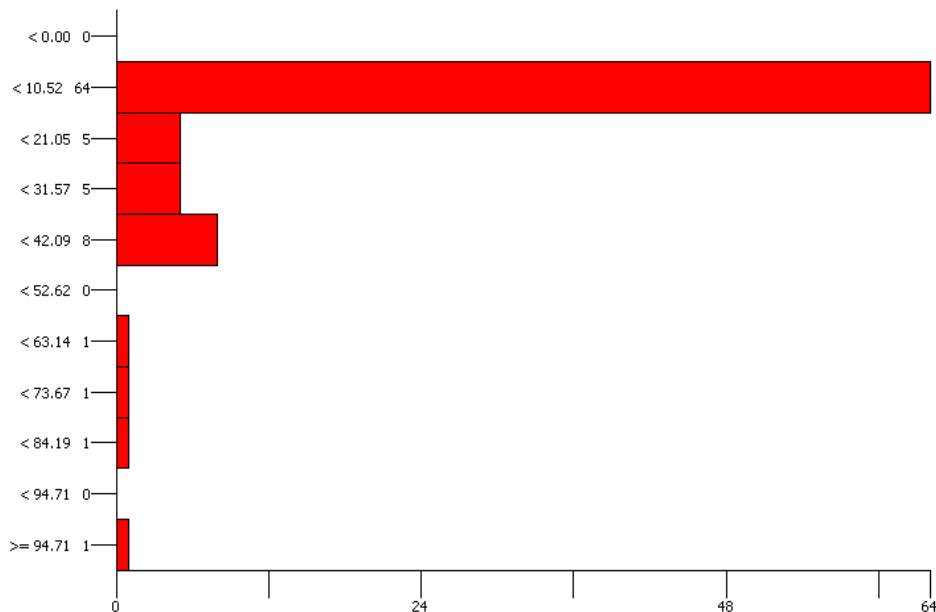

Figure 3.27: Distribution of waiting times at anchorage

The estimation of an acceptable total number of registered encounters or encounter density (see Figure 3.28, entrance to Rotterdam) per section type resulting in risk levels is not an easy matter. Port authorities are reluctant to formulate acceptable damage expectations and chances of casualties. If the risk level is too high, additional traffic rules could be considered. However, it should be realised that more traffic rules mostly lead to increased waiting times and a reduction of the service level.

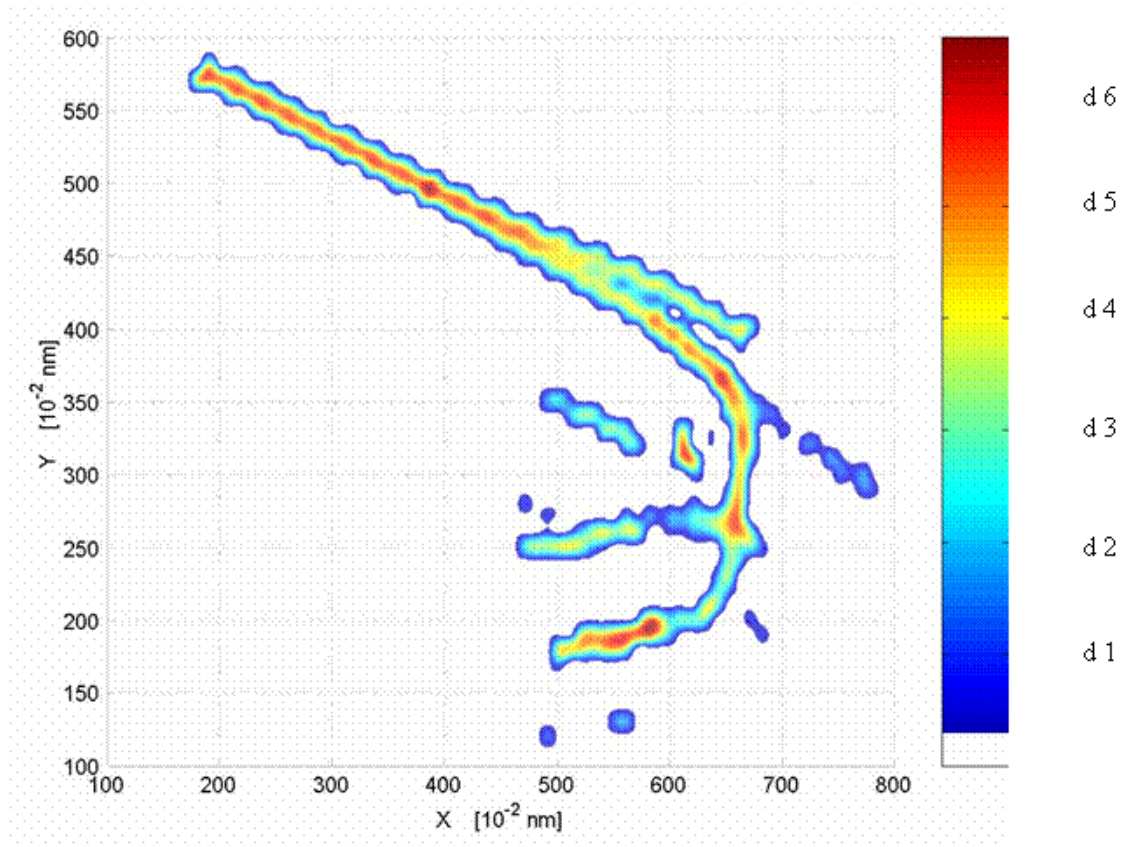

Figure 3.28: Potential encounter densities

4 OTHER ASPECTS

4.1 Risk Management and Analysis

4.1.1 General

Risk is defined as the frequency of occurrence of a negative event (accident, incident, damage) multiplied by its consequences. Risk Management is a logical and systematic method to minimise losses and maximise safety, service, operability and any other economic or social benefits of a project. It attempts to identify dangerous events and prevent them from happening, while minimising damages should they occur. This requires identifying, analysing, assessing, monitoring and communicating the risks associated with any activity, function or process associated with the project. Risk management applied to channel and harbour projects specifically focuses on incidents with vessels and their cargo.

Risk analysis is that part of the risk management process that systematically uses all available information to determine the frequency with which various incidents may occur, as well as the magnitude of their consequences. The risk, as calculated by the product of the frequency and the consequences, is compared with acceptance or rejection criteria. A decision is made whether such a risk is acceptable without any action or if mitigation measures should be taken to reduce the risk to acceptable levels. Risk analysis therefore involves the following phases:

- Set risk assessment criteria
- Identify potential incidents
- Calculate the frequency of those incidents
- Calculate the consequences of an incident
- Calculate the risk of each case analysed and calculate the cumulative risk of all cases that may occur in the project
- Compare the risk levels obtained with the assessment criteria and establish which risk is or is not acceptable
- Identify and analyse mitigation measures to correct unacceptable risks
- Specify corrective measures and incorporate them into the project and the operating regulations of the navigation and harbour project under study

The flow chart of a risk management study is shown in Figure 4.1.

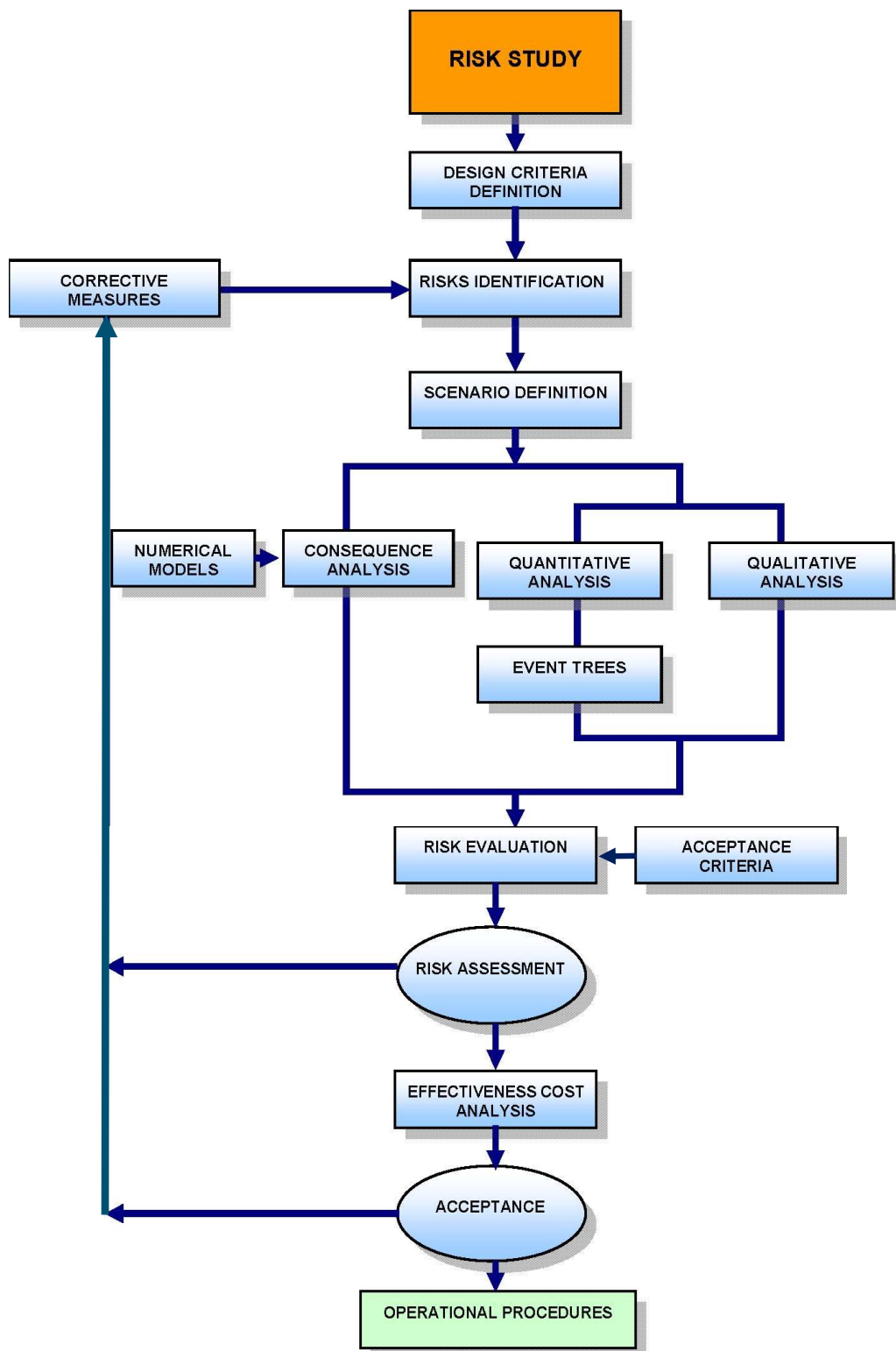

Figure 4.1: Methodology for carrying out a risk study

4.1.2 Maritime Incidents

The term ‘incident’ as related to channel navigation is defined as an event that is abnormal or does not result from the standard control of a vessel under normal operating conditions. These could, for instance, be caused by failure of the vessel’s engine or rudder, malfunctioning of tugs, breaking of tow or mooring lines, etc., as well as by extreme or exceptional environmental or working conditions. The consequences of an incident can lead to (a) deaths and injuries, (b) damage to or loss of the vessel or cargo, (c) losses and damages to other vessels, channel and harbour infrastructure or to other property and/or (d) damages to the environment or other goods.

Events in which a deliberate human action causes damage are not considered an incident. Such unlawful, terrorist and anti-social actions, for which it is difficult to make provision in channel design, are covered by the International Maritime Organisation (IMO) Regulations reflected in the SOLAS (Safety of Life at Sea) Code and in the IMO International Ship and Port Facility Security (ISPS) Code. The implementation of these codes by the IMO member states follows a specific risk analysis methodology. Of course, these deliberate human actions should be included in the operational security conditions for the port or terminal.

Incidents or cases in which an accident happens in accordance with the definition above may therefore be considered as variable events. They have a small probability of occurrence during the useful life of the channel and harbour or during any other phase that may be under analysis. However, should they occur, they may have significant effects on the safety or the service of the project.

The possibility of incidents does not normally impact the geometric design of the channel or the harbour, as is the case with operational regulations. However, the occurrence of incidents cannot be ignored and should be properly assessed. This may lead to preventive or corrective measures to mitigate their consequences, without excluding the possibility that it may be necessary to modify the geometric dimensioning to deal with such cases (e.g. options for an aborted entry manoeuvre).

The methodology to analyse and deal with such cases is the subject of risk analysis, whose basic application criteria are presented in this section. The implementation of mitigation measures resulting from a risk analysis and the continuous enforcement of actions to ensure the proper and safe functioning of the project is part of risk management. Mitigation measures should be incorporated into the operational regulations of the channel and harbour area under analysis.

4.1.3 Types of Incidents

The incidents to be analysed start with a triggering event, which is the first of a sequence of events that lead to a situation of danger, damage or failure. This sequence is known as the accident scenario. These triggering events can be classified in the following groups:

- General incidents associated with the vessel’s navigation which depend on its equipment (propulsion, propeller, rudder, etc.)
- Specific incidents depending on the type of vessel, kind of goods transported, or passengers
- Incidents involving manoeuvring and the people or means that support them (pilots, tugs, mooring lines, channel markers, leading lights, etc.)

- Incidents connected with changes in metocean conditions during the manoeuvre
- Incidents caused by third parties not involved in the operations
- Other incidents not classified under the preceding categories

4.1.4 Risk Analysis Methodologies

Risk analysis methodologies may be qualitative or quantitative, or a combination of both, depending on the circumstances. The complexity and cost of a risk analysis are greater when more extensive quantitative analyses have to be conducted. A simplified qualitative analysis may be undertaken first to obtain an overall indication of the level of risk. Subsequently, a more specific quantitative analysis can be conducted when necessary. There are two basic models that can be used to analyse risks:

- The Matrix Method analyses each of the cases individually. When the analysis is conducted using qualitative procedures, the Qualitative Matrix Method (QLM) is recommended. Similarly, when the analysis is made using quantitative methods, the Quantitative Matrix Method (QTM) is recommended
- The Overall Method is an event tree analysis (ETA) of incidents that includes analyses of all the cases and allows a joint assessment of all incidents.

The Matrix Method enables one to identify the most unfavourable cases and to deal with them according to previously established decision making rules. However, this method leads to a fragmentation into individual cases, where each individual event may be acceptable, while this may not be the case for the full set of cases.

To reduce this disadvantage of the Matrix Method, the analysis should not be fragmented into too many scenarios. The Overall Method leads to a joint assessment, thereby ensuring that the overall level of risk does not exceed the criteria. The most efficient way of assessing risks is by applying both methods. This allows defining the specific actions for individual events that contribute most to the total risk, whilst still considering the total impact and risk.

A Simplified Qualitative Matrix Method (SQM) has been developed, which can be applied in the preliminary project phases (Concept Design). This allows eliminating cases that can be rejected due to their very low level of risk, or, in the Detailed Design, cases where the safety level required are not significant. This method is illustrated in the following section.

4.1.5 Simplified Qualitative Matrix Method

The risk assessment in the Simplified Qualitative Matrix (SQM) methodology generally consists of the following actions:

- Identification of risk events and selection of the most significant accidents that might occur in the channel and other manoeuvring areas
- Assessment of risks is undertaken where the most important risk cases are assessed using a fast-time or real-time ship manoeuvring simulator, depending on the suitability for each case considered. The consequences of each case are quantified relative to safety for human life, economic impact, losses, etc.
- Analysis of the consequences of the different risk events. Once the effect of the different risk cases has been quantified, their consequences are determined

- Assessment of the different risk events through a simplified qualitative technique. This technique analyses each event with an Assessment Matrix

An example of the SQM Assessment Matrix is shown in Table 4.1. Two aspects considered in the Assessment Matrix are frequency of occurrence and severity of consequences of the risk event. For frequency of occurrence of the risk event the following qualifiers and scores for the variables are used:

- Low = Highly improbable (almost never happens)
- Medium = Possible (happens sometimes)
- High = Highly probable (happens frequently)

Similarly, for severity of the consequences of the risk event, the following definitions are used in the assessment:

- Low (L) = Assessment score between 0 and 7
- Medium (M) = Score between 8 and 11
- High (H) = Score between 12 and 15
- Very High (VH) = Score between 16 and 21

The severity score is calculated by adding up the individual scores from four impact components: safety, reputation, commercial and environmental impact. These are defined as:

- Safety = Consequences concerning people involved in work on the facilities or personnel outside the facilities who could be affected
- Reputation = Consequences concerning the perception of third parties on the owner's public image, mainly related to major events with large impact on the community
- Commercial = Consequences concerning goods within the facilities or goods or properties outside the facilities that could be affected
- Environmental = Consequences concerning leakage or polluting impacts on the local ecosystem due to the nautical operations

The range of severity scores are also shown in Table 4.1. The following individual risk scores are suggested:

Component	Score level			
	L	M	H	VH
Safety	2	3	4	6
Reputation	1	2	3	5
Commercial	1	2	3	4
Environmental impact	3	4	5	6

Finally, the SQM Risk Assessment is calculated and the following assessments are assigned for each event:

- Unacceptable (NA) = An investigation of corrective measures which will reduce the risk and classify this risk event as acceptable is required
- Correctible (C) = An investigation of corrective measures to reduce the risk 'as low as reasonably possible' (ALARP) is required
- Acceptable (A) = No need to develop corrective measures

Should the risk of any of the events analysed exceed the established criteria of acceptance, corrective measures should be proposed that will be undertaken as described in the reference regulations. An analysis and assessment of the risk of these corrective measures should be made following the same methodology as presented above. It should be determined whether the acceptance criteria can be fulfilled by adopting the corrective measures. Should several solutions be acceptable, the most suitable will be recommended based on the following considerations:

- Cost/benefit ratio of the measure
- Operational repercussions
- Generic risks for the whole area

Risk = Consequences x Frequency

Severity of Consequence	Severity Level	Severity Score Range	Frequency of Occurrence		
			Low (Highly improbable)	Medium (Possible)	High (Highly probable)
	Low (L)	0 - 7	A	C	C
	Medium (M)	8 - 11	C	C	NA
	High (H)	12 - 15	C	NA	NA
	Very High (VH)	12 - 21	NA	NA	NA

Table 4.1: Risk Assessment Matrix

4.2 Training

To ensure compliance with international, national and local regulations and best practice recommendations, consideration needs to be given to additional training requirements of personnel associated with the use of the waterway. In particular harbour masters, pilots, VTS operators and tug skippers should be included. This is especially relevant where the channel is a new construction or where a development significantly changes the previous conditions and design.

Areas of training to be considered may include:

- Requirements of new traffic management regulations arising from a risk assessment
- Navigation and manoeuvring methodology for new ship types and equipment
- Use of escort towage techniques
- Implications of minimal under keel clearance, knowledge of revised bathymetry and buoy patterns, etc.

The training benefits of simulation trials during detailed design stages should not be overlooked. A specific benefit for the quality of the design is that comments from the mariners during simulations can be solicited, recorded and incorporated in the design. The training of mariners could be added to a continuous training programme for the harbour pilots. A benefit of involving local pilots in a navigation simulation study is that they will have familiarity with the new channel operations once they are operational. An

education programme for other channel users should also be considered. Finally, training in emergency procedures due to failures of ship or tug equipment is also recommended.

4.3 Operational Rules and Environmental Limits

4.3.1 General

The maritime and environmental conditions for the various aspects of manoeuvring in a port or terminal have a direct impact on the design and operation of channels and other navigation areas. These conditions may be different for different types of vessels and for the particular conditions of every project. This section provides guidance on the limiting environmental conditions for vessel manoeuvring in channels and other areas of a port. If the specified limits are not confirmed by local experience, their suitability for the specific case must be carefully checked with maritime experts. The establishment of these limits has significant consequences for the operational downtime and profitability of the port or terminal. The finally adopted limits must be explicitly shown in the Operating Rules for the pilots, port or terminal.

Unless limiting operational conditions are already specified, the following general considerations may be applied:

- For design, it is conservatively assumed that the different environmental limits act simultaneously. However, if it can be proven that this would be unrealistic, combinations of less extreme values could be used, taking each of the environmental variables at its maximum with the other variables at their associated maxima. Such combinations will lead to different design conditions
- For operability, vessel manoeuvres will be suspended as soon as one of the environmental conditions reaches or exceeds its limits, independent of whether the remaining variables reach their limits. The possibility of operations under conditions where one limit is exceeded while the other limits are not exceeded is limited to cases where a detailed study has been carried out for the specific site.

4.3.2 Channels

The limits for navigation conditions in channels are recommended to be selected such that the drift angle β does not exceed the values specified in Table 4.2 and the vessel is sailing at the lowest permissible transit speed (see also Section 3.1.8). The channel conditions are distinguished for a range of relative depth ratios h/T , where h is the water depth and T is the vessel's draught.

The drift angle β is calculated assuming that its sine is the sum of the sines of the drift angles for the different forces act separately, i.e.:

$$\sin \beta = (\sin \beta)_{\text{wind}} + (\sin \beta)_{\text{currents}} + (\sin \beta)_{\text{waves}} + (\sin \beta)_{\text{tugs}} \quad (4-1)$$

This sum is algebraic and therefore each drift angle is considered with its pertinent plus or minus sign related to the direction of the specific action.

Channel Relative Depth Condition	β (deg)
Channels in areas with $h/T \leq 1.2$:	
• normal stretches	5
• singular points	10
Channels in areas with $1.2 < h/T < 1.5$:	
• normal stretches	10
• singular points	15
Channels in areas with $h/T \geq 5.0$:	
• normal stretches	15
• singular points	20

Table 4.2: Drift angle β versus channel relative depth

If there are no specific criteria for the minimum vessel speed V_s , this can be taken as the smallest one of the values specified in Table 4.3:

Navigation Area	Vessel speed V_s	
	m/s	knots
Outer areas:		
• Channel lanes		
▪ Long ($\geq 50 L_{pp}$)	4 - 7.5	8 - 15
▪ Short ($< 50 L_{pp}$)	4 - 6	8 - 12
• Anchorage	1 - 1.5	2 - 3
• Manoeuvring area	2 - 3	4 - 6
• Jetty area	1 - 1.5	2 - 3
Passing harbour entrances:	2 - 4	4 - 8
Inner harbour areas:		
• Anchorage	1 - 1.5	2 - 3
• Channel	3 - 5	6 - 10
• Manoeuvring area	2 - 3	4 - 6
• Piers and berthing approach	1 - 1.5	2 - 3

Table 4.3: Vessel speed range in navigation areas

4.3.3 Harbour Entrances

Vessel manoeuvrability for passing through a harbour entrance cannot be considered in isolation. The stretch of channel from the outer and inner limits must be considered. The following aspects have to be taken into consideration:

- The outer stretch of the entrance is a channel with a completely defined alignment. Although this stretch is recommended to be straight, it will often be necessary to include a curved leg. It may also be possible to navigate outside the harbour using different approach routes
- The approach routes are pre-set and are not at all times aligned with the wind, waves or currents. Therefore, major cross-component forces and drift angles close to the maximum values admissible must be considered in the design. Environmental limits have to be determined as a function of the required service level. Unless specific measurements or model results are available, the following transverse or lateral environmental conditions are recommended (see also 3.1.8.2):

- Wind speed $V_{W,1 \text{ min}} \leq 15 \text{ m/s (29 knots)}$
 - Current speed $V_{F,1 \text{ min}} \leq 1.00 \text{ m/s (2 knots)}$
 - Wave height $H_s \leq 3.0 \text{ m}$
- In small-craft ports of refuge (for fishing and pleasure boats), as well as in ports designed to operate under severe environmental conditions, approach routes may allow the ships/boats to arrive at the harbour with their stern into the storm or at a small angle with the channel (called sailing with the storm on a quarter), with angles of 15° to 20° between the route and the wave direction
 - The limiting in-line environmental conditions for these storm entry routes can be established by analysing the service levels required and, if criteria are not yet available, by the following operational limits:
 - $V_{W,1 \text{ min}} \leq 16 \text{ m/s (32 knots)}$
 - $V_{F,1 \text{ min}} \leq 2.00 \text{ m/s (4 knots)}$
 - $H_s \leq 5.0 \text{ m}$

In this and subsequent paragraphs the following symbols are used:

- $V_{W,1 \text{ min}}$ = Wind velocity at a height of 10 m above sea level, as a 1-minute average
- $V_{F,1 \text{ min}}$ = Current velocity at a depth of half the vessel's draught, as a 1-minute average
- H_s = Significant wave height.

4.3.4 Stopping Areas

The operational criteria for stopping areas are the same as for the adjacent (i.e. connecting) channel area. If the stopping area will not be in line with the channel, the direction of the different actions on the ship will be different from those in the channel. In this case, the limiting operating conditions should conservatively be assumed as omnidirectional.

In some cases, the configuration of the port or manoeuvring area does not allow the vessel's stopping manoeuvre to be carried out from beginning to end in a controlled manner. In such a case, the vessel's stopping area has to be located outside the harbour or site under consideration, so that the vessel will come to a stop before entering the harbour or site area. The vessel can then proceed to perform this final turning or approaching manoeuvre to the quays with tug assistance. In this case, the limiting operational environmental conditions may have to be based on the limitations of the auxiliary vessels (pilot boat, tugs), which will guide the vessel towards its berth. Unless detailed model results for each area are available, the limiting operating environmental conditions may be set at the following values:

- $V_{W,1 \text{ min}} \leq 10 \text{ m/s (20 knots)}$
- $V_{F,1 \text{ min}} \leq 1.00 \text{ m/s (2 knots)}$
- $H_s \leq 2.0 \text{ m}$

Again, these conditions are assumed to be omnidirectional.

4.3.5 Turning Areas

The operational limits come from the resulting environmental forces on the ship and the drift angles due to these forces. In such cases the following operational limits are recommended:

Manoeuvres without tug assistance:

- $V_{W,1 min}$ ≤ 10 m/s (20 knots)
- $V_{F,1 min}$ ≤ 0.50 m/s (1 knot)
- H_s ≤ 2.0 m / 3.0 m (depending on the type of manoeuvre)

Manoeuvres with tug assistance:

- $V_{W,1 min}$ ≤ 10 m/s (20 knots)
- $V_{F,1 min}$ ≤ 0.10 m/s (0.2 knots)
- H_s ≤ 1.5 m / 2.0 m (depending on the type of tugs)

When manoeuvring areas are located in zones with no geometrical restriction in one direction (e.g. in some river ports), the operational limits in the longitudinal direction (river) can be higher, in accordance with the particular conditions of the project.

4.3.6 Anchorage Areas

The environmental conditions for the operational limits in the anchorage area are listed below. They depend on the vessel, type of anchorage and the scheduled operation. Wind speed is determined for general-type vessels. Should they have relatively large exposure areas (methane carriers, container ships, car carriers, in-ballast oil tankers, etc.), the limiting operational wind speeds shall be 20 % less than those given in Table 4.4.

Activity	$V_{W,1 min}$	$V_{F,1 min}$	H_s
Approach and mooring manoeuvres	17 m/s	2 m/s	2.5 m
Vessel at anchorage			
• With one anchor ahead	24 m/s	2 m/s	3.5 m
• With two anchors down (anchoring against ebb/flood with anchor ahead and astern)	30 m/s	2 m/s	4.5 m
• Longitudinal forces	24 m/s	2 m/s	3.5 m
• Transverse forces	Anchorage not operative		
Loading and unloading operations	Depend on (un)loading equipment		

Table 4.4: Limiting operational wind speeds

4.3.7 Moorings Areas and Buoy Systems

The environmental conditions recommended as operational limits for mooring areas and buoy systems are shown in Table 4.5. These depend on whether the vessel is able to freely rotate to an orientation with the minimum resistance or whether its orientation is fixed.

Activity	Mooring area with free orientation			Mooring area with fixed orientation ²
	Mooring to single buoys	Mooring to mini single buoys ¹	Mooring to single dolphins	
Approach and mooring				
• $V_{W,1 min}$	17 m/s	17 m/s	17 m/s	10 m/s
• $V_{F,1 min}$	2.00 m/s	2.00 m/s	2.00 m/s	0.50 m/s
• H_s	2.5 m	2.0 m	2.5 m	2.0 m
Vessel at anchorage				
• $V_{W,1 min}$	30 m/s	24 m/s	30 m/s	30, 22 m/s
• $V_{F,1 min}$	2.00 m/s	2.00 m/s	2.00 m/s	2.0, 1.0 m/s
• H_s	4.5 m	2.0 m	3.5 m	3.0, 2.0 m
Notes:				
1. Mooring to mini-single buoys or small buoys usually occurs with fishing and pleasure boats				
2. Mooring area with fixed orientation usually means buoy systems, etc.				
3. The first figure in this column is for longitudinal forces and the second for transverse forces on the vessel				

Table 4.5: Operational limits for mooring areas and buoy systems

4.3.8 Basins and Quays

The limiting operational conditions for navigating and manoeuvring vessels (including stopping and turning) when performed inside basins and near quays are the same as those established for these manoeuvres in other harbour areas. This is irrespective of the fact that the more sheltered location of basins will usually cause a lower percentage of downtime.

Three conditions must be considered as specific quay conditions:

- Vessels berthing
- Loading and unloading operations
- Vessels moored at quays and jetties

The limiting environmental conditions for these three conditions depend on other factors besides the vessel. Vessel berthing limits depend on the available tugs and the fender system at the quay. Stoppage of loading and unloading operations will mainly depend on the characteristics of the cargo and the (un)loading equipment used. Limits for vessels staying at quays and jetties depend on the design limits of the structure, on the availability of towing equipment to take the vessels off the berth under extreme conditions and on the capability of the vessel to navigate in a controlled manner to other quays, anchorages or outer navigating areas. Other considerations and factors may also play a role in some cases, such as the comfort limits for passengers on a cruise ship under wave action.

The limiting environmental operating conditions listed in Table 4.6 are likely maximum values for quays and jetties, but more site specific values may be used, e.g. the evaluation of downtime percentages resulting for different cases and associated investments necessary to guarantee operability under the limiting conditions.

Description	$V_{W,1 min}$	$V_{F,1 min}$	H_s
1. Vessel berthing			
• Forces longitudinal to the quay	17.0 m/s	1.0 m/s	2.0 m
• Forces transverse to the quay	10.0 m/s	0.1 m/s	1.5 m
2. Loading and unloading operation stoppage (conventional equipment)			
• Forces longitudinal to the quay			
– Oil tankers			
< 30,000 DWT	22 m/s	1.5 m/s	1.5 m
30,000 DWT – 200,000 DWT	22 m/s	1.5 m/s	2.0 m
> 200,000 DWT	22 m/s	1.5 m/s	2.5 m
– Bulk carriers			
Loading	22 m/s	1.5 m/s	1.5 m
Unloading	22 m/s	1.5 m/s	1.0 m
– Liquid Gas Carriers			
< 60,000 m ³	22 m/s	1.5 m/s	1.2 m
> 60,000 m ³	22 m/s	1.5 m/s	1.5 m
– General cargo merchant ships, deep sea fishing boats and refrigerated vessels	22 m/s	1.5 m/s	1.0 m
– Container ships, RoRo ships and ferries	22 m/s	1.5 m/s	0.5 m
– Liners and Cruise ships ¹	22 m/s	1.5 m/s	0.5 m
– Fishing boats	22 m/s	1.5 m/s	0.6 m
• Forces transverse to the quay			
– Oil tankers			
< 30,000 DWT	20 m/s	0.7 m/s	1.0 m
30,000 DWT – 200,000 DWT	20 m/s	0.7 m/s	1.2 m
> 200,000 DWT	20 m/s	0.7 m/s	1.5 m
– Bulk carriers			
Loading	22 m/s	0.7 m/s	1.0 m
Unloading	22 m/s	0.7 m/s	0.8 m
– Liquid Gas Carriers			
< 60,000 m ³	16 m/s	0.5 m/s	0,8 m
> 60,000 m ³	16 m/s	0.5 m/s	1.0 m
– General cargo merchant ships, deep sea fishing boats and refrigerated vessels	22 m/s	0.7 m/s	0.8 m
– Container ships, RoRo ships and ferries	22 m/s	0.5 m/s	0.3 m
– Liners and Cruise ships ¹	22 m/s	0.7 m/s	0.3 m
– Fishing boats	22 m/s	0.7 m/s	0.4 m
3. Vessel at quay			
• Oil tankers and Liquid Gas Carriers			
– Actions longitudinal to the quay	30 m/s	2.0 m/s	3.0 m
– Actions transverse to the quay	25 m/s	1.0 m/s	2.0 m
• Liners and Cruise ships ²			
– Actions longitudinal to the quay	22 m/s	1.5 m/s	1.0 m
– Actions transverse to the quay	22 m/s	0.7 m/s	0.7 m
• Recreational boats ²	22 m/s	1.5 m/s	0.4 m
– Actions longitudinal to the quay	22 m/s	1.5 m/s	0.4 m
– Actions transverse to the quay	22 m/s	0.7 m/s	0.2 m
• Other types of vessel	Limitations imposed by the design loads		
Notes:	1. Conditions relative to passengers embarking or disembarking. 2. Conditions relative to the limits for passenger's comfort on board. 3. Longitudinal = wind, current or waves taken as acting longitudinally when their direction lies in the sector of $\pm 45^\circ$ relative to the vessel's longitudinal axis. 4. Transverse = wind, current or waves taken as acting transversally when their direction lies in the sector of $\pm 45^\circ$ relative to the vessel's transverse axis.		

Table 4.6: Limiting environmental operating conditions at quays and jetties

4.4 Winter Navigation and Channel Design

4.4.1 General

As a rule, the general guidelines and dimensioning criteria for channel design apply to the design of winter channels as well. Thus, the basic dimensions of winter channels are selected with respect to the ice-free conditions in the channel, but the special demands of winter navigation need to be taken into account for each channel individually along with other factors affecting design and dimensioning.

Winter navigation is defined in this report as shipping that takes place in winter conditions when the sea is wholly or partly covered by ice. Some ships, which are strengthened for navigation in ice, can proceed without icebreaker assistance in light ice conditions, but others need icebreaker assistance. When channels are opened by an icebreaker, ships are either towed or proceed under their own engines.

For a channel to be considered as a so-called winter channel, it needs a depth that enables icebreakers to operate safely. It also needs markings and buoys which are reliable in winter. In choosing different types of design ships for dimensioning, icebreakers may be an option.

The questions relative to winter navigation are best considered at an early design phase because in some cases they may have a notable effect on the project. Winter conditions may also affect project schedules as well as channel implementation and maintenance costs.

4.4.2 Factors Affecting the Design of a Channel for Winter Navigation

Factors affecting the design of channels for winter navigation include (a) general conditions, (b) alignment and geometry, (c) channel width, (d) channel depth and under keel clearance, (e) channel markings and AtoN, (f) harbour basin and (g) pilotage. Each of these is discussed below.

4.4.2.1 General Conditions

- The primary task in designing winter channels is to study ice and winter navigation conditions of the relevant areas. Useful sources of information include ice charts, statistical surveys, icebreaker crews, local pilots, ship crews and shipping companies and port authorities.

4.4.2.2 Alignment and Geometry

- Difficult areas, such as areas with drift ice and/or ridges, should be avoided.
- The route chosen should be as sheltered as possible
- Narrows where ridges may form should be avoided (difficult to circumvent)
- Alternative (parallel) tracks should be created, e.g. for icebreakers to circumvent ships beset in narrow passages
- Ships' turning manoeuvres may be hampered by ice. Large turning angles and small bend radii should be avoided in difficult areas

4.4.2.3 Channel Width

- The channel width is primarily determined by the design ship in ice-free conditions. Additional factors generated by ice conditions are evaluated separately
- In open approaches where drift ice and ridges occur, the channel should be as wide as possible so that alternative tracks can be used to circumvent ridges (Figure 4.2)
- In difficult areas the channel should be at least wide enough to enable the icebreaker to pass alongside the ship beset in ice in order to 'cut it out'. Minimum width should meet dimensioning criteria of a normal one-way channel
- There should be supplementary areas for icebreaker operations (i.e. turning manoeuvres, overtaking and passing), especially along one-way channels. Wherever possible, the channel should be as wide as a two-way channel

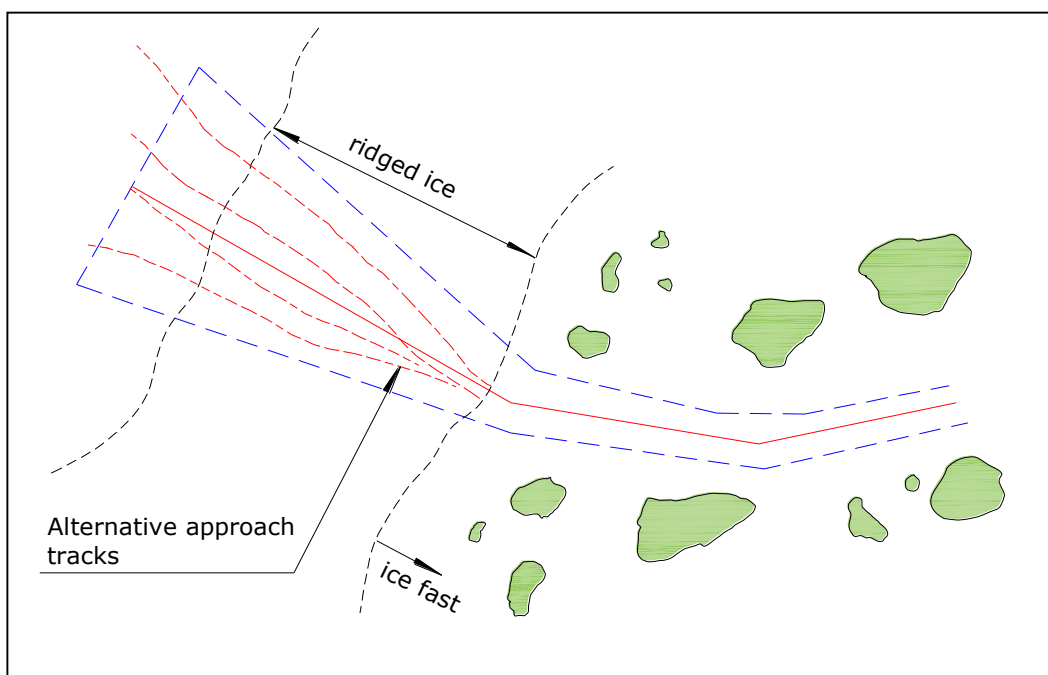

Figure 4.2: Outer reaches of channel should be wide enough to enable alternative approach tracks required by varying ice conditions
(Note: ice fast = solid ice)

4.4.2.4 Channel Depth, Gross Underkeel Clearance

- The channel depth and gross under keel clearance are primarily determined by the design vessel in ice-free conditions
- If the draught of the icebreaker is deeper or close to the draught of the design vessel, the gross under keel clearance required by the icebreaker should be taken into account in dimensioning the channel depth
- It should be noted that vertical movements of icebreakers differ from the behaviour of conventional merchant ships. For instance, the trim (trim angle) may be bigger than usual because of rapid and extreme changes using machinery power
- Tracks for overtaking and reserve channels intended for winter navigation should be deep enough for icebreakers.

4.4.2.5 Channel Markings/Aids to Navigation

- The philosophy of channel marking is basically the same in all channels (beacons, edge marks)
- Winter conditions and winter navigation place special demands on the stability, strength, visibility, durability and reliability of navigation aids (both on structures and equipment). Especially in areas with drift ice, there should be a sufficient number of fixed markings (edge marks, radar marks and leading beacons)
- Buoys and spar buoys may, due to the impact of ice, be removed from their positions or submerged in areas with no drift ice. Therefore, the marking of a winter channel should be such that navigators may rely entirely on fixed beacons
- Heavy ice buoys should be used as buoys, as they are more resistant to the impact of ice than light spar buoys
- Maintenance characteristics of aids to navigation in winter conditions must be taken into account

4.4.2.6 Harbour Basin

- Ship manoeuvres are hampered by ice and sludge. Consequently, the manoeuvring basin should be larger than required minimum dimensions in open water
- Sufficient space/water should be provided in the harbour area beyond the harbour and quay basins to accommodate compacting ice
- The needs and possibilities of icebreakers to operate in the harbour area should be studied
- The effects of harbour constructions (e.g. piers) on the movement and compacting of ice should be taken into account during design. Both their layout and structure need to be carefully considered

4.4.2.7 Pilotage

- The pilot boarding place should be located in a place where boarding and disembarking is possible in winter conditions.

4.5 Environmental Issues

The design and building of a new navigation channel or the modification of an existing channel have many strong relations to environmental issues, especially linked to dredging, blasting operations and maintenance dredging. These issues are strongly related to hydrological (tidal) effects, sedimentological impacts and effects on all biological chains.

Many PIANC reports deal with dredging and the environment and it is best to refer directly to those reports. Some examples include EnviCom WG 4 report – ‘Environmental Management Framework for Ports and Related Industries’ (1999), EnviCom WG 8 report – ‘Biological Assessment Guidance for Dredged Material’ (2006), EnviCom WG 10 report – ‘Environmental Risk Assessment of Dredging and Disposal Operations’ (2006), EnviCom WG 104 – ‘Dredging Material as a Resource’ (2009) and EnviCom WG 100 report – ‘Dredging Management Practices for the Environment – A Structured Selection Approach’ (2009).

4.5.1 Regulations and Sustainability

The maritime sector is by its very nature international and its functioning depends strongly on the international regulatory framework that has developed over the years. This regulatory framework is intended to provide a level playing field to maritime operators all over the world. The minimum standards provided in these regulations are an important driver for raising awareness and consideration of the different forms of environmental pressure that are associated with maritime activities.

The regulatory framework for sustainability issues in the maritime sector has become very complex and consists of a large number of regulations that have evolved with different forms of shipping. This basic framework is complemented, in some parts of the world, by additional national or international regulations.

For instance, the Environmental, Health and Safety (EHS) Guidelines issued by the IFC (International Finance Corporation) are technical reference documents with general and industry-specific examples of good international industry practice.

In all countries, there is an obligation to perform an 'Environmental Impact Assessment' (EIA) during planning of any type of important work. According to international legislation and especially the EU (European Union) Council Directive 85/337/EEC on the assessment of the effects of certain public and private projects on the environment, the environmental impact assessment shall identify, describe and assess in an appropriate manner, in the light of each individual case, the direct and indirect effects of a project on the following factors:

- Human beings, fauna and flora
- Soil, water, air, climate and the landscape
- Material assets and the cultural heritage
- Interaction between the factors mentioned above

The structure of an EIA is in all national and international legislations as follows:

- Define initial state of the environment at the site where the project will take place
- Complete analysis of all project impacts (temporary and permanent, direct and indirect)
- List reasons why the project was chosen, especially for environmental concern
- Describe mitigation measures considered to suppress, minimise and compensate the effect on environment and cost estimate of those measures

According to results of the EIA, mitigation of habitat losses through compensatory measures has long been applied when avoidance, minimisation and rectification of impacts were not feasible. Off-site restoration, enhancement and construction of wetlands and other habitats have been the most frequent compensations. The discussions around these compensatory measures are often very contentious among the stakeholders and can easily lead to long delays for some projects.

In 2008 PIANC proposed a new position paper to enable better environmental integration and social acceptance of projects called 'Working with Nature'. Working with Nature is about more than avoiding or mitigating the environmental impacts of a pre-defined design. Rather, it sets out to identify ways of achieving the project objectives by working with natural processes to deliver environmental protection, restoration or enhancement outcomes.

Fundamentally, Working with Nature means doing things in a different order:

- Establish project need and objectives
- Understand the environment
- Make meaningful use of stakeholder engagement to identify possible win-win opportunities
- Prepare initial project proposals/design to benefit navigation and nature

Working with Nature thus requires a subtle but important evolution in the way project development is approached.

4.5.2 Work on Channels and Dredged Materials Management

Construction and maintenance dredging and dredged material disposal may impact habitats and pose a significant hazard to human health and the environment, particularly if the sediments are contaminated. As part of a Marine Dredging Management Plan, the following recommendations should be adopted to avoid, minimise, or control impacts from dredged materials.

4.5.2.1 Dredge Planning Activities

Dredging should only be conducted if necessary and based on an assessment of the real need for new infrastructure components or port navigation access to create or maintain safe navigations channels.

Prior to initiation of dredging activities, dredge materials should be evaluated for their physical, chemical, biological and engineering properties to determine their suitability for reuse or disposal options. This will be an important part of the EIA.

4.5.2.2 Dredging

Excavation and dredging methods should be selected to minimise suspension of sediments, minimise destruction of benthic habitat, increase the accuracy of the operation and maintain the density of the dredge material, especially if the dredge material includes contaminated materials.

Areas sensitive for marine life such as feeding, breeding, calving, and spawning areas should be identified. Where sensitive species are present, dredging (and blasting) should be conducted in a manner so as to avoid fish migration or spawning seasons, routes and grounds.

Use techniques (e.g. silt curtains) to minimise adverse impacts on aquatic life from the re-suspension of sediments.

Inspection and monitoring of dredging activities should be conducted to evaluate the effectiveness of impact prevention strategies and re-adjusted where necessary.

4.5.2.3 Disposal of Dredged Material

Dredged material should be analysed to select appropriate disposal options (e.g. land reclamation, open water discharge or contained disposal). Beneficial reuse of uncontaminated, dredged material should be considered as a use for compensatory

measures (e.g. for wetland creation or enhancements, habitat restoration, or creation of public access/recreational facilities).

Use of submerged discharges should be considered for hydraulic disposal of dredged material.

Use of lateral containment in open water disposal should be considered. Use of borrow pits or dykes reduces the spread of sediments and effects on benthic organisms.

Confined disposal facilities should be used, either near-shore or upland, when open water disposal is not feasible or desirable. If dredge material is contaminated, confined disposal facilities should include liners or other hydraulic containment design options to prevent leaching of contaminants into adjacent surface or groundwater bodies. Treatment of dewatering liquids (e.g. metals and persistent organic pollutants) may be required prior to discharge. Site-specific discharge quality standards should be established depending on the type and toxicity of the effluents and the discharge location.

4.5.3 Biodiversity

Construction and maintenance dredging; disposal of dredge material; construction of piers, wharves, breakwaters and other water-side structures; and erosion may lead to short and long-term impacts on aquatic and shoreline habitats. Direct impacts may include the physical removal or covering of sea floor, shore, or land-side habitat, in addition to changes to water flow patterns and related sedimentation rates and patterns. Indirect impacts may result from changes to water quality from sediment suspension or discharges of storm water and wastewater.

Potential impacts to shoreline vegetation, wetlands, coral reefs, fisheries, bird life and other sensitive aquatic and near-shore habitats during port construction and operation should be fully assessed with special consideration for areas of high biodiversity or those required for the survival of *critically endangered* or *endangered* flora and fauna. The depth of the port should be considered in the design phase in terms of habitat destruction and the amount and nature of dredging required.

Additionally, specific prevention and mitigation measures should be adopted for blasting activities, which can cause considerable impacts to marine organisms and their habitats during construction.

4.6 Aids to Navigation (AtoN)

Guidelines and recommendations for Aids to Navigation (AtoN) are agreed internationally and published by IALA (2010). This section discusses AtoN positioning systems and facilities in the context of the planning and design of approach channels, but does not take precedence over specific IALA recommendations. Navigation itself may be understood as monitoring one's position geographically within a constrained waterway. There are several navigation methods widely used in the maritime world:

- Visual navigation that uses optical observations
- Radar navigation that uses radar observations
- Electronic navigation that uses positioning signals from satellites and other systems
- Celestial navigation

Today, all are generally used in combination as appropriate. Also, VTS/VTMS (Vessel Traffic Service) systems are monitoring and assisting safe navigation from shore via radio in many port and coastal areas.

Aids to Navigation are needed where there is a lack of adequate natural visual leads. They are of four basic types:

- Directional guidance, i.e. lateral positioning reference in a channel
- Longitudinal positioning reference to a channel
- Acting as a fixed point while navigating, i.e. position reference
- Warning of possible hazardous areas and objects

Further information on AtoN can be obtained in IALA (2010), USACE (U.S. Army Corps of Engineers 2006), and ROM (2003).

4.6.1 Channel Markings

Channel markings are prescribed for both visual and radar navigation. Channel markings may be located either along the sideline of the channel e.g. buoys or channel centre line, e.g. leading lights. The properties of markings may be summarised as:

- Leading lines along centre lines act as a very powerful tool for lateral positioning, but poor for longitudinal positioning
- Leading lines crossing the channel are accurate tools for longitudinal positioning
- Single markers are mainly for longitudinal positioning, but may be effective for lateral positioning when used in long, wide channels
- Paired markers act for both longitudinal and lateral positioning. Alternatively, centre line markers may be used
- Single marker on a curve turning point may act as position reference around the turn
- Single marker may be used for warning purposes. For example, warning about a hazardous wreck or a rock

By combining types of markings, one may design a channel that is safe to navigate. The required AtoN are related to channel properties, including width and curvature, weather and traffic conditions.

There is a very strong connection between channel dimensions, alignment and markings. A curvy channel needs good lateral and longitudinal positioning and all the curves should have turning point reference or some other provision.

Theoretically, the more channel markings provided, the easier it is to navigate. However, there is a saturation point where adding AtoN does not help positioning further. One has to appreciate that too many markers may be confusing. Also lateral marks themselves effectively narrow the channel. The task is to find the optimal solution between channel marking and channel dimensions. Usually, this point has to be found by simulations in the detailed design phase. Because ships use a variety of AtoN in addition to channel markings the designer should pay attention to possible channel crossings to avoid creating confusing navigational situations with too many marks.

A minimum requirement of channel marking is that at least one marker should always be visible (by eye or radar) on either side of the channel [USACE, 2010]. With this rule and knowledge of visibility conditions in area of interest, one can calculate maximum

distances between markers. Maximum marker spacing is then less than minimum visibility required. The ship size, speed, bridge visibility and the use of electronic navigational aids may dictate that the minimum distance required is smaller than the minimum meteorological distance considered.

One possible way to mark a channel is to place a marker in all vertices of sidelines ('corners'). If straight parts are longer than the maximum spacing allowed, there is always an option to place additional markers along the straight sideline. This marking technique is common in curved channels. An alternative to both straight and curved channels is the use of centre line buoys, particularly in two way channels. Fewer buoys are needed and the factor of paired buoys creating additional channel obstructions and small craft restrictions is avoided.

In simulation studies, it has been shown that gated markers are superior in straight parts of channel compared to single markers on sideline vertices [USACE, 2010]. As mentioned earlier, paired markers are effective for both lateral and longitudinal positioning.

In summary, every channel is an individual case and should be studied as such. There is no universal optimal solution, but a variety of marking solutions and techniques. The proposed marking systems should always be studied in simulation, at least on their critical points. Designers should always consult an AtoN expert while planning the AtoN equipment of a channel.

4.6.2 On-Board Navigation Systems

The basic goals of an on-board navigation system are to recognise and monitor both the vessel's absolute geographical position within the area and the vessel's relative position to known fixed and moving objects, both natural and man-made.

4.6.2.1 Visual Navigation

The primary means of visual navigation is manually plotting on a paper chart using two or more compass bearings of geographical features. The use of horizontal and vertical sextant angles, etc. can be considered impractical and obsolete. Relative position fixing can be facilitated through the observation of various forms of leading marks, including geographical features and channel buoys. Night vision equipment and binoculars are probably the only optical aids that may be found in use today.

4.6.2.2 Electronic Aids

Electronic aids include radar, ECS, ECDIS, GNSS, DGPS, eLORAN, e-Navigation, AIS, PPU and miscellaneous systems. Each of these systems and instruments is described below. The designer shall always keep in mind that systems mentioned here are not available all the time and for all vessels. Therefore, if necessary, it should be possible to navigate without this equipment.

Radar can be used for both geographical position-fixing and for relative position monitoring through a variety of techniques. Radar technology continues to develop. For channel marking, the addition of radar beacons or Racons can significantly improve the visibility of important buoys, etc.

ECS is a non-IMO approved navigation information system that electronically displays vessel position and relevant nautical chart data and information from an ECS Database on a display screen.

ECDIS (Electronic Chart Display and Information System) equipment is specified in the IMO ECDIS Performance Standards and with adequate back up arrangements can be accepted as complying with the up-to-date chart required by regulation V/19 & V/27 of the 1974 SOLAS Convention.

GNSS (Global Navigation Satellite System) is the standard generic term for satellite navigation systems.

DGPS (Differential GPS) is an enhancement to GPS; the result is a significantly more accurate and reliable position fix.

eLORAN (Enhanced LOnG-RAnge Navigation system) is an independent, dissimilar complement to GNSS. The international maritime community now understands that its future digital e-Navigation environment needs an internationally agreed alternative system to GNSS. eLORAN is the only viable candidate.

e-Navigation (electronic Navigation) whilst not strictly a position-fixing system, is a navigational concept which will have far reaching influences on the future of shipboard navigation systems and techniques. It is an IMO-led concept based on the harmonisation of marine navigation systems and supporting shore services driven by user needs.

AIS (Automatic Identification System) is a system used by ships and Vessel Traffic Services (VTS, see section 4.6.3) principally for identification and locating vessels. Work is now ongoing to facilitate the transmission of data such as identification, meteorological and tides from navigation marks via AIS.

PPU (Portable Pilot Unit) is a notebook computer-based system which, depending on its level of sophistication and manufacturer, is able to provide the Pilot with his own wholly or partially independent navigation and manoeuvring monitoring console.

Miscellaneous systems are more fundamental equipment that are also in use and include but not limited to Gyro, Magnetic, Fluxgate and GPS-based compasses, Echo sounders and sonar devices, etc. Additionally, there are numerous docking aid systems. There is also a wide range of newly developed AtoN (section 4.6.4).

4.6.3 VTS/VTMS Systems and Impact

Vessel Traffic Services (VTS), often referred to as VTMS (Vessel Traffic Management System), are shore-based port or coastal region traffic management systems. The types of service range from the provision of information to ships, to extensive management of traffic within a port or waterway.

The following text is the IMO definition of VTS (IMO Resolution A857 (20)):

- Vessel Traffic Service (VTS) – a service implemented by a competent authority, designed to improve the safety and efficiency of vessel traffic and to protect the environment. The service should have the capability to interact with traffic and respond to traffic situations developing in the VTS area.

VTS should comprise at least an information service and may also include others, such as a navigational assistance service or a traffic organisation service, or both, defined as follows:

- An information service is a service to ensure that essential information becomes available in time for on-board navigational decision making
- A navigational assistance service is a service to assist on-board navigational decision making and to monitor its effects
- A traffic organisation service is a service to prevent the development of dangerous maritime traffic situations and to provide for the safe and efficient movement of vessel traffic within the VTS area

Potential for confusion arises as it is incumbent upon the navigator to be familiar with the types of service being provided by the VTS in a particular area. The nature of a specific VTS should be widely and clearly promulgated. (Usually this can be found in the Admiralty List of Radio Signals (ALRS) and on charts, etc.).

Traffic management implications from a channel design and operation perspective are primarily it about what type of service is available to assist the navigator. For example, a narrow channel in a busy port approach may require a Traffic Organisation Service, whereas a relatively quiet port may only need an Information service.

A VTS is particularly appropriate in an area that may include any of the following:

- High traffic density
- Narrow channels, port configuration, bridges and similar areas where the progress of vessels may be restricted
- Existing or foreseeable changes in the traffic pattern resulting from port or offshore terminal developments or offshore exploration and exploitation in the area
- Traffic carrying hazardous cargoes
- Conflicting and complex navigation patterns
- Difficult hydrographical, hydrological and meteorological elements
- Shifting shoals and other local hazards
- Environmental considerations
- Interference by vessel traffic with other marine-based activities
- A record of maritime casualties
- Existing or planned vessel traffic services in adjacent waters and the need for co-operation between neighbouring states, if appropriate

4.6.4 Future Development of AtoN

There are several very interesting development projects and new designs in the field of AtoN. The lighting of AtoN is evolving with LED (Light Emitting Diode) systems. The lighting power of an individual buoy may be 10 times greater than with other lamp systems. Additionally, only 25 % of the original power may be used. Another development is the synchronisation of channel buoy lights.

Another development is remote monitoring of AtoN. GNSS and radio modules are placed in an AtoN so that it knows where it is and where it should be. The AtoN notifies the appropriate authority when it is misplaced or it has some other malfunction, e.g. battery failure. Polling of the AtoN for its position and status is also possible. This remote monitoring system can have huge potential savings in channel maintenance.

Combining AIS with AtoN are new concepts that are under development. In one scenario, an AtoN will have an AIS transmitter in it so it may be seen as an AIS target on an ECDIS screen. Remote monitoring is possible by this method too. A potential problem of this system is the already crowded AIS radio frequency. Another concept with AIS and AtoN is that there is no real physical AtoN present, but a virtual AtoN is displayed on the ECDIS-screen via AIS. This is accomplished by broadcasting the virtual AtoN from an onshore station to all ECDIS users. This is a handy and fast way to mark a danger, as for example in the case of a wreck, there is no need of expensive AtoN installations. This application of AtoN is recommended only as a temporary marker, as it should be noted that vessels that do not use ECDIS cannot see a virtual AtoN.

5 REFERENCES

Chapter 1 (General Aspects)

CANADIAN COAST GUARD (2001a): "Safe Waterways" (A Users Guide to the Design, Maintenance and Safe Use of Waterways), Part 1(a) Guidelines for the Safe Design of Commercial Shipping Channels, Software User Manual Version 3.0. Waterways Development Division, Fisheries and Oceans Canada, December.

CANADIAN COAST GUARD (2001b): "Safe Waterways" (A Users Guide to the Design, Maintenance and Safe Use of Waterways), Part 1(b) Guidelines for the Safe Design of Commercial Shipping Channels. Waterways Development Division, Fisheries and Oceans Canada, December.

Groenveld, R., Beimers, B., Vis, F.C. (2003): "a simple method to assess nautical risks", book of abstracts copedec conference, colombo, sri lanka, 125-126.

Headquarters, U.S. Army Corps of Engineers (2002): "Engineering and Design": Hydraulic Design Guidance for Deep-draft Navigation Projects. Engineer Manual EM 1110-2-1613, Washington, DC.

Ministry of Land, Infrastructure, Transport and Tourism (MLIT) (2009): "Technical Standards and Commentaries for Port and Harbour Facilities in Japan" (2007). OCDE.

Marin, Flanders Hydraulics (2005): "Vrije Ruimte Rond Schepen op de Schelde" (Free Space Round Ships on the River Scheldt), July, Wageningen, The Netherlands.

McBride, M.W., Smallman, J.V., Huntington, S.W (1998): "Guidelines for Design of Approach Channels". *Proceedings PORTS '98*, ASCE, Long Beach, CA, 1,315-1,324.

Ohtsu, K., Yoshimura, Y., Hirano, M., Tsugane, M., Takahashi, H. (2006): "Design Standard for Fairway in Next Generation". *Asia Navigation Conference*, No. 26.

PIANC (1995): "Approach Channels: Preliminary Guidelines" - First Report of the Joint PIANC-IAPH Working Group II-30 in cooperation with IMPA and IALA, Supplement to Bulletin 87, Brussels, April.

PIANC (1997): "Approach Channels: A Guide for Design". Final Report of the Joint PIANC-IAPH Working Group II-30 in cooperation with IMPA and IALA, Supplement to *Bulletin 95*, Brussels, June.

Chapter 2 (Design of Vertical Channel Dimensions)

Akakura, Y., Takahashi, H. (1998): "Ship Dimensions of Design Ship under Given Confidence Limits", Technical Note, Port and Harbour Research Institute Ministry of Transport (PHRI), JAPAN, No.911, (In English), Sept.

Atkinson, E., O'Brien, P. (2008): "DUKC in Channel Design", 6th IHMA Conference, St Petersburg, Russia, May.

Barrass, C. B. (2002): "Ship Squat – A Guide for Masters", Private report, www.ship-squat.com.

Briggs, M. J., Borgman, L., Bratteland, E. (2003): "Probability Assessment for Deep Draft Navigation Channel Design", Elsevier Coastal Engineering Journal, 48, 29-50.

Briggs, M.J., Silver, A. L., Borgman, L. E. (2006): "Risk-Based Predictions for Ship Underkeel Clearance", ICCE 2006, San Diego, CA.

Briggs, M. J., Vantorre, M., Uliczka, K. And Debaillon, P. (2010): Chapter 26: "Prediction of Squat for Underkeel Clearance", Handbook of Coastal and Ocean Engineering (Editor: Y.C. Kim), World Scientific Publishing Company, Singapore, 723-774.

Briggs, M. J. (2011): "Sensitivity of PIANC Ship Squat Formulas in Unrestricted Channels", PIANC E-Magazine On Course, 142, January, 13-24.

Briggs, M.J., Henderson, W.G. (2011): "Vertical Ship Motion Study for Savannah", GA Entrance Channel, Coastal and Hydraulics Engineering Technical Report ERDC/CHL TR-11-5, U.S. Army Engineer Research and Development Center, Vicksburg, MS, Sep, 221 pp.

Briggs, M.J., Silver, A.L., Kopp, P.J. (2012): Chapter 6: "Risk-Based Channel Depth Design using CADET", Series on Coastal and Ocean Engineering Practice – Vol. 1 (Editor: Y.C. Kim), World Scientific Publishing Company, Singapore, 319-366.

Briggs, M. J., Silver, A.L. Kopp, P.J., Santangelo, F.A., Mathis, I.A. (2013): "Validation of a Risk-Based Numerical Model for Predicting Deep-Draft Underkeel Clearance", ASCE Journal of Waterway, Port, Coastal, and Ocean Engineering, Vol 139, No. 4, July 1, 2013, pp. 267-276.

Briggs, M. J., Demirbilek, Z., And Lin, L. (2013): "Vertical Ship Motion Study for Ambrose Entrance Channel", NY, Coastal and Hydraulics Engineering Technical Report ERDC/CHL TR-13-x (In publication), U.S. Army Engineer Research and Development Center, Vicksburg, MS, Sep, 215 pp.

Curtis B. (2011): "Maximising Vessel Utilisation through Channel Design", *Coasts and Ports*, Perth, Australia.

Dand, I.W., Lyon, P.R. (1993): "The Element of Risk in Approach Channel Design". *Int. Conf. on Maritime Technology. Challenges in Safety and Environmental Protection*. Singapore, Nov.

Eloot, K., Verwilligen, J., Vantorre, M. (2008): "An Overview of Squat Measurements for Container Ships in Restricted Water". In: *International conference on Safety and*

Operations in Canals and Waterways (SOCW 2008), Glasgow, UK, Varyani, K. ed. University of Strathclyde Glasgow and University of Glasgow, Sep 15, 106-116.

IPCC (2007): Contribution of Working Group II to the “Fourth Assessment Report of the Intergovernmental Panel on Climate Change”, M.L. Parry, O.F. Canziani, J.P. Palutikof, P.J. van der Linden, and C.E. Hanson (eds), Cambridge University Press, http://www.cambridge.org/features/earth_environmental/climatechange/wg2.htm , Cambridge, United Kingdom and New York, NY, USA.

Ministry of Land, Infrastructure, Transport and Tourism (MLIT). 2009. Japan: “Technical Standards and Commentaries for Port and Harbour Facilities in Japan” (2007). OEDI.

Moes, J. (2008): “Probability and Risk Criteria for Channel Design and Operation.” *Proceedings PIANC International Navigation Seminar*, Beijing, May 26-29.

O'brien, W.T., O'brien, P., Hens, C. (2012): “Use of Web-Based Decision Support Technology for In-Transit Under Keel Clearance Management”, *8th IHMA Conference*, Cork, May.

Ohtsu, K., Yoshimura, Y., Hirano, M., Tsugane, M., Takahashi, H. (2006): “Design Standards for Fairway in Next Generation”. *Asia Navigation Conference 2006*, No.26.

PIANC (1985): “Underkeel Clearance for Large Ships in Maritime Fairways with Hard Bottoms”, *Report of a working group of the Permanent Technical Committee II*, Supplement to Bulletin No. 51.

Savenije, R. (1996): “Probabilistic Admittance Policy Deep Draught Vessels”. *PIANC Bulletin* 91, June.

Strating, J., Schilperoort, T., Blaauw, H.G. (1982): “Optimization of Depths of Channels”, Publication No. 278, Delft Hydraulics Laboratory (now Deltares), September.

Takaki, M. (1977): “On the Ship Motions in Shallow Water” (Part 3). *Transaction of the West-Japan Society of Naval Architects*, No. 54, Japan.

Takahashi, H., Goto, A., Abe, M. (2006): Study on Standards for Main Dimensions of the Design Ship. Technical Note of National Institute for Land and Infrastructure Management, Ministry of Land, Infrastructure, Transport and Tourism (MLIT), No. 309, Japan, June.

Takahashi, H., Goto, A. (2007): “Study on Ship Height by Statistical Analysis – Standard of Ship Height of Design Ship (Draft)”. Research Report of National Institute for Land and Infrastructure Management, Ministry of Land, Infrastructure, Transport and Tourism (MLIT), No. 33, Japan, March.

Uliczka, K., Kondziella, B. (2006): “Dynamic Response of Very Large Container ships in Extremely Shallow Water”, *Proceedings 31st PIANC Congress*, Estoril, Spain.

Van De Kaa, E.J. (1984): “Safety Criteria For Channel Depth Design”. *Proc. Third Meeting of the U.S. / Dutch M.O.U. on Dredging and Dredged Material Disposal*, Working Group III: Navigation Channels, Charleston, SC, September.

Vantorre M., Laforce, E., Eloit, K., Richter, J., Verwilligen, J., Lataire, E. (2008): “Ship Motions in Shallow Water as the Base for a Probabilistic Approach Policy”. *Proceedings*

of the ASME International Conference on Offshore Mechanics and Arctic Engineering, OMAE 2008, June 15-20, Estoril, Portugal.

Chapter 3 (Channel Width, Harbour Entrances, Manoeuvring and Anchorage Areas)

Groenveld, R. (2001): Lecture Notes, *Delft University of Technology*, "Service Systems in Ports and Inland Waterways", Delft.

Groenveld, R. (2006). "Ship Traffic Simulation Study Port Extension Maasvlakte 2 of the Port of Rotterdam". *PIANC Congress 2006*, Estoril, Portugal, May.

Groenveld, R., Onassis, I., Van Wijhe, H.J. (2002): "Safety and capacity wet infrastructure Puerto America Venezuela." *Book of abstracts PIANC-AIPCN Congress*, Sydney, Australia, CD S7B P102, p 1-14.

Groenveld, R., Beimers, B., Vis, F.C. (2003): "A simple method to assess nautical risks." *Book of abstracts COPEDEC Conference*, Colombo, Sri Lanka, p 125-126.

Hirano, M., Takashina, J., Takaishi, Y., Saruta, T. (1980): "Ship Turning Trajectory in Regular Waves." *Transactions of the West-Japan Society of Naval Architects*, No.60.

Inoue, S., Hirano, M., Kijima, K., Takashina, J. (1981): "A Practical Calculation Method of Ship Manoeuvring Motion." *ISP (International Shipbuilding Progress)*, Vol.28, No.325

Kaarsemaker, Weiler, Kant, Verhey (2010): "Evaluation of flow field for impact on Flow fields", *PIANC Liverpool 2010*.

Kijima, K., Lee, M. (2002): "On the Safe Navigation Including the Interaction Forces between Ship and Ship", *Transactions of the West-Japan Society of Naval Architects*, No.104.

Kose, K., Yumuro, A., Yoshimura, Y. (1981): "Mathematical Model of Ship Manoeuvring Motion – Interactions among Hull, Propeller and Rudder, and its Expressions" – (in Japanese), *The 3rd Ship Manoeuvrability Symposium Text*, The Society of Naval Architects of Japan.

MARIN and Flanders Hydraulics (2005): "Vrije ruimte rond schepen op de Schelde" (Free space round ships on the river Scheldt). Wageningen, The Netherlands, July.

Ministry of Land, Infrastructure, Transport and Tourism (MLIT) (2009) Japan: "Technical Standards and Commentaries for Port and Harbour Facilities in Japan" (2007).

Ohtsu, K., Yoshimura, Y., Hirano, M., Tsugane, M., Takahashi, H. (2006): "Design Standards for Fairway in Next Generation". *Asia Navigation Conference 2006*, No.26.

Principle of Naval Architecture (2nd Revision) (1989) Vol.3, SNAME.

Yamano, T., Saito, Y. (1997): "An Estimation Method of Wind Force Acting on Ship's Hull" (in Japanese). *Journal of the Kansai Society of Naval Architects*, No.228.

Chapter 4

USACE (Headquarters, U.S. Army Corps Of Engineers) (2006): "Engineering and Design: Hydraulic Design Guidance for Deep-draft Navigation Projects". Engineer Manual EM 1110-2-1613, Washington, DC, May 31.

IALA (2010): “Navguide - Aids to Navigation Manual”, 2010 Edition, *IALA*.

ROM (Puerto Del Estado) (2007): “Recommendations for Designing the Maritime Configuration of Ports, Approach Channels and Harbour Basins”. *ROM 3.1-99*. Spain: CEDEX.

PIANC EnviCom WG4 (1999)

PIANC EnviCom WG8 (2006)

PIANC EnviCom WG10 (2006)

PIANC EnviCom WG100 (2009)

PIANC EnviCom WG104 (2009)

Appendix C (Typical Ship Dimensions)

Akakura, Y., Takahashi, H. (1998): “Ship Dimensions of Design Ship under Given Confidence Limits”, Technical Note, Port and Harbour Research Institute Ministry of Transport (PHRI), JAPAN, No.911, (In English), Sept.

Lloyd’s Register Fairplay Data (2006) Lloyd’s Register Fairplay Ltd., September.

Ministry of Land, Infrastructure, Transport and Tourism (MLIT), Japan (2009): “Technical Standards and Commentaries for Port and Harbour Facilities in Japan” (2007). OCIDI,

Takahashi, H., Goto, A., Abe, M. (2006): “Study on Standards for Main Dimensions of the Design Ship”. Technical Note of National Institute for Land and Infrastructure Management, Ministry of Land, Infrastructure, Transport and Tourism (MLIT), No. 309, Japan, June.

Takahashi, H., Goto, A. (2007) “Study on Ship Height by Statistical Analysis – Standard of Ship Height of Design Ship” (Draft). Research Report of National Institute for Land and Infrastructure Management, Ministry of Land, Infrastructure, Transport and Tourism (MLIT), No. 33, Japan, March.

Appendix D (Prediction of Ship Squat)

Ankudinov, V.K., Jakobsen, B.K. (1996): “Squat Predictions at an Early Stage of Design.” *Workshop on Ship Squat in Restricted Waters*, SNAME, Jersey City, NJ, 48-69.

Ankudinov, V., Daggett, L. Huval, C., Hewlett, C. (1996): “Squat Predictions for Manoeuvring Applications”. *International Conference on Marine Simulation and Ship Manoeuvrability* (MARSIM’ 96), September 9-13. Copenhagen, Denmark, 467-495.

Ankudinov, V., Daggett, L.L., Hewlett, J.C., Jakobsen, B. K. (2000): “Prototype Measurement of Ship Sinkage in Confined Water.” *Proceedings of the International Conference on Marine Simulation and Ship Manoeuvrability* (MARSIM 2000), May 8-12. Orlando, FL.

Barrass, C.B. (1979): “A Unified Approach to Squat Calculations for Ships”. *PIANC Bulletin* 32:3-10.

- Barrass, C.B. (1994a): "Further Discussion on Squat", *Seaways*, March, 4-6.
- Barrass, C.B. (1994b): "Change of Trim as a Ship Squats", *Seaways*, October, 30-32.
- Barrass, C.B. (2002): "Ship Squat – A Guide for Masters", Private report, www.ship-squat.com.
- Barrass, C.B. (2004): "Thirty-Two Years of Research into Ship Squat", *Squat Workshop 2004*, Elsfleth/Oldenburger, Germany.
- Barrass, C.B. (2006) www.ship-squat.com
- Barrass, C.B. (2009) "*Ship Squat and Interaction*", Withersby Publishing & Seamanship, Livingston, U.K.
- Beck, R.F., Newman, J.N., Tuck, E.O. (1975) "Hydrodynamic Forces on Ships in Dredged Channels." *J. Ship Res.*, 9(3), 166-171.
- Briggs, M.J. (2006): "Ship Squat Predictions for Ship/Tow Simulator. Coastal and Hydraulics Engineering Technical Note CHETN-I-72, U.S. Army Engineer Research and Development Center, Vicksburg, MS, 2006, <http://chl.wes.army.mil/library/publications/chetn/>.
- Briggs, M.J. (2009a): "Ankudinov Ship Squat Predictions - Part I: Theory, Parameters, and FORTRAN Programs". Coastal and Hydraulics Engineering Technical Note CHETN-IX-19, U.S. Army Engineer Research and Development Center, Vicksburg, MS, August, <http://chl.wes.army.mil/library/publications/chetn/>.
- Briggs, M.J. (2009b): "Sensitivity Study of PIANC Ship Squat Formulas." *International Conference on Ship Manoeuvring in Shallow and Confined Water: Bank Effects*, May, Antwerp, Belgium.
- Briggs, M.J., Daggett, L. (2009) "Ankudinov Ship Squat Predictions - Part II: Laboratory and Field Comparisons and Validations", Coastal and Hydraulics Engineering Technical Note CHETN-IX-20, U.S. Army Engineer Research and Development Center, Vicksburg, MS, August, <http://chl.wes.army.mil/library/publications/chetn/>.
- Briggs, M.J. Debaillon, P., Uliczka, K., Dietze, W. (2009): "Comparisons of PIANC and Numerical Ship Squat Predictions for Rivers Elbe and Weser", *Nautical Aspects of Ship Dynamics – 3rd Squat-Workshop*, Elsfleth, Germany, October 21-22, 133-154.
- Briggs, M.J., Vantorre, M., Uliczka, K., Debaillon, P. (2010): Chapter 26: "Prediction of Squat for Underkeel Clearance", Editor: Young C. Kim, *Handbook of Coastal and Ocean Engineering*, World Scientific Publishing Co., Singapore, 723-774.
- Briggs, M.J. (2011): "Sensitivity of PIANC Ship Squat Formulas in Unrestricted Channels", *PIANC On Course E-Magazine*, No 142-2011, January 2011, 13-24.
- Briggs, M.J., Kopp, P.J., Ankudinov, V., Silver, A.L. (2011): "Ship Squat Comparison and Validation Using PIANC, Ankudinov, and BNT Predictions", *2nd International Conference on Ship Manoeuvring in Shallow and Confined Water: Ship-to-Ship Interaction*, Trondheim, Norway, May 18-20, 12 pages.

Briggs, M.J., Kopp, P.J., Ankudinov, V.K., Silver, A.L. (2013): "Comparison of Measured Ship Squat with Numerical and Empirical Methods", Society of Naval Architects and Marine Engineers (SNAME), *Journal of Ship Research*, Vol 57, No. 2, June, pp. 73-85.

Briggs, M.J. (2013): "Update to Ship Squat Predictions for Ship/Tow Simulator". Coastal and Hydraulics Engineering Technical Note CHETN-I-xx (In publication), U.S. Army Engineer Research and Development Center, Vicksburg, MS, 2006, <http://chl.wes.army.mil/library/publications/chetn/>.

Cong, L., Hsiung, C.C. (1991): "Computing Wave Resistance, Wave Profile, and Sinkage and Trim of Transom Stern Ships." *Proceedings Third International Conference on Computer Aided Design, Manufacture and Operation in the Marine and Offshore Industries* (CADMO 91), Key Biscayne, 99-112.

Debaillon, P., Lefrancois, E., Sergent, P., Dhatt, G. (2004): "Numerical Modelling of Ship Squat in Shallow Restricted Water." *2nd Squat Workshop*, March, Elsfleth/Oldenburger, Germany.

Debaillon, P. (2009): "Modélisation Numérique du Surenforcement des Navires." *PIANC Magazine* N° 134, January, 33-43.

Debaillon, P., Lataire, E., Vantorre, M. (2009): "Bank Effect on Ship Squat." *International Conference on Ship Manoeuvring in Shallow and Confined Water: Bank Effects*, May, Antwerp, Belgium.

Demirbilek, Z., Sargent, F. (1999): "Deep-draft Coastal Navigation Entrance Channel Practice." Coastal Engineering Technical Note CETN-I-63, U.S. Army Engineer Research and Development Center, Vicksburg, MS.

Eloot, K., Verwilligen, J., Vantorre, M. (2008) "An Overview Of Squat Measurements For Container Ships In Restricted Water." In: *International conference on Safety and Operations in Canals and Waterways (SOCW 2008)*, Glasgow, UK, Varyani, K. ed. University of Strathclyde Glasgow and University of Glasgow, Sep 15, 106-116.

Eryuzlu, N.E., Cao, Y.L., D'agnolo, F. (1994): "Underkeel Requirements for Large Vessels in Shallow Waterways." *Proceedings 28th International Navigation Congress*, PIANC, Paper S II-2, Sevilla, Spain, 17-25.

Flügge, G., Uliczk, A.K. (2001): "Dynamisches Fahrverhalten und Wechselwirkungen mit der Fahrinnensohle von sehr grossen Containerschiffen unter extremen Flachwasserbedingungen". *Hansa*.

Gourlay, T. (2009): "Sinkage and Trim of Two Ships Passing Each Other on Parallel Courses." *Ocean Eng.*, 36(14), 1119-1127.

Guliev, U.M. (1971): "On Squat Calculations for Vessels Going in Shallow Water and Through Channels." *PIANC Bulletin* 1(7):17-20.

Härting, A. Laupichler, A., Reinking, J. (2009): "Considerations on the Squat of Unevenly Trimmed Ships", *Ocean Engineering*, Elsevier, 36, 193-201.

Huuska, O. (1976): "On the Evaluation of Underkeel Clearances in Finnish Waterways." Helsinki University of Technology, Ship Hydrodynamics Laboratory, Otaniemi, Report No. 9.

- Jiang, T. (2003): "Numerical Prediction of Ship's Squat and Trim in Shallow Water." *MARSIM '03*, Kanazawa, Japan, August 25-28, RC-15-1 to RC-15-8.
- Moes, J. (2004): "Squat and Wave Response Measurements of Bulk Carriers in the Entrance Channel to the Port of Richards Bay." *2nd Squat Workshop*, Elsfleth, Germany, March 3-4.
- Nautical Technology Consultants (2006): "Welcome To UKC Voyage Planner User's Manual." Raften, NO-8325 Tengelfjord, Norway.
- Nawrocki, S. (1994): "Full-Scale Measurements of Sinkage and Trim of a Bulk Carrier." *PIANC Bulletin* 82:77-82.
- PANEL H-10 (Ship Controllability) (1996): "*Workshop on Ship Squat in Restricted Waters*." Society of Naval Architects and Marine Engineers, Hydrodynamics Committee. Jersey City, NJ, July.
- Reinking, J., Laupichler, A., Härting, A. (2009): "On the Dynamic Trim of Container Ships", *Nautical Aspects of Ship Dynamics – 3rd Squat-Workshop*, Elsfleth, Germany, October 21-22, 88-99.
- Römisch, K., Führer (1977): "Section I – Inland Navigation, Subject 3." *PIANC Congress*, Leningrad, Russia, pg. 80.
- Römisch, K. (1993): "Der Squat in Begrenzten Fahrwassern Betrachtung aus Hydro-mechanischer Sicht." *Schiff & Hafen / Seewirtschaft, Heft 10*, 58-62.
- Römisch, K. (1993): "Der Squat in Begrenzten Fahrwassern Betrachtung aus Hydro-mechanischer Sicht." *Schiff & Hafen / Seewirtschaft, Heft 10*, 58-62.
- Söding, H., Bertram, V. (2009): "A 3-D Rankine Source Seakeeping Method." *Ship Techn. Res.*, 56(2), 50-68.
- Stocks, D.T., Dagget, L.L., Page, Y. (2002): "Maximization of ship draft in the St. Lawrence Seaway Volume I: Squat Study." Prepared for Transportation Development Centre, Transport Canada, June.
- Tuck, E.O. (1966): "Shallow Water Flows Past Slender Bodies." *J. Fluid Mech.*, 26, 81-95.
- Tuck, E.O., Taylor, P.J. (1970): "Shallow Water Problems in Ship Hydrodynamics." *Proceedings 8th Symposium on Naval Hydrodynamics*. Pasadena, CA.
- Urlaub, M. (1993): "Squat and Keel Clearance - Problems and Repercussions from a Pilot's Point of View" (in German). *Schiff & Hafen / Seewirtschaft*, Vol. 45, No. 1, January, 44 p.
- Varyani, K.S. (2006): "Squat Effects on High Speed Craft in Restricted Waterways." *Journal of Ocean Engineering* 33(3-4):365-381.
- Yoshimura, Y. (1986): "Mathematical Model for the Manoeuvring Ship Motion in Shallow Water." *Journal of the Kansai Society of Naval Architects, Japan*, No. 200.

Appendix E (Behaviour of Ships in Muddy Areas)

Alexander, M. P., Teeter, A. M., Banks, G. E. (1997): "Development and Verification of an Intrusive Hydrographic Survey System for Fluid Mud Channels." *Tech. Rep. No. DRP-97-1*, U.S. Army Engineer Waterways Experiment Station, Vicksburg, MS.

Aster, D., Meyer, E. (1990): "Verbesserte Bestimmung der nautischen Tiefe im Emden Fahrwasser." *Hansa*, 127. Jahrgang, Nr. 23-24, S. 1729-1733.

Claeys, S. (2006): "Evaluation and combination of techniques used to determine the nautical bottom: a call for rheology based instruments", In: Evolutions in hydrography, 6th - 9th November 2006, Provincial House Antwerp, Belgium: *Proceedings of the 15th International Congress of the International Federation of Hydrographic Societies*. Special Publication of the Hydrographic Society, 55: 141-144.

De Brauwer, D. (2005): "Maintenance dredging and bottom survey in the harbour of Zeebrugge." *Workshop Nautical Bottom*, Flanders Hydraulics Research & Ghent University, Antwerp,
http://watlab.lin.vlaanderen.be/nautische/WorkshopNauticalBottom_DirkDeBrauwer.pdf

Mcanally, W., Friedrichs, C., Hamilton, D., Hayter, E., Shrestha, P., Rodriguez, H., Sheremet, A., Teeter, A. (ASCE Task Force on Management of Fluid Mud) (2007): "Management of Fluid Mud in Estuaries, Bay, and Lakes", I: Present State of Understanding on Character and Behaviour. *ASCE Journal of Hydraulic Engineering*, Vol 133, No 1, January 1.

PIANC PTC II (1989): "Economic methods of channel maintenance." Report of Working Group 14. *Supplement to PIANC Bulletin* No. 67, PIANC, Brussels.

Teeter, A. M. (1992): "Evaluation of a New Fluid Mud Survey System at Field Sites." *Dredging Research Rep. No. DRP-2-05*, U.S. Army Engineer Waterways Experiment Station, Vicksburg, MS.

Uliczka, K., Liebetruh, F. (2005): "Investigations of the BAW to the Nautical Bottom." *Workshop Nautical Bottom*, Flanders Hydraulics Research & Ghent University, Antwerp.
http://watlab.lin.vlaanderen.be/nautische/WorkshopNauticalBottom_KlemensUliczka.pdf

Van Craenenbroeck, K., Vantorre, M., De Wolf, P. (1991): "Navigation in Muddy Areas: Establishing the Navigable Depth in the Port of Zeebrugge." *Proceedings CEDA-PIANC Conference*, Accessible Harbours, Amsterdam, November.

Vantorre, M. (2001): "Nautical bottom approach – Application to the access to the harbour of Zeebrugge." *HANSA – Schiffahrt – Schiffbau – Hafen*, 138. Jahrgang, Nr. 6, S. 93-97.

Vantorre, M., Laforce, E., Delefortrie, G. (2006): "A novel methodology for revision of the nautical bottom", In: Peeters, Y. et al. (Ed.) (2006). Seminar: *Flanders, a maritime region of knowledge (MAREDFlow)*, 24 March 2006, Flanders Marine Institute (VLIZ), Oostende, Belgium. VLIZ Special Publication, 29: 15-34.
<http://www.vliz.be/imisdocs/publications/97166.pdf>

Wurpts, R. (2005): "Density, viscosity, yield stress." *Workshop Nautical Bottom*, Flanders Hydraulics Research & Ghent University, Antwerp.
http://watlab.lin.vlaanderen.be/nautische/WorkshopNauticalBottom_wurpts.pdf

Wurpts, R., Torn, P. (2005): "15 Years Experience with Fluid Mud: Definition of the Nautical Bottom with Rheological Parameters." *Terra et Aqua*, No. 99, 22-32, June 2005. http://www.terra-et-aqua.com/dmdocuments/99_04.pdf

Appendix F (Air Draught)

MLIT (Japanese Ministry of Land, Infrastructure, Transport and Tourism) (2007): "Technical Standards and Commentaries for Port and Harbour Facilities in Japan" (In English), *OCDI*, 2009.

Takahashi, H., Goto, A. (2006): "Study on Standards for Ship Height of the Design Ship." Research Report of National Institute for Land and Infrastructure Management Ministry of Land, Infrastructure and Transport (MLIT), No. 31. Japan, November.

Takahashi, H., Goto, A. (2007): "Study on Ship Height by Statistical Analysis – Standard of Ship Height of Design Ship (Draft)". Research Report of National Institute for Land and Infrastructure Management, Ministry of Land, Infrastructure and Transport (MLIT), No. 33. (In English) Japan, March.

APPENDIX G (Spanish and Japanese Methods for Design of Channel Width)

Appendix G - Chapter G1:

Groenveld, R., Onassis, I., Van Wijhe, H.J. (2002): "Safety and Capacity Wet Infrastructure Puerto America Venezuela", *Book of Abstracts PIANC-AIPCN Congress*, Sydney, Australia, CD S7B P102, 1-14.

Groenveld, R. (2006): "Ship Traffic Simulation Study Port Extension Maasvlakte 2 of the Port of Rotterdam", *PIANC Congress*, May 2006, Estoril, Portugal.

Puertos Del Estado (1999): "Recommendations for Maritime Works (Spain)" ROM 3.1-99: Designing Maritime Configuration of Ports, Approach Channels and Floatation Areas, Spain: CEDEX.

ROM 3.1-99 (1999): "Recommendations for the Design of the Maritime Configuration of Ports, Approach Channels and Harbour Basins", Puertos del Estado.

ROM (Puerto Del Estado) (2007): "Recommendations for Designing the Maritime Configuration of Ports, Approach Channels and Harbour Basins." ROM 3.1-99. Spain: CEDEX.

SNAME (Society of Naval Architects and Marine Engineers) (1989): "*Principle of Naval Architecture*" (2nd Revision), Vol.3.

Tsugane, M. (2009): "A Statistic Analysis of GOM and Other Values on Operation of Large Container Ships." *Journal of Japan Institute of Navigation*, No.120, Japan Institute of Navigation.

Appendix G - Chapter G2:

Inoue, S., Hirano, M., Kijima, K., Takashina, J. (1981): "A Practical Calculation Method of Ship Manoeuvring Motion", *ISP (International Shipbuilding Progress)*, Vol.28, No.325.

Kijima, K., Lee, M. (2002): "On the Safe Navigation Including the Interaction Forces between Ship and Ship", *Transactions of the West-Japan Society of Naval Architects*, No.104 (8).

Kose, K., Yumuro, A., Yoshimura, Y. (1981): "Mathematical Model of Ship Manoeuvring Motion – Interactions among Hull, Propeller and Rudder, and its Expressions" – (in Japanese), The 3rd Ship Manoeuvrability Symposium Text, *The Society of Naval Architects of Japan*.

MARIN, Flanders Hydraulics (2005): "Vrije ruimte rond schepen op de Schelde" (Free Space Around Ships on the River Scheldt). July, Wageningen, The Netherlands.

MILT (Ministry of Infrastructure, Land, Transport and Tourism, Japan) (2007): "Technical Standards and Commentaries for Port and Harbour Facilities in Japan", *OCDI*, 2009.

Ohtsu, K., Yoshimura, Y., Hirano, M., Tsugane, M., Takahashi, H. (2006): "Design Standard for Fairway in Next Generation." *Asia Navigation Conference*, No. 26.

SNAME (Society of Naval Architects and Marine Engineers) (1989): "*Principle of Naval Architecture*" (2nd Revision), 1989. Vol.3.

Yamano, T. And Saito, Y. (1997): "An Estimation Method of Wind Force Acting on Ship's Hull" (in Japanese), *Journal of the Kansai Society of Naval Architects*, No.228.

Appendix G - Chapter G3:

Hirano, M., Takashina, J., Takaishi, Y., Saruta, T. (1980): "Ship Turning Trajectory in Regular Waves", *Transactions of the West-Japan Society of Naval Architects*, No.60.

Inoue, S., Hirano, M., Kijima, K., Takashina, J. (1981): "A Practical Calculation Method of Ship Manoeuvring Motion", *ISP (International Shipbuilding Progress)*, Vol.28, No.325.

SNAME (Society of Naval Architects and Marine Engineers) (1989): "*Principle of Naval Architecture*" (2nd Revision), Vol.3.

Yamano, T., Saito, Y. (1997): "An Estimation Method of Wind Force Acting on Ship's Hull" (in Japanese), *Journal of the Kansai Society of Naval Architects*, No.228.

6 APPENDIX A TERMS OF REFERENCE



PIANC Maritime Navigation Commission – MarCom

Working Group 49
Horizontal and Vertical Dimensions of Fairways

TERMS OF REFERENCE

Historical Background - Definition of the Problem:

Ensuring the continued safety and efficiency of ships transiting dredged channels in the years ahead will require channel designers and naval architects alike to better understand the handling and manoeuvrability of both existing and new generation ships in shallow and restricted waters. In particular, PIANC has a desire to address the issues of horizontal and vertical dimensions (clearances) relating to ship channel and manoeuvring area design.

Objectives of the Study:

The objectives of the Working Group examining the horizontal and vertical dimensions of fairways will be to review, update and, where appropriate, expand on the design recommendations on horizontal and vertical dimensioning as presented in the Working Group 30 report of 1997 on approach channels. In doing so, the Working Group should consider recent developments in simulation and other design tools and the sizes and handling characteristics of new generation vessels.

Earlier Reports Reviewed:

The design of approach channels and fairways was first considered by PIANC in a report published by Working Group 2 of the PIANC International Oil Tankers Commission (IOTC) in 1972. Some years later, this work was reviewed by Working Group 4 of the PIANC International Commission for the Reception of Large Ships (ICORELS) in a report published in 1980. The subject was most recently considered by the joint PIANC-IAHP Working Group PTC II-30 in co-operation with IMPA and IALA. Their findings were published, first as a preliminary set of concept design guidelines in 1995, followed by the 1997 final report 'Approach Channels – A guide for design'.

Matters Investigated:

The Working Group should consider the following issues and items:

- Design Vessels (current and new generation)
- Water Datum (CD/MLLW/MSL)
- Tidal Ranges
- Wind/Wave/Currents
- One/Two-Way Traffic
- Tug Assistance and Tug Efficiency
- Restrictions on pilot boarding and tug connection
- Protected Channels
- Entrance Channel/affects
- Speed Restrictions
- Bank Clearance
- Manoeuvring Lanes
- Manoeuvring areas and turning circles
- Manoeuvring in adverse conditions

- Clearance Between Ships(underway and moored)
- Buoy clearance
- Channel bends
- Channel design/alignment studies
- Obstructions (submerged, overhead)
- Pitch/Roll/Heave
- Draught and trim
- Squat
- Underkeel Clearance
- Shallow water effects
- Sinkage in fresh water
- Seawater intake clearance
- Air draught
- Use of high tides
- Safety criteria and risk assessment
- Study methodologies and appropriateness
- Visibility
- Ice

Method of Approach:

- Collation and review of recent developments in information and design tools (such as desk study methods, mathematical and physical modelling and simulation techniques) available to inform decisions on channel dimensioning, including research work in hand.
- Review and, where appropriate, update the PIANC-Working Group 30 on guidelines for horizontal and vertical design/dimensioning of approach channels published in 1997
- Preparation of an inventory of channel dimensions and channel restrictions at existing terminals and harbours
- Particularly, the Working Group should give priority to:
 - Vertical motions of ships in approach channels (due to squat, wave-induced motions, dynamic effects, etc.)
 - Vertical clearances under bridges, overhead cables, etc.
 - Safety criteria, assessment of levels of risk and appropriate clearance margins
 - Simulation of ships in channels
 - Methods for assessing environmental (Metocean) operating limits
 - New and future generation ship dimensions/manoeuvring characteristics
 - Manoeuvring limits in adverse conditions (e.g. tug effectiveness at speed and in adverse wave, current and wind conditions)
 - Restrictions on pilot boarding, tug attachment and detachment and the time required

It is anticipated this Working Group will be complete with its research of available literature, an inventory of channels, terminals and harbours with existing restrictions, projected vessel sizes and handling characteristics, associated clearance/dimension requirements within a two-year time frame.

Suggested Final Product of the Working Group:

The final report of the Working Group will provide guidelines and recommendations on the horizontal and vertical dimensions of approach fairways/channels to harbours and terminals, and the manoeuvring areas within harbours, for the purpose of assisting in the design process, along with defining restrictions to operations within a channel. This will incorporate establishing vertical bridge clearances and depth requirements.

The final report should be presented as an update of the PIANC Working Group 30 on guidelines for horizontal and vertical design/dimensioning of approach channels published in 1997.

The final report should also identify any topic on dimensioning of channels and fairways which may require further work/research.

Desirable Disciplines of the Members of the Working Group:

It is proposed this Working Group be composed of:

- Port engineers with contacts to their peers
- Marine engineering consultants
- Naval architects
- Port pilots
- Tug operators

7 APPENDIX B GLOSSARY, ABBREVIATIONS AND SYMBOLS

B.1 GLOSSARY

Several terms, expressions and abbreviations have been used in this report which may not be familiar to all users. A glossary of such terms is given below:

<i>Aids to Navigation (AtoN)</i>	Device external to a vessel designed to assist in the determination of its position and its safe course or to warn of changes or obstructions. In the case of channels such devices include buoys, piled beacons, leading lights, sector lights, radar reflectors, etc.
<i>air draught</i>	Vertical distance measured from the ship's waterline to the highest point on the ship.
<i>air draught clearance</i>	Vertical distance measured from the highest point on the ship up to the underside of an overhead obstruction (such as a bridge or power cable).
<i>bank effects</i>	Hydrodynamic effect caused by the proximity of a ship to a bank. Asymmetrical pressures acting on the ship may cause it to be sucked towards, and turned away from, the bank. Bank effects depend on speed, distance off, ship size, bank geometry and water depth/draught ratio.
<i>bend angle</i>	Angle between two legs of a channel which meet at a bend. Usually expressed as the change of heading for a ship using a bend, so that a '45° bend' means that a ship's track heading must change by 45° when navigating the bend.
<i>bend radius</i>	Radius from the centre of the bend to the centreline of the channel.
<i>channel width</i>	Defined in this report as the width at the bed of the channel.
<i>collision</i>	Collision occurs when two vessels underway come into contact.
<i>concept design</i>	Preliminary design of channel width, depth and alignment using data given in this report, together with other relevant data relating to ships and environment.
<i>deadweight tonnage (DWT)</i>	Weight (usually in metric tonnes) of a ship's cargo, fuel, water, crew, passengers and stores.
<i>Differential GPS (DGPS).</i>	Method of improving the accuracy of GPS by means of ground stations at known locations.
<i>detailed design</i>	Additional design process involved in refining and exploring aspects of the approach channel design once the initial width, depth and alignment have been determined. This is outlined in Section 1.4.1 and is not to be confused with 'detailed design' in the civil engineering sense.
<i>displacement</i>	Actual total weight of the vessel (usually in metric tonnes)
<i>downtime</i>	Period(s) of time for which the channel cannot be used. This may be due to maintenance, accidents, congestion, insufficient water depth (due to low tide height), excessive wind, waves or current for safe navigation, or other metocean conditions (visibility, ice, etc.).
<i>fairway</i>	Navigable waterway defined by the fairway buoys. This may or may not have a width equal to that of the channel.
<i>Froude Depth Number</i>	Most important dimensionless parameter is the depth Froude Number F_{nh} , which is a measure of the ship's resistance to motion in shallow water. The F_{nh} expresses the ship's speed as a fraction of a critical value \sqrt{gh} , which is the maximum velocity of a disturbance propagating in a free surface of unrestricted shallow water with depth h .

<i>gross tonnage (GT)</i>	Measure of the overall size of a ship determined in accordance with the provisions of the International Convention on Tonnage Measurement of Ships, 1969. No units required as it is a non-dimensional quantity.
<i>grounding</i>	Grounding occurs when a vessel under way comes into contact with the bed of waterway, berth or bank of a fairway, canal or river.
<i>impact</i>	Impact occurs when a vessel under way, or drifting, hits an immovable object such as a jetty.
<i>interaction</i>	Hydrodynamic effect induced on a ship when close to another ship or a bank. It causes asymmetric forces and moments to act on the ship which can cause it to move off course.
<i>marine impact assessment (MIA)</i>	Multidisciplinary method of assessing the effect of a change in the marine environment brought about by channels, new reclamations, changes in marine traffic, etc. The effect on marine risk is of paramount importance.
<i>Manoeuvrability Margin (MM):</i>	Manoeuvrability Margin is the critical value of net underkeel clearance that will allow the ship to safely manoeuvre. A value of UKC less than the MM may result in unstable and dangerous conditions for a ship in transit.
<i>metocean conditions</i>	Environmental conditions due to wind, wave, current, etc.
<i>navigation aid:</i>	Instrument, device, chart, etc. carried on board a vessel and intended to assist in its navigation.
<i>prevailing wind/current:</i>	Commonly occurring wind or current obtained from current and wind records. Currents will include tidal streams and wind-induced currents.
<i>risk</i>	Product of the probability of a hazard resulting in an adverse event, times the severity (or possibly cost) of the consequence of that event.
<i>Sea or Wind Sea</i>	<i>Wind waves are waves generated and affected by the local winds. These waves are characterised by short periods (typically more than 3 s and smaller than 8 s) and have a short-crested, irregular sea surface.</i>
<i>sheer</i>	Tendency of a ship to deviate from its chosen course. Usually this is caused by ship-ship interaction, bank effects, waves, high velocity local cross-currents, or wind squalls.
<i>stranding</i>	Consequence of a grounding in which the ship is left high and dry.
<i>striking</i>	Striking occurs when a ship underway hits a drifting floating object, such as a ship at anchor, floating dock or buoy.
<i>swell</i>	Swell waves are wind-generated waves that have travelled out of their generating area. Swell has more well-defined and flatter crests than wind waves. Swell wave periods are very regular, ranging from 8 to 30 s, although 15 to 30 s periods are rare.
<i>swept track</i>	Track swept out by the extremities of the ship when manoeuvring. It will generally be greater in bends than straight sections and in cross winds and currents. It will also be greater in deep water, under a given set of conditions, compared to shallow water.
<i>trade-off study</i>	Study in which various (often competing) options are weighed against each other with the view to achieving an acceptable compromise solution.
<i>trim</i>	Trim is the difference between draught forward and the draught aft, measured in metres (or sometimes degrees). Trim by the stern (i.e. deeper at the stern) is defined as positive.
<i>window</i>	Time period for which a channel is available for use (typically due to tide height).
<i>Vessel Traffic Service (VTS).</i>	Advisory service for mariners regarding ship operations in a port. Provided by an administration or Port Authority.

B.2 ABBREVIATIONS

ADC	Air Draught Clearance
AIS	Automatic Identification System
AP	Aft perpendicular
AtoN	Aids to Navigation
BS	British Standard
C	Canal channel type
CD	Concept Design
CEU	Car Equivalent Unit (10 m ² = 4.2 m x 2.38 m)
DD	Detailed Design
DGPS	Differential GPS
DUKC	Dynamic Underkeel Clearance
DWT	Deadweight Tonnage (metric tonnes)
ECS	Electronic Chart System
ECDIS	Electronic Chart Display System
eLORAN	Enhanced Long-RANGE Navigation system
EnviCom	Environmental Commission (PIANC)
FEU	Forty-foot Equivalent Unit
FP	Forward perpendicular
GNSS	Global Navigation Satellite System
GPS	Global Positioning System
GT	Gross Tonnage, no units as non-dimensional quantity
HAT	Highest Astronomical Tide
IAHR	International Association for Hydro-Environment Engineering & Research
IALA	International Association of Marine Aids to Navigation & Lighthouse Authorities
IAPH	International Association of Ports & Harbours
IMO	International Maritime Organisation
IMPA	International Maritime Pilots Association
IPCC	International Panel on Climate Change
ITTC	International Towing Tank Commission
LAT	Lowest Astronomical Tide
LNG	Liquefied Natural Gas
LPG	Liquefied Petroleum Gas
MarCom	Maritime Navigation Commission (PIANC)
MIA	Marine Impact Assessment
MLIT	Ministry of Land, Infrastructure, Transport and Tourism (Japan)
MM	Manoeuvrability Margin
MLLW	Mean Lower Low Water
MSL	Mean Sea Level
NILIM	National Institute for Land and Infrastructure Management (Japan)
OAS	Obstruction Assessment Surface
OBO	Ore/Bulk/Oil carriers
OCDI	Overseas Coastal Area Development Institute of Japan
PCC	Pure Car Carrier (car carrier with only cars)
PIANC	The World Association for Waterborne Transport Infrastructure
PPU	Portable Pilot Unit
R	Restricted channel type
RAO	Response Amplitude Operator
ROM	Recommendations for Maritime Works (Spanish)
RoRo	Roll-on/Roll-off
SWL	Still water level

TEU	Twenty-foot Equivalent Unit
U	Unrestricted channel type
UKC	Underkeel Clearance, gross
VLLC	Very Large Crude Carrier
VTS	Vessel Traffic Service
WL	Water line
WG	Working Group (PIANC)

B.3 SYMBOLS

Symbols cover all Chapters and Appendices except for Appendix G
(Based on ITTC Symbols and Terminology List, version 2011, September 2011 and IAHR List of Sea State Parameters, January 1986)

a, b, c	(-)	channel width factors for specifying type of channel (one-way/two-way/four-way)
a_i	(-)	coefficients for a least squares regression fit of K_i as a polynomial function of S
a_w	(m)	wave amplitude
A_c	(m ²)	equivalent wetted cross-sectional area of channel with extrapolated slopes to the water surface
A_j, A_{m0j}	(m)	total significant vertical ship motion amplitude for all keel points j
A_{m0}	(m)	significant vertical ship motion amplitude for all keel points j
A_N	(m)	maximum amplitude of vertical motions given a Rayleigh distribution of wave heights
A_p	(m)	vertical ship motion amplitude based on the Rayleigh distribution for a given probability of exceedance
A_s	(m ²)	ship's underwater amidships cross-sectional area
$A_{V,F}$	(m ²)	projected frontal area above waterline exposed to wind, or transverse windage
$A_{V,L}$	(m ²)	projected lateral or side area above waterline exposed to wind, or lateral windage
A_w	(m ²)	net cross-sectional area of waterway when occupied by a vessel = $A_c - A_s$
A_{WP}	(m ²)	ship's waterplane cross-sectional area
B	(m)	ship's beam, breadth moulded
\overline{BM}	(m)	transverse metacentre above centre of buoyancy
c	(m/s)	wave celerity
C_1	(-)	coefficient in the range of 0.5 to 2.0 used to calculate \overline{GM}
\overline{C}_1	(-)	maximum height coefficient used to determine $Z_{Max,3}$
C_2	(-)	coefficient that accounts for variations in the ship vertical movements due to wave height when determining $Z_{max,3}$
C_3	(-)	load condition coefficient that accounts for changes in the ship displacement relative to the assumed 90 % loading condition when determining $Z_{Max,3}$
C_4	(-)	distance between the longitudinal axis of ship and the canal axis
C_5	(-)	coefficient that accounts for variations in water depth for h/T ratios from 1.05 to 1.50 when determining $Z_{Max,3}$
C_6	(-)	wave-incidence angle adjustment relative to the ship's longitudinal axis
C_B	(-)	ship's block coefficient $\Delta / (\gamma_{sw} L_{pp} BT) = \nabla / L_{pp} BT$
C_C	(-)	Römisch celerity parameter for calculating squat for vessels in canals
C_F	(-)	Römisch vessel-shape correction factor for calculating bow squat
C_R	(-)	Römisch celerity parameter for calculating squat in restricted channels
C_S	(-)	Huuska/Guliev constant for calculating bow squat
C_S	(-)	ICORELS constant for calculating bow squat

C_{SF}	(-)	safety factor based on risk level
C_U	(-)	celerity parameter for calculating squat in Römisch 's formulae for vessels in unrestricted channels
C_V	(-)	Römisch ship-speed correction factor for vessel squat
C_{VP}	(-)	ship's prismatic coefficient
C_{WP}	(-)	ship's waterplane coefficient: $A_{WP} / (L_{pp}B)$
C_{Wy}	(-)	wind force coefficient
C_{yn}	(-)	regression coefficients for calculating C_{Yw}
C_{ynj}	(-)	empirical coefficients for lateral wind forces
C_z	(-)	mean sinkage coefficient (Tuck 1966)
C_θ	(-)	trim coefficient (Tuck 1966)
C_ϕ	(-)	coefficient for estimating ϕ_R from ϕ_{WR}
D	(m)	distance between ship hull and toe of the bank
$E1$		low risk of loss of human life or environmental damages in the event of an accident
$E2$		medium risk of loss of human life or environmental damages in the event of an accident
$E3$		high risk of loss of human life or environmental damages in the event of an accident
f	(1/s)	frequency = $1/T$
f_E	(1/s)	encounter frequency
f_K	(-)	bilge keel factor used in calculating bilge keel sinkage
f_p	(1/s)	peak frequency of wave spectrum
f_{st}	(1/s)	striking frequency
F	(N)	force, general
F_B	(m)	Barrass width of influence of a channel
F_K	(-)	bilge keel factor, accounts for significant curvature of bilge keel
F_{nh}	(-)	Depth Froude Number based on undisturbed depth: $V/(gh)^{1/2}$
F_{nL}	(-)	Froude Number based on characteristic length L
F_R	(-)	Rayleigh factor
F_s	(m)	sum of ship related (depth) factors
F_{Wy}	(N)	wind lateral force in the y-direction
g	(m/s ²)	gravitational acceleration
G	(m)	freeboard from the waterline to the top of the deck
\overline{GM}	(m)	transverse (i.e. y-axis) metacentric height of the ship
\overline{GM}_L	(m)	longitudinal (i.e. x-axis) centre of metacentric height
h	(m)	water depth
h_1	(m)	water depth measured above the interface between water and fluid mud
h_2	(m)	thickness of mud layer
h_{CD}	(m)	water depth below Chart Datum
h_e	(m)	water depth above the level of an embankment
h_{mT}	(m)	relevant water depth: $h - h_T(1 - h_M/h)$ [Römisch, 1989]
h_M	(m)	mean water depth of a restricted waterway or canal [Römisch, 1989]
h_S	(m)	mean height of the superstructure and cargo above the deck
h_T	(m)	height of dredged underwater trench from bottom
H	(m)	wave height from crest to trough
$H_{1/3}$	(m)	significant wave height based on time domain analysis, average of highest 1/3 of all wave heights
H_a	(m)	total air draught height
$H_{i,j}(\omega, \theta)$	(-)	response amplitude operator (RAO) at critical points j with $i = 1, 2, 3$ for heave, roll and pitch, respectively
H_j	(-)	combined RAO of the individual heave, roll and pitch RAOs

H_{kt}	(m)	height of the ship from keel to top of the mast
$(H_{max})_p$	(m)	maximum wave height whose exceedance probability is 'p'
H_{m0}	(m)	significant wave height calculated from the zeroth moment of the wave spectrum
H_N	(m)	expected maximum wave height given a Rayleigh distribution of wave heights
H_s	(m)	significant wave height, average of highest 1/3 of wave heights from time or frequency domain
H_{st}	(m)	air draught, height of the ship from sea surface to top of the mast
$H_{st,B}$	(m)	ship height from water surface to top of ship of a ballasted vessel
$H_{st,F}$	(m)	ship height from water surface to top of ship of a fully-loaded vessel
I_T	(m ⁴)	transverse second moment of waterplane area, inertia moment of flotation area
J	(-)	draught factor that relates the draught of a vessel to the full-load draught
k	(N/m)	hydrostatic stiffness = $\rho_w g A_{WP}$
k	(-)	shape parameter in an Erlang-k distribution
K	(-)	Barrass dimensionless coefficient for calculating maximum squat (S_{MaxB3})
K_1	(-)	Huuska/Guliev correction factor for determining s_1 when calculating bow squat
K_b	(-)	Eryuzlu correction factor for calculating bow squat
\overline{KB}	(m)	height of the ship centre of buoyancy measured from the keel
K_C	(-)	Römisch dimensionless correction factor for calculating vessel squat in a canal
\overline{KG}	(m)	height of the ship centre of gravity measured from the keel
\overline{KG}_w	(m)	height of the centre of windage lateral area measured from the keel
K_m	(-)	Barrass coefficient for determining vessel squat due to mean sinkage
K_{oe}	(-)	Barrass coefficient for determining vessel squat at the 'other end' of the vessel from the location of maximum squat
K_R	(-)	Römisch dimensionless correction factor for calculating vessel squat in a restricted channel
K_R	(-)	non-dimensional index of turning ability
K_s	(-)	Huuska/Guliev correction factor for channel width when calculating vessel squat
K_t	(-)	Barrass' coefficient for determining vessel squat due to dynamic trim
K_U	(-)	Römisch' dimensionless correction factor for calculating vessel squat in an unrestricted channel
$K_{\Delta T}$	(-)	Römisch 's critical ship speed correction factor for calculating bow squat
ℓ_R	(m)	heel moment arm due to ship turning
ℓ_W	(m)	heel moment arm due to wind force
L	(m)	characteristic length in F_{nL} ratio
L_F	(m)	distance for the drift detection between the ship and the light buoys ahead along the channel centreline
L_{oa}	(m)	ship's length overall
L_{pp}	(m)	ship's length between perpendiculars
L_W	(m)	ship length at waterline
m_a	(kg)	ship added mass or inertia
m_{0ij}	(m ²)	zero moment of ship motions at critical points j with $i = 1,2,3$ for heave, roll and pitch, respectively
m_s	(kg)	ship actual mass or displaced mass
m_v	(kg)	ship virtual mass = $m_s + m_a$
M	(N·m)	moment, general
	(m)	metacentre
M_W	(N m)	wind heel moment
n	(-)	bank slope of a channel ($n = \text{horizontal run/vertical rise}$)
N_{Case}	(-)	number of critical cases during the design life
N_0	(-)	number of waves encountered during vessel transit
N_p	(-)	average number of passages per year
N_w	(-)	number of waves that a ship can expect to encounter when determining $Z_{Max,3}$

N_y	(-)	number of years or return period
p	(-)	probability of bottom touching per event
$p(x)$	(1/x)	probability density function
P	(-)	coverage rate relating to confidence of data coverage from Japanese Statistical Analysis of Ship Dimensions
$P(x)$	(-)	probability function
P_{DL}	(-)	exceedance probability or acceptable failure probability during the design life
P_m	(-)	exceedance probability for each occurrence or critical manoeuvre
P_p	(-)	probability of exceedance per passage
P_{UKC}	(-)	probability that the UKC_{Net} will be exceeded
P_z	(-)	probability of exceedance of vertical ship motion amplitude
R_A	(m)	minimum radius of a free weathervaning anchorage
R_C	(m)	ship steady turning radius, bend radius of channel
R^2	(-)	correlation coefficient from least squares regression
S_{eff}	(-)	effective speed ratio = $v_x \cos(\psi)/c$
S	(-)	blockage factor, proportion of cross-sectional area of a channel occupied by the vessel, = A_s/A_c
S_1	(-)	Huuska/Guliev dimensionless corrected blockage factor for bow squat
S_2	(-)	velocity return factor for calculating the squat of a vessel = A_s/A_w
S_b	(m)	squat at the bow of a vessel
S_K	(m)	sinkage of the ship bilge keel
S_m	(m)	vessel squat due to mean sinkage
S_{Max}	(m)	maximum squat of a vessel
S_s	(m)	squat at the stern of a vessel
S_t	(m)	vessel squat due to dynamic trim
$S(\omega_e, \theta)$	(m ² s)	directional wave spectrum
t	(s)	time, variable
t	(s)	time duration of ship in channel
t	(s)	service or dwell time in a queuing process
t	(s)	inter-arrival time in a NED process
T	(m)	ship's draught, general
$T_{1/3}$	(s)	significant wave period calculated using zero downcrossing or upcrossing analysis
T_B	(m)	ballasted ship draught
T_{Design}	(m)	maximum design draught
T_E	(s)	encounter wave period
T_{FL}	(m)	fully-loaded ship draught
T_{fw}	(m)	fresh water draught
T_H	(s)	ship natural period in heave
T_p	(s)	peak wave period from wave spectrum
T_s	(s)	significant wave period, average of periods of highest 1/3 of zero downcrossing or upcrossing wave heights
T_s	(-)	concentration of solid material in mud
T_{sw}	(m)	seawater or salt water draught
T_z	(s)	zero-crossing wave period
T_θ	(s)	ship natural period in pitch
T_ϕ	(s)	ship natural period in roll
U_C	(m/s)	ship speed at steady turning rate
UKC_{Net}	(m)	net underkeel clearance
v_x	(m/s)	ship speed over ground, ignoring any currents
V	(m/s)	ship speed through the water

V_{cc}	(m/s)	prevailing cross-current speed
V_{Cr}	(m/s)	critical ship speed
V_{cw}	(m/s)	prevailing cross wind speed
V_e	(m/s)	Yoshimura equivalent ship velocity used in squat formula
$V_{F,1 min}$	(m/s)	current speed averaged over 1 min
V_k	(knots)	ship speed (relative to the water) in knots
V_{lc}	(m/s)	prevailing longitudinal current speed
V_s	(m/s)	ship speed (relative to the water) in metric units
V_{sr}	(m/s)	reduced ship speed (40 % of the absolute maximum speed admissible in the fairway)
V_{WR}	(m/s)	ship speed (relative to the water) in metric units
$V_{W,1 min}$	(m/s)	wind velocity at a height of 10 m above sea level, as a 1-minute average
W	(m)	channel width, measured at bottom
W_B	(m ²)	ballasted lateral windage
W_{BG}	(m)	bank clearance on green side of channel
W_{BM}	(m)	width of basic or fundamental manoeuvring lane
W_{BR}	(m)	bank clearance on red side of channel
W_{CF}	(m)	additional width to account for current forces
W_{DD}	(m)	additional width to account for drift
W_{Eff}	(m)	effective channel width
W_{FL}	(m ²)	fully-loaded ballast windage
W_i	(m)	additional width for wind, current, etc.
W_{IF}	(m)	additional width to account for interaction forces
W_M	(m)	width of manoeuvring lane
W_{OV}	(m)	additional width to account for two-ship interaction in overtaking
W_p	(m)	passing distance
W_{PA}	(m)	additional width to account for two-ship interaction in passing
W_s	(m)	width of swept path
W_{Top}	(m)	width at the top of the channel
W_{WF}	(m)	additional width to account for wind forces
W_{YM}	(m)	additional width to account for yawing motion
x	(m)	ship longitudinal coordinate
x_L	(m)	distance between the forward perpendicular and the centre of $A_{V,L}$
X_j	(m)	x-axis distance of critical point from centre of gravity
y	(m)	ship lateral coordinate
Y_j	(m)	y-axis distance of critical point from centre of gravity
Y_L	(yr)	operational lifetime in years
z	(m)	ship vertical coordinate
Z_2	(m)	bow sinkage due to heave and pitch
Z_3	(m)	bilge keel sinkage due to heave and roll
$Z_{i,j}(\omega, \theta)$	(m ² s)	spectral density of vertical response at critical points j with i=1,2,3 for heave, roll and pitch, respectively
Z_{ij} or $Z_{m0i,j}$	(m)	significant/characteristic peak-to-peak or double amplitude of vertical motion
Z_{Max}	(m)	maximum vertical ship motions due to normal ship motions in waves
$Z_{Max,1}$	(m)	wave-induced vertical motions derived by trigonometric method 1
$Z_{Max,2}$	(m)	wave-induced vertical motion derived by Japanese method 2
$Z_{Max,3}$	(m)	wave-induced vertical motion allowance derived by Spanish ROM method 3
$Z_{Max,4}$	(m)	wave-induced vertical motions derived by probabilistic method 4
Z_N	(m)	maximum amplitude of vertical motions given a Rayleigh distribution of wave heights
Z_{Nj}	(m)	maximum amplitude of vertical motions at critical point 'j' given a Rayleigh

		distribution of wave heights
Z_R	(m)	sinkage due to ship turning only
Z_W	(m)	sinkage due to wind forces only
Z_{WR}	(m)	sinkage due to both turning and wind forces
Z_θ	(m)	vertical motion due to pitch
Z_ϕ	(m)	vertical motion due to roll
α	(-)	motion risk factor in CADET
α	(-)	coefficient for calculating $A_{V,F}$ or $A_{V,L}$ empirically using DWT or GT
β	(deg)	drift or yaw angle
β	(-)	channel reach risk level in CADET
β	(-)	exponent for calculating $A_{V,F}$ or $A_{V,L}$ empirically using DWT or GT
γ	(-)	effective wave slope coefficient
γ_{sw}	(kN/m ³)	specific weight of seawater
γ_w	(kN/m ³)	specific weight of water, fresh or seawater
$\dot{\gamma}$	(N/s·m ²)	shear rate
δ_R	(deg)	rudder angle
Δ	(N or kN)	ship's weight displacement in seawater
Δ_m	(kg or t)	ship's mass displacement
ΔS	(m)	increase/decrease in squat
ΔW	(m)	additional width to account for ship's swept path in bends
ΔW_{DA}	(m)	additional width of the vessel's path swept due to drift angle in curved channel section
ΔW_{RT}	(m)	additional width in bends to compensate for response time delay by ship handler in responding to required alteration of course
ϵ	(m)	displacement tolerance in squat numerical model
η	(N·s/m ²)	differential dynamic viscosity
θ	(deg)	wave direction
θ	(deg)	pitch angle
θ_{Max}	(deg)	maximum pitch angle
θ_{WR}	(deg)	relative wind direction angle
λ	(1/s)	ship arrival rate in a queuing process
λ	(m)	wavelength of sea waves in direction of propagation
μ	(-)	dimensionless rolling amplitude in regular waves
μ	(N·s/m ²)	dynamic viscosity
μ	(-)	service rate (number of services per time unit) in an M/E2/1 queue
ρ_a	(kg/m ³)	density of air
ρ_{fw}	(kg/m ³)	density of fresh water
ρ_m	(kg/m ³)	density of mud
ρ_s	(kg/m ³)	density of solid fraction (sediment) in mud
ρ_{sw}	(kg/m ³)	density of seawater
ρ_w	(kg/m ³)	density of water, fresh or seawater
σ_b	(m)	standard deviation of channel bed irregularities
σ_c	(m)	combined standard deviation of components that contribute to a required UKC
$\sigma_{i,j}^2$	(m ²)	variance at critical points j with $i = 1,2,3$ for heave, roll and pitch, respectively
σ_s	(m)	standard deviation of the motions of the design ship ($= \frac{1}{2} A_{mo}$)
σ_w	(m)	standard deviation of water levels
τ	(N/m ²)	shear stress
τ_0	(N/m ²)	yield stress or initial rigidity that has to be overcome to initialise material flow
φ	(-)	volume fraction of the solid component of mud
ϕ	(deg)	angle of heel/roll
ϕ_C	(deg)	heel angle due to ship steady turning

ϕ_{Max}	(deg)	maximum heel angle due to steady ship turning
ϕ_R	(deg)	heel angle due to ship turning forces only
ϕ_W	(deg)	heel angle due to wind forces only
ϕ_{WR}	(deg)	roll or heel angle due to both turning and windage
Φ	(deg)	wave slope angle
ψ	(deg)	wave encounter angle, course angle or heading, angle between ship positive x-axis and positive direction of waves or dominant wave direction
ω_e	(rad/s)	encounter circular frequency
∇	(m ³)	ship volume displacement

8 APPENDIX C TYPICAL SHIP DIMENSIONS

This appendix contains tables from the following sources:

- Table C-1: Typical ship dimensions from ROM 3.1
- Table C-2: Ship dimensions [Takahashi, 2006] as a function of coverage rate $P = 95\%$. Although not included, interested readers may check Takahashi (2006) for $P = 75\%$ data. Note: This table should be used as a supplementary reference to Table C-1
- Table C-3: Metacentric height estimates \overline{GM}/T_{Design} for range of ship types [Tsugane, 2009]

Newer generation ships will continue to come on line. Readers may want to check out sources such as Lloyd's Register Fairplay Data for the latest information on ship dimensions and design. Some of the material in this appendix is complementary to that in Appendix F. A list of symbols used in this appendix is given below:

Symbol	Description	Units
B	Beam, breadth	m
C_B	Block coefficient	--
CEU	Car Equivalent units	--
DWT	Deadweight Tonnage (metric tonnes) Note that 't' is abbreviation for tonnes.	tonnes or t
\overline{GM}	Metacentric height	m
GT	Gross Tonnage, volumetric measure	--
H_{kt}	Height from keel to top of ship	m
H_{st}	Height from sea or water surface to top of ship	m
L_{oa}	Length overall	m
L_{pp}	Length between perpendiculars	m
T	Maximum navigational, Loadline, or Plimsoll draught. It is based on the maximum draught for fully-loaded ships, at summer draught, in sea water, stationary condition and on even keel. This draught is the horizontal centreline of the Plimsoll Mark.	m
TEU	Twenty-foot Equivalent Units, different shipping companies may use different definitions for estimation of overall TEU capacity	--
Lateral Windage	Lateral projected area of ship, minimum or maximum. Windage is a function of type of ship and loading condition. Ships without cargo on deck (e.g. tankers, bulk carriers) have minimum windage when fully-loaded, but maximum windage when lightly loaded (i.e. ballast condition). For container vessels, the lateral projected area of the ship depends both on the draught and on the number of containers above deck; between both, there is no straightforward relationship due to the presence of empty containers.	m ²
Fully-Loaded Lateral Windage, W_{FL}	$W_B - (T_{FL} - T_B)(L_{pp} + L_{oa})/2$ W_B = Ballasted Lateral Windage. Note that can use L_{pp} only if L_{oa} is not available since this is a way to estimate windage. Also, use average ballasted draught if ship is trimmed with uneven keel.	m ²
Ballasted Draught, T_B	$T_B = T_{FL} - (W_B - W_{FL})/L_{oa}$. Derived from equation above for W_{FL} assuming that $(L_{pp} + L_{oa})/2 \sim L_{oa}$.	m
Δ	Maximum weight displacement = $\rho_{sw}g\nabla = g\Delta_m$	N or kN
Δ_m	Maximum mass displacement = $\rho_{sw}\nabla$	kg or t
∇	Volume displacement = $\Delta/(\rho_{sw}g)$	m ³

ρ_{sw}	Density of seawater	kg/m^3
-------------	---------------------	-----------------

Notes for table:

1. Container ship B is integer multiple of width of containers, plus additional space between container rows to place or remove the containers for cell guides, etc. For instance, Panamax container ship $B = 32.2$ m is integer multiple of 2.48 m for 13 rows. Newer Maersk Triple E-class (18,000 TEU) container ships with $B = 59.5$ m have room for 23 rows with approximate 2.57 m spacing.
2. Due to convention and common usage around the world, DWT is expressed in mass units of tonnes even though it is a force or weight. No additional conversion is required.
3. Mass: 1 tonne = 1 t = 1,000 kg. Force: 1 kgf = 9.81 N.
Specific weight of seawater: $\gamma_{sw} = \rho_{sw}g = 10.07$ kN/m³.
Density: $\rho_{sw} = 1,025$ kg/m³ = 1.025 t/m³.
Gravity: $g = 9.81$ m/s².
4. Several examples comparing W_{FL} and T_B are presented in Appendix F. In general, the differences between W_{FL} and W_B are greatest for 'weight' carriers, but ≤ 10 % for 'volume' carriers. Ballast conditions are usually not the driving force in channel width design, although a ballasted ship might affect the channel depth as it will respond differently to waves.

For more detailed definitions, interested readers may refer to IMO International Maritime Organisation (IMO 1969), International Towing Tank Commission [ITTC, 2011].

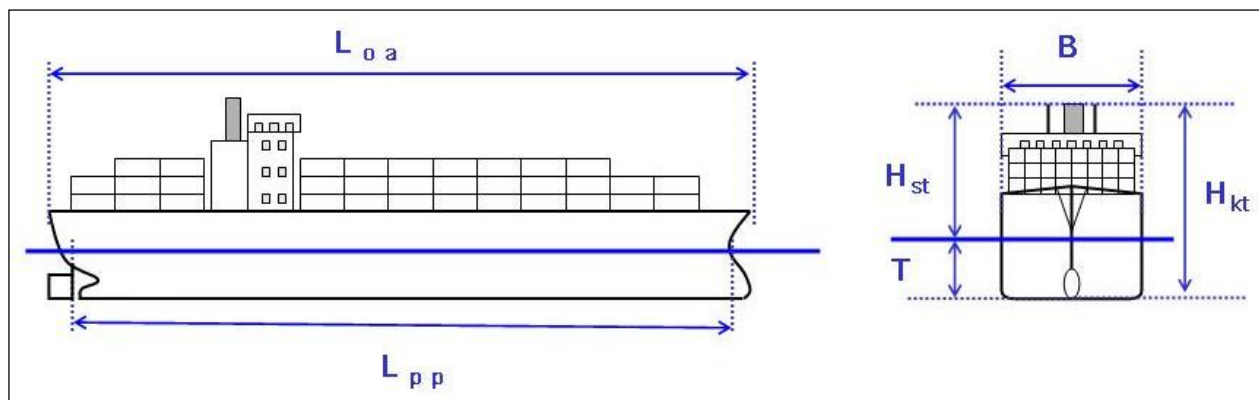

Figure C-1: Typical ship dimensions

C.1 Typical Ship Dimensions from ROM 3.1

DWT (t)	Δ_m (t)	L_{oa} (m)	L_{pp} (m)	B (m)	T (m)	C_B (-)	Min. Lateral Windage: Fully Loaded (m ²)	Max. Lateral Windage: In Ballast (m ²)	Approx. Capacity (m ³)
Tankers (ULCC)									
500,000	590,000	415.0	392.0	73.0	24.0	0.84	6,400	11,000	
400,000	475,000	380.0	358.0	68.0	23.0	0.83	5,700	9,700	
350,000	420,000	365.0	345.0	65.5	22.0	0.82	5,400	9,200	
Tankers (VLCC)									
300,000	365,000	350.0	330.0	63.0	21.0	0.82	5,100	8,600	
275,000	335,000	340.0	321.0	61.0	20.5	0.81	4,900	8,200	
250,000	305,000	330.0	312.0	59.0	19.9	0.81	4,600	7,700	
225,000	277,000	320.0	303.0	57.0	19.3	0.81	4,300	7,300	
200,000	246,000	310.0	294.0	55.0	18.5	0.80	4,000	6,800	
Tankers									
175,000	217,000	300.0	285.0	52.5	17.7	0.80	3,750	6,200	
150,000	186,000	285.0	270.0	49.5	16.9	0.80	3,400	5,700	
125,000	156,000	270.0	255.0	46.5	16.0	0.80	3,100	5,100	
100,000	125,000	250.0	236.0	43.0	15.1	0.80	2,750	4,500	
80,000	102,000	235.0	223.0	40.0	14.0	0.80	2,450	4,000	
70,000	90,000	225.0	213.0	38.0	13.5	0.80	2,250	3,700	
60,000	78,000	217.0	206.0	36.0	13.0	0.79	2,150	3,500	
Product and Chemical Tankers									
50,000	66,000	210.0	200.0	32.2	12.6	0.79	1,900	3,000	
40,000	54,000	200.0	190.0	30.0	11.8	0.78	1,650	2,600	
30,000	42,000	188.0	178.0	28.0	10.8	0.76	1,400	2,200	
20,000	29,000	174.0	165.0	24.5	9.8	0.71	1,100	1,800	
10,000	15,000	145.0	137.0	19.0	7.8	0.72	760	1,200	
5,000	8,000	110.0	104.0	15.0	7.0	0.71	500	800	
3,000	4,900	90.0	85.0	13.0	6.0	0.72	400	600	
Note: Dimensions given in the tables may vary up to $\pm 10\%$ depending on construction and country of origin.									

Table C-1: Typical ship dimensions from ROM 3.1 (Continued)

DWT (t)	Δ_m (t)	L_{oa} (m)	L_{pp} (m)	B (m)	T (m)	C_B (-)	Min. Lateral Windage: Fully Loaded (m ²)		Max. Lateral Windage: In Ballast (m ²)	Approx. Capacity (m ³)
Bulk Carriers /OBO's										
400,000	464,000	375.0	356.0	62.5	24.0	0.85	4,500		8,700	
350,000	406,000	362.0	344.0	59.0	23.0	0.85	4,400		8,500	
300,000	350,000	350.0	333.0	56.0	21.8	0.84	4,250		8,200	
250,000	292,000	335.0	318.0	52.5	20.5	0.83	4,000		7,700	
200,000	236,000	315.0	300.0	48.5	19.0	0.83	3,600		6,900	
150,000	179,000	290.0	276.0	44.0	17.5	0.82	3,250		5,900	
125,000	150,000	275.0	262.0	41.5	16.5	0.82	3,000		5,400	
100,000	121,000	255.0	242.0	39.0	15.3	0.82	2,700		4,800	
80,000	98,000	240.0	228.0	36.5	14.0	0.82	2,450		4,200	
60,000	74,000	220.0	210.0	33.5	12.8	0.80	2,050		3,500	
40,000	50,000	195.0	185.0	29.0	11.5	0.79	1,700		2,800	
20,000	26,000	160.0	152.0	23.5	9.3	0.76	1,400		2,300	
10,000	13,000	130.0	124.0	18.0	7.5	0.76	1,200		1,800	
LNG Carriers (Prismatic)										
125,000	175,000	345.0	333.0	55.0	12.0	0.78	8,400		9,300	267,000
97,000	141,000	315.0	303.0	50.0	12.0	0.76	7,000		7,700	218,000
90,000	120,000	298.0	285.0	46.0	11.8	0.76	6,200		6,800	177,000
80,000	100,000	280.0	268.8	43.4	11.4	0.73	6,000		6,500	140,000
52,000	58,000	247.3	231.0	34.8	9.5	0.74	4,150		4,600	75,000
27,000	40,000	207.8	196.0	29.3	9.2	0.74	2,900		3,300	40,000
LNG Carriers (Spheres, Moss)										
75,000	117,000	288.0	274.0	49.0	11.5	0.74	8,300		8,800	145,000
58,000	99,000	274.0	262.0	42.0	11.3	0.78	7,550		8,000	125,000
51,000	71,000	249.5	237.0	40.0	10.6	0.69	5,650		6,000	90,000
LPG Carriers										
60,000	95,000	265.0	245.0	42.2	13.5	0.66	5,600		6,200	
50,000	80,000	248.0	238.0	39.0	12.9	0.65	5,250		5,800	
40,000	65,000	240.0	230.0	35.2	12.3	0.64	4,600		5,100	
30,000	49,000	226.0	216.0	32.4	11.2	0.61	4,150		4,600	
20,000	33,000	207.0	197.0	26.8	10.6	0.58	3,500		3,900	
10,000	17,000	160.0	152.0	21.1	9.3	0.56	2,150		2,500	
5,000	8,800	134.0	126.0	16.0	8.1	0.53	1,500		1,700	
3,000	5,500	116.0	110.0	13.3	7.0	0.52	1,050		1,200	
Note: Dimensions given in the tables may vary up to $\pm 10\%$ depending on construction and country of origin.										

Table C-1: Typical ship dimensions from ROM 3.1 (Continued)

DWT (tonnes)	Δ (t)	L_{oa} (m)	L_{pp} (m)	B (m)	T (m)	C_B (-)	Min. Lateral Windage: Fully Loaded (m ²)	Max. Lateral Windage: In Ballast (m ²)	Approx. Capacity: TEU / CEU
Container Ships (Post-Panamax)									TEU
245,000	340,000	470.0	446.0	60.0	18.0	0.69	11,000	12,500	22,000
200,000	260,000	400.0	385.0	59.0	16.5	0.68	10,700	12,000	18,000
195,000	250,000	418.0	395.0	56.4	16.0	0.68	10,100	11,300	14,500
165,000	215,000	398.0	376.0	56.4	15.0	0.66	9,500	10,500	12,200
125,000	174,000	370.0	351.0	45.8	15.0	0.70	8,700	9,500	10,000
120,000	158,000	352.0	335.0	45.6	14.8	0.68	8,000	8,700	9,000
110,000	145,000	340.0	323.0	43.2	14.5	0.70	7,200	7,800	8,000
100,000	140,000	326.0	310.0	42.8	14.5	0.71	6,900	7,500	7,500
90,000	126,000	313.0	298.0	42.8	14.5	0.66	6,500	7,000	7,000
80,000	112,000	300.0	284.0	40.3	14.5	0.66	6,100	6,500	6,500
70,000	100,000	280.0	266.0	41.8	13.8	0.64	5,800	6,100	6,000
65,000	92,000	274.0	260.0	41.2	13.5	0.62	5,500	5,800	5,600
60,000	84,000	268.0	255.0	39.8	13.2	0.61	5,400	5,700	5,200
55,000	76,500	261.0	248.0	38.3	12.8	0.61	5,200	5,500	4,800
Container Ships (Panamax)									TEU
60,000	83,000	290.0	275.0	32.2	13.2	0.69	5,300	5,500	5,000
55,000	75,500	278.0	264.0	32.2	12.8	0.68	4,900	5,100	4,500
50,000	68,000	267.0	253.0	32.2	12.5	0.65	4,500	4,700	4,000
45,000	61,000	255.0	242.0	32.2	12.2	0.63	4,150	4,300	3,500
40,000	54,000	237.0	225.0	32.2	11.7	0.62	3,750	3,900	3,000
35,000	47,500	222.0	211.0	32.2	11.1	0.61	3,550	3,700	2,600
30,000	40,500	210.0	200.0	30.0	10.7	0.62	3,350	3,500	2,200
25,000	33,500	195.0	185.0	28.5	10.1	0.61	2,900	3,000	1,800
20,000	27,000	174.0	165.0	26.2	9.2	0.66	2,400	2,500	1,500
15,000	20,000	152.0	144.0	23.7	8.5	0.67	2,000	2,100	1,100
10,000	13,500	130.0	124.0	21.2	7.3	0.69	1,800	1,900	750
Freight RoRo Ships									CEU
50,000	87,500	287.0	273.0	32.2	12.4	0.78	7,500	7,800	5,000
45,000	81,500	275.0	261.0	32.2	12.0	0.79	6,850	7,100	4,500
40,000	72,000	260.0	247.0	32.2	11.4	0.77	6,200	6,400	4,000
35,000	63,000	245.0	233.0	32.2	10.8	0.76	5,600	5,800	3,500
30,000	54,000	231.0	219.0	32.0	10.2	0.74	5,100	5,300	3,000
25,000	45,000	216.0	205.0	31.0	9.6	0.72	4,600	4,800	2,500
20,000	36,000	197.0	187.0	28.6	9.1	0.72	4,250	4,400	2,000
15,000	27,500	177.0	168.0	26.2	8.4	0.73	3,750	3,900	1,500
10,000	18,400	153.0	145.0	23.4	7.4	0.71	3,100	3,200	1,000
5,000	9,500	121.0	115.0	19.3	6.0	0.70	2,200	2,300	600
Cargo Vessels									
40,000	54,500	209.0	199.0	30.0	12.5	0.71	3,250	4,500	
35,000	48,000	199.0	189.0	28.9	12.0	0.71	3,000	4,100	
30,000	41,000	188.0	179.0	27.7	11.3	0.71	2,700	3,700	
25,000	34,500	178.0	169.0	26.4	10.7	0.71	2,360	3,200	
20,000	28,000	166.0	158.0	24.8	10.0	0.70	2,100	2,800	
15,000	21,500	152.0	145.0	22.6	9.2	0.70	1,770	2,400	
10,000	14,500	133.0	127.0	19.8	8.0	0.70	1,380	1,800	
5,000	7,500	105.0	100.0	15.8	6.4	0.72	900	1,200	
2,500	4,000	85.0	80.0	13.0	5.0	0.75	620	800	
Note: Dimensions given in the tables may vary up to $\pm 10\%$ depending on construction and country of origin.									

Table C-1: Typical ship dimensions from ROM 3.1 (Continued)

DWT (t)	Δ_m (t)	L_{oa} (m)	L_{pp} (m)	B (m)	T (m)	C_B (-)	Min. Lateral Windage: Fully Loaded (m ²)	Max. Lateral Windage: In Ballast (m ²)	Approx. Capacity: CEU
Car Carriers									CEU
70,000	52,000	228.0	210.0	32.2	11.3	0.66	5,700	6,900	8,000
65,000	48,000	220.0	205.0	32.2	11.0	0.64	5,400	6,500	7,000
57,000	42,000	205.0	189.0	32.2	10.9	0.62	4,850	5,800	6,000
45,000	35,500	198.0	182.0	32.2	10.0	0.59	4,300	5,100	5,000
36,000	28,500	190.0	175.0	32.2	9.0	0.55	3,850	4,600	4,000
27,000	22,000	175.0	167.0	28.0	8.4	0.55	3,400	4,000	3,000
18,000	13,500	150.0	143.0	22.7	7.4	0.55	2,600	3,000	2,000
13,000	8,000	130.0	124.0	18.8	6.2	0.54	2,000	2,200	1,000
8,000	4,300	100.0	95.0	17.0	4.9	0.53	1,300	1,400	700
Ferries									
50,000	82,500	309.0	291.0	41.6	10.3	0.65	6,150	6,500	
40,000	66,800	281.0	264.0	39.0	9.8	0.65	5,200	5,500	
30,000	50,300	253.0	237.0	36.4	8.8	0.65	4,300	4,500	
20,000	33,800	219.0	204.0	32.8	7.8	0.63	3,300	3,500	
15,000	25,000	197.0	183.0	30.6	7.1	0.61	2,650	2,800	
12,500	21,000	187.0	174.0	28.7	6.7	0.61	2,450	2,600	
11,500	19,000	182.0	169.0	27.6	6.5	0.61	2,350	2,500	
10,200	17,000	175.0	163.0	26.5	6.3	0.61	2,200	2,300	
9,000	15,000	170.0	158.0	25.3	6.1	0.60	2,100	2,200	
8,000	13,000	164.0	152.0	24.1	5.9	0.59	1,900	2,000	
7,000	12,000	161.0	149.0	23.5	5.8	0.58	1,800	1,900	
6,500	10,500	155.0	144.0	22.7	5.6	0.56	1,700	1,800	
5,000	8,600	133.0	124.0	21.6	5.4	0.58	1,420	1,500	
3,000	5,300	110.0	102.0	19.0	4.7	0.57	950	1,000	
2,000	3,500	95.0	87.0	17.1	4.1	0.56	760	800	
1,000	1,800	74.0	68.0	14.6	3.3	0.54	570	600	
Fast Ferries (multihull)									
9,000	3,200	127.0	117.0	30.5	4.3	0.43	1,850	2,000	
6,000	2,100	107.0	93.0	26.5	3.7	0.43	1,550	1,650	
5,000	1,700	97.0	83.0	24.7	3.4	0.43	1,250	1,250	
4,000	1,400	92.0	79.0	24.0	3.2	0.42	1,120	1,200	
2,000	700	85.0	77.0	21.2	3.1	0.39	1,070	1,150	
1,000	350	65.0	62.0	16.7	2.1	0.37	820	900	
500	175	46.0	41.0	13.8	1.8	0.35	460	500	
250	95	42.0	37.0	11.6	1.6	0.35	420	450	
Note: Dimensions given in the tables may vary up to $\pm 10\%$ depending on construction and country of origin.									

Table C-1: Typical ship dimensions from ROM 3.1 (Continued)

DWT (t)	Δ_m (t)	L_{oa} (m)	L_{pp} (m)	B (m)	T (m)	C_B (-)	Min. Lateral Windage: Fully Loaded (m ²)	Max. Lateral Windage: In Ballast (m ²)	Approx. Capacity: Passengers
Cruise Liners (Post Panamax)									
220,000	115,000	360.0	333.0	55.0	9.2	0.67	15,700	16,000	5,400 / 7,500
160,000	84,000	339.0	313.6	43.7	9.0	0.66	13,800	14,100	3,700 / 5,000
135,000	71,000	333.0	308.0	37.9	8.8	0.67	13,100	13,400	3,200 / 4,500
115,000	61,000	313.4	290.0	36.0	8.6	0.66	11,950	12,200	3,000 / 4,200
105,000	56,000	294.0	272.0	35.0	8.5	0.67	10,800	11,000	2,700 / 3,500
95,000	51,000	295.0	273.0	33.0	8.3	0.67	10,400	10,600	2,400 / 3,000
80,000	44,000	272.0	231.0	35.0	8.0	0.66	8,800	9,000	2,000 / 2,800
Cruise Liners (Panamax)									
90,000	48,000	294.0	272.0	32.2	8.0	0.67	10,400	10,600	2,000 / 2,800
80,000	43,000	280.0	248.7	32.2	7.9	0.66	9,100	9,300	1,800 / 2,500
70,000	38,000	265.0	225.0	32.2	7.8	0.66	8,500	8,700	1,700 / 2,400
60,000	34,000	252.0	214.0	32.2	7.6	0.63	7,250	7,400	1,600 / 2,200
60,000	34,000	251.2	232.4	28.8	7.6	0.65	7,850	8,000	1,600 / 2,200
50,000	29,000	234.0	199.0	32.2	7.1	0.62	6,450	6,600	1,400 / 1,800
50,000	29,000	232.0	212.0	28.0	7.4	0.64	6,850	7,000	1,400 / 1,800
40,000	24,000	212.0	180.0	32.2	6.5	0.62	5,600	5,700	1,200 / 1,600
40,000	24,000	210.0	192.8	27.1	7.0	0.64	5,900	6,000	1,200 / 1,600
35,000	21,000	192.0	164.0	32.0	6.3	0.62	4,800	4,900	1,000 / 1,400
35,000	21,000	205.0	188.0	26.3	6.8	0.61	5,500	5,600	1,000 / 1,400
30,000	18,200	190.0	175.0	25.0	6.7	0.61	4,600	4,700	850 / 1,200
25,000	16,200	180.0	165.0	24.0	6.6	0.60	3,920	4,000	700 / 1,000
20,000	14,000	169.0	155.0	22.5	6.5	0.60	3,430	3,500	600 / 800
15,000	11,500	152.0	140.0	21.0	6.4	0.60	2,940	3,000	350 / 500
10,000	8,000	134.0	123.0	18.5	5.8	0.59	2,350	2,400	280 / 400
5,000	5,000	100.0	90.0	16.5	5.6	0.59	1,570	1,600	200 / 300
Ocean-going Fishing Vessels									
7,500	9,100	128.0	120.0	17.1	6.8	0.64	810	840	
5,000	6,200	106.0	100.0	16.1	6.2	0.61	650	670	
3,000	4,200	90.0	85.0	14.0	5.9	0.58	550	570	
2,500	3,500	85.0	81.0	13.0	5.6	0.58	500	520	
2,000	2,700	80.0	76.0	12.0	5.3	0.54	470	490	
1,500	2,200	76.0	72.0	11.3	5.1	0.52	430	450	
1,200	1,900	72.0	68.0	11.0	5.0	0.50	400	420	
1,000	1,600	70.0	66.0	10.5	4.8	0.47	380	400	
700	1,250	65.0	62.0	10.0	4.5	0.44	345	360	
500	800	55.0	53.0	8.6	4.0	0.43	290	300	
250	400	40.0	38.0	7.0	3.5	0.42	190	200	
150	300	32.0	28.0	7.5	3.4	0.41	135	140	
Note: Dimensions given in the tables may vary up to $\pm 10\%$ depending on construction and country of origin.									

Table C-1: Typical ship dimensions from ROM 3.1 (Continued)

DWT (t)	Δ_m (t)	L_{oa} (m)	L_{pp} (m)	B (m)	T (m)	C_B (-)	Min Lateral Windage Fully Loaded (m ²)		Max Lateral Windage In Ballast (m ²)	Approx. Capacity (m ³)
Coastal Fishing Vessels										
100	200	27.0	23.0	7.0	3.1	0.39				
75	165	25.0	22.0	6.6	2.8	0.40				
50	115	21.0	17.0	6.2	2.7	0.39				
25	65	15.0	12.0	5.5	2.6	0.37				
15	40	11.0	9.2	5.0	2.3	0.37				
Motor Yachts										
-	9,500	160.0	135.0	21.8	5.5	-				
-	7,000	140.0	120.0	23.5	5.0	-				
-	4,500	120.0	102.0	18.5	4.9	-				
-	3,500	100.0	85.0	16.5	4.8	-				
-	1,600	70.0	60.0	13.5	3.8	-				
-	1,100	60.0	51.0	12.0	3.6	-				
-	700	50.0	43.0	9.0	3.5	-				
-	500	45.0	39.0	8.5	3.3	-				
-	250	40.0	24.0	8.0	3.0	-				
-	150	30.0	25.0	7.5	2.9	-				
-	50	20.0	17.0	5.5	2.7	-				
Motor Boats										
-	35.0	21.0	-	5.0	3.0	-				
-	27.0	18.0	-	4.4	2.7	-				
-	16.5	15.0	-	4.0	2.3	-				
-	6.5	12.0	-	3.4	1.8	-				
-	4.5	9.0	-	2.7	1.5	-				
-	1.3	6.0	-	2.1	1.0	-				
Sailing Yachts										
	1,500	90.0	67.5	13.5	6.5	-				
	1,000	70.0	51.5	11.5	6.0	-				
	650	60.0	42.0	11.2	5.5	-				
	550	50.0	37.5	9.5	5.0	-				
	190	40.0	35.0	9.3	4.5	-				
	125	30.0	28.0	7.2	3.6	-				
	40	20.0	17.5	5.5	3.0	-				
	13	15.0	11.2	4.5	2.5	-				
Sailing Boats										
	10	12.0	11.0	3.8	2.3	-				
	5	10.0	9.5	3.5	2.1	-				
	1.5	6.0	5.7	2.4	1.5	-				
	1.0	5.0	4.3	2.0	1.0	-				
	0.8	2.5	2.3	1.5	0.5	-				
Note: Dimensions given in the tables may vary up to $\pm 10\%$ depending on construction and country of origin.										

Table C-1: Typical ship dimensions from ROM 3.1 (Concluded)

C.2 Japanese Statistical Analysis of Ship Dimensions

The Japanese Ministry of Land, Infrastructure, Transport and Tourism (2007) has performed extensive statistical analysis of the basic ship types from the Lloyd's Maritime Intelligence Unit Shipping Data (2004) and Lloyd's Register Fairplay Data (2006). For the eight ship types they analysed (cargo ships including bulk carriers, container ships, oil tankers, RoRo, PCC (Pure Car Carrier), LPG, LNG and passenger ships), they found that ship dimensions such as L_{oa} , L_{pp} , B , T , and H_{kt} are proportional to the 1/3 power of GT or DWT. They defined a 'coverage rate' (P), similar to confidence limits, to contain more of the maximum values of these ship dimensions. Additional information on H_{kt} is contained in Appendix F.

Table C-2 lists values of $P = 95\%$ for the 'weight' class of ships as a function of DWT and the 'volume' class of ships as a function of GT. The $P = 95\%$ coverage rate in Table C-2 implies that in repeated sampling from the population of all ships of this type and size, 95% will contain (less than or equal) the listed value of ship dimension, and by chance, only 5% will not (i.e. exceed this value). For example, for a 300,000 DWT oil tanker, the full load draught T equals 24.0 m for $P = 95\%$ coverage rate. Similarly, for a 100,000 GT passenger ship, the moulded breadth or beam B equals 33.5 m for $P = 95\%$ coverage. This example illustrates how these data should be considered with care since they are based on statistics and real ships would not necessarily have $B = 33.5$ m. Due to the Panama Canal restrictions, ships were not built in the beam range between 32.2 and 36 m for a long time. However, there are some ships with beams in this range and larger now. Interested readers may check Takahashi (2006) for $P = 75\%$ data.

Table C-2 is designed as a 'backup' and 'second opinion' for Table C-1 values. Although most of the sizes overlap, some do not, so it is useful to have access to both tables. The user should remember that Table C-1 values are based on real ship dimensions, whereas Table C-2 values are a statistical value based on many ships and do not necessarily represent as 'as-built' ship. Rather than trying to confuse users, it is our intent that users should use Table C-2 as a backup to Table C-1 and to look elsewhere if necessary. This is especially true as new generation vessels are continually being added to the world-wide fleet and will require additional research.

GT	L_{oa} (m)	L_{pp} (m)	B (m)	T (m)	H_{KT} (m)
Roll-on/Roll-off Ship					
5,000	137	120	24.0	7.0	40.2
7,000	154	136	26.0	7.8	42.8
10,000	174	155	28.2	8.8	45.5
15,000	200	179	30.9	10.0	48.6
20,000	222	199	33.0	11.0	50.7
40,000	204	179	32.3	9.9	56.0
50,000	217	201	32.3	9.9	57.7
60,000	217	201	32.3	9.9	59.1
Pure Car Carrier Ship					
5,000	119	98	19.0	6.4	37.3
7,000	132	112	20.5	7.0	39.9
10,000	147	128	22.1	7.7	42.6
15,000	166	150	24.2	8.6	45.7
20,000	181	167	25.8	9.3	47.8
30,000	205	196	28.2	10.4	50.9
40,000	192	182	33.4	10.0	53.1
50,000	214	204	32.4	11.2	54.8
60,000	214	204	32.4	11.2	56.2
LPG Ship					
5,000	123	116	19.9	8.4	37.0
7,000	137	129	21.9	9.3	39.4
10,000	153	145	24.3	10.3	41.9
15,000	174	165	27.3	11.5	44.8
20,000	191	181	29.6	12.5	46.9
30,000	217	206	33.3	14.0	49.8
50,000	255	243	38.5	16.2	53.4
60,000	270	258	40.5	17.1	54.7
LNG Ship					
5,000	116	108	18.8	6.6	
7,000	130	121	20.8	7.1	
10,000	146	137	23.2	7.7	
15,000	167	156	26.2	8.4	
20,000	183	172	28.6	9.0	
30,000	209	197	32.4	9.9	
50,000	247	234	37.8	11.1	
70,000	275	262	41.9	11.9	60.4
100,000	309	295	46.7	13.0	71.5
Passenger Ship					
5,000	137	129	23.4	7.2	43.0
7,000	153	144	25.3	8.1	46.0
10,000	173	162	27.5	9.1	49.1
15,000	199	186	30.2	10.4	52.7
20,000	220	204	32.3	8.9	55.2
30,000	253	234	35.6	8.9	58.8
50,000	302	277	33.5	8.9	63.4
70,000	339	309	33.5	8.9	66.3
100,000	383	348	33.5	8.9	69.5

DWT	L_{oa} (m)	L_{pp} (m)	B (m)	T (m)	H_{KT} (m)
Cargo Ship					
5,000	118	108	18.5	7.4	36.0
7,000	130	119	20.4	8.3	38.2
10,000	145	133	22.6	9.3	40.6
15,000	163	150	25.4	10.6	43.3
20,000	177	164	27.5	11.7	45.2
30,000	200	186	30.9	11.2	47.9
50,000	232	217	35.8	13.3	51.2
70,000	256	240	39.4	14.8	53.5
100,000	285	268	43.6	16.6	55.8
150,000	321	303	48.9	18.9	58.5
200,000	349	330	53.1	20.8	60.4
300,000	394	373	59.6	23.7	63.1
Container Ship					
5,000	116	107	18.9	6.7	39.4
7,000	130	121	20.9	7.4	42.3
10,000	147	137	23.3	8.3	45.4
15,000	170	158	26.3	9.5	49.0
20,000	187	175	28.7	10.4	51.5
30,000	216	203	32.4	11.9	55.0
50,000	294	276	34.4	13.2	59.4
70,000	293	281	44.0	14.5	62.3
100,000	361	342	43.2	14.9	65.4
Oil Tanker					
5,000	108	103	18.8	7.2	
7,000	118	115	20.5	8.0	
10,000	144	135	21.6	8.8	
15,000	159	150	24.6	9.8	
20,000	171	161	26.9	10.7	
30,000	190	179	30.6	11.9	
50,000	216	204	36.0	13.8	44.1
70,000	235	223	40.1	13.8	48.9
100,000	258	244	44.9	15.8	53.9
150,000	286	271	51.0	18.5	59.7
200,000	339	326	61.0	20.6	63.8
300,000	339	326	61.0	24.0	69.6

Table C-2: Ship dimensions [Takahashi, 2006] as a function of $P = 95$ % coverage rate

C.3 Relationship Between DWT and H_{kt}

Table C-2 shows relationships between DWT and H_{kt} , but only for a limited data set for container ships from the earlier Japanese research. This section presents a least square fit of the existing Japanese data in Table C-2 so that it can be extrapolated for newer, larger container ships to 250,000 DWT. The data to DWT = 100,000 was extrapolated using a natural log (ln) function with R^2 correlation coefficient of 1.0. The corresponding H_{kt} = 68.9, 71.4, and 73.4 m for DWT = 150,000, 200,000 and 250,000 respectively.

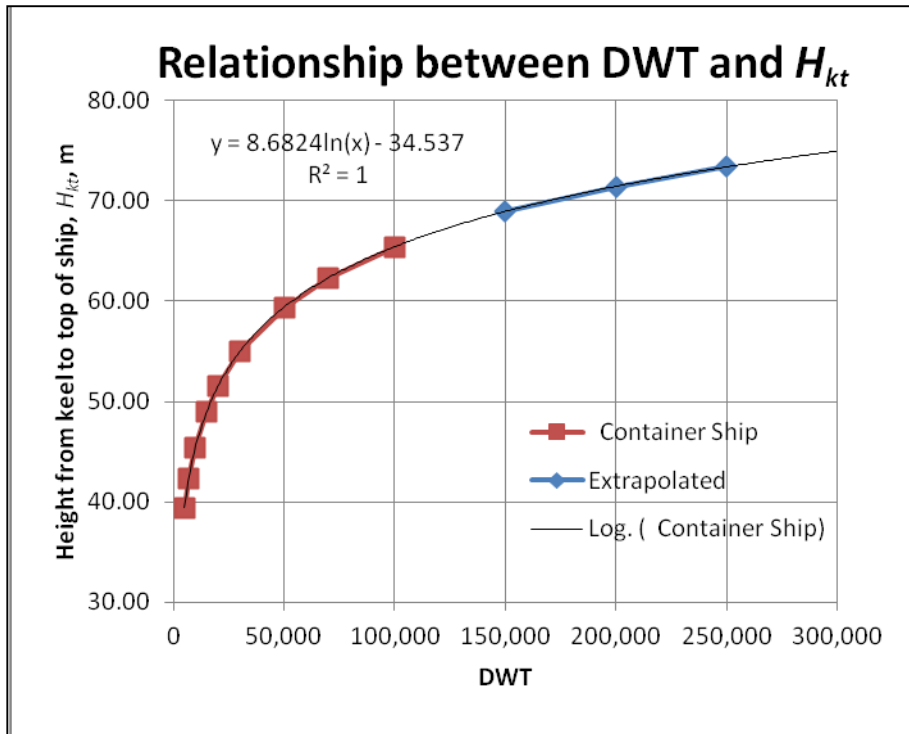

Figure C-2: Relationship between DWT and H_{kt} for container ships

C.4 Relationship Between C_B , Δ , Δ_m and ∇

The values of C_B in this appendix are based on the mass displacement for seawater Δ_m (kg or tonnes), or the weight displacement for seawater Δ (N or kN). The relationship between the volume displacement ∇ (m^3) and the density of seawater ρ_{sw} and gravity g is given by:

$$C_B = \frac{\Delta}{\rho_{sw} g L_{pp} B T} = \frac{\Delta_m}{\rho_{sw} L_{pp} B T} = \frac{\nabla}{L_{pp} B T} \quad (\text{C-1})$$

Note that ρ_{sw} is a function of water temperature with a typical value of 1.025 t/m^3 at a temperature of 20 deg C.

C.5 Relationship Between Ship's Draught and Water Density

This dependence can be useful in determining the ship's draught in fresh T_{fw} and seawater T_{sw} as a function of the block coefficient C_B and the water plane area coefficient C_{WP} that is equal to:

$$T_{fw} = \left(1 + 0.025 \frac{C_B}{C_{WP}} \right) T_{sw} \approx 1.02 \text{ to } 1.025 T_{sw} \quad (\text{C-2})$$

and C_{WP} is defined in Appendix D, equation D-1. Note that the latter equivalence in equation C-2 is only valid for conventional displacement ships. Catamarans and semi-submersibles require the use of the first part of equation C-2.

The formula given in (C-2) is correct if the ship is even keel in both sea water and fresh water. When a ship passes from one water density to another, the mean draught will change due to the change in water density and the trim can change due to a change in the position of the centre of buoyancy relative to the centre of gravity and the centre of flotation. Ships, especially container ships, experience this phenomenon. Due to this trim, the draught increase (either fore or aft) will be larger. Likewise, a ship departing a fresh water harbour in even keel condition will experience a smaller draught decrease due to this trim. In general, the amount of this draught increase or decrease is relatively small (usually less than 10 cm) compared to the other uncertainties in deep-draught channel design. Additional details on this effect are described in Rawson and Tupper (2001).

C.6 Japanese Metacentric Height Estimates

Table C-3 [Tsugane, 2009] lists ranges of calculated $\overline{GM} / T_{Design}$ ratios for several ship types as a function of the maximum design draught T_{Design} for each ship. Multiply these ratios by T_{Design} to obtain an estimate of GM .

Ship Type		$\overline{GM} / T_{Design}$
Bulkers	Capesize	0.30 to 0.40
	Panamax	0.25 to 0.30
	Post-Panamax	0.50 to 0.60
Container ship	Panamax	0.05 to 0.10
	Post-Panamax	0.10 to 0.15
Pure Car Carrier	Panamax	0.10 to 0.15
Tanker	Spherical/Moss LNG	0.25 to 0.35
	Prismatic/Membrane LNG	0.20 to 0.30
	VLCC	0.30 to 0.40
Notes: <ul style="list-style-type: none"> • T_{Design} = Maximum design draught (m). • PCC = Pure Car Carrier. • VLCC = Very Large Crude Carrier. 		

Table C-3: Metacentric height estimates $\overline{GM} / T_{Design}$ for range of ship types [Tsugane, 2009]

C.7 References

See Chapter 5 for list of references.

9 APPENDIX D PREDICTION OF SHIP SQUAT

D.1 Ship Characteristics

D.1.1 Dimensionless Parameters

Figure D-1 is a schematic of a ship illustrating the main ship dimensions required for squat predictions: length between perpendiculars L_{pp} , beam B , and draught T . The L_{pp} is measured between the forward FP and aft AP perpendiculars, and is used as an approximation to the L_w , which is the vessel length at the waterline. These three dimensions are often combined into three dimensionless ratios. The vessel length to beam ratio L_{pp}/B has typical values from 5 to 9. The vessel length to draught ratio L_{pp}/T has typical values from 15 to 25. Finally, the vessel beam to draught ratio B/T has typical values from 2 to 5.

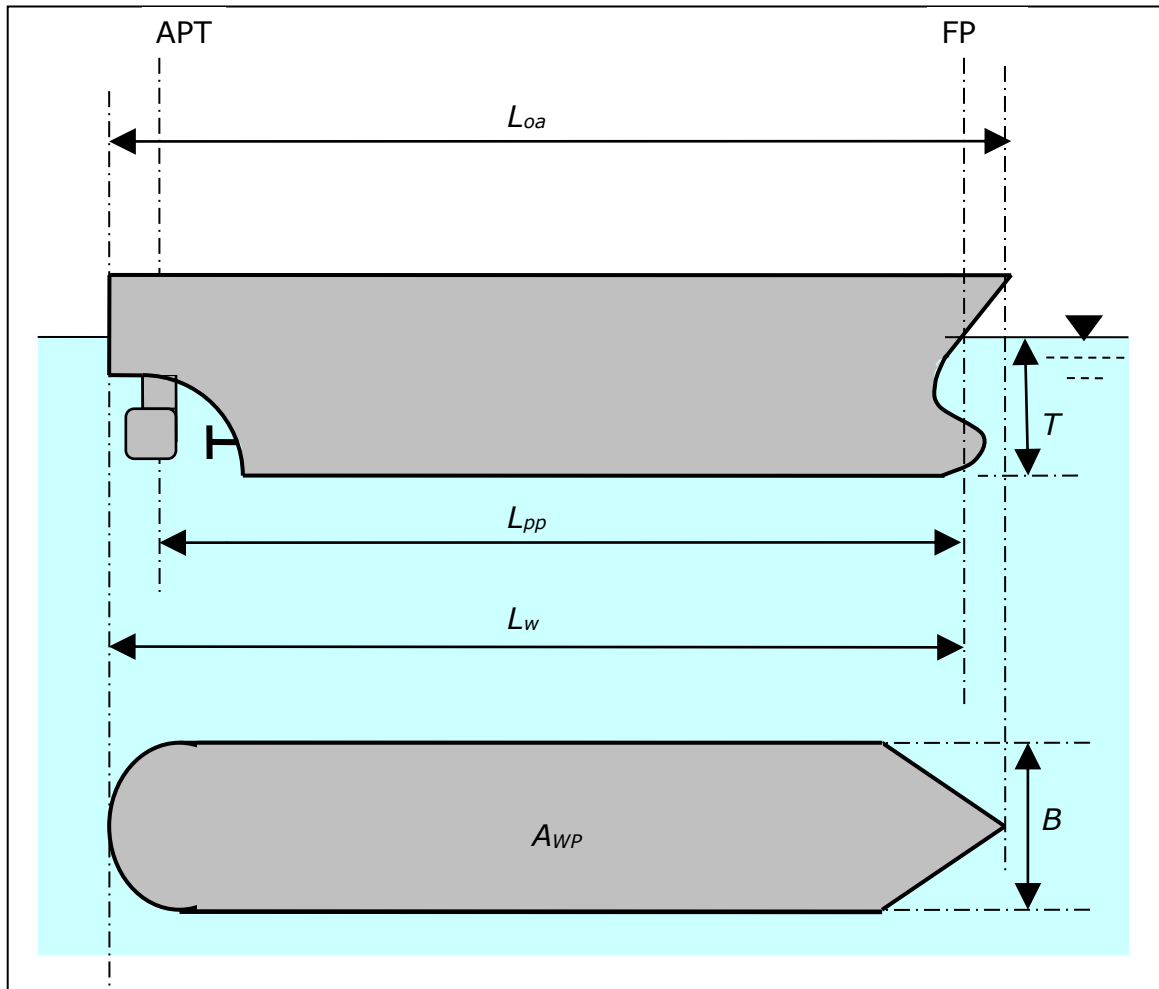

Figure D-1: Ship parameters

D.1.2 Block Coefficient

The block coefficient C_B is often used to describe the hull form or overall ship shape. The C_B is a measure of the ‘fineness’ of the vessel’s shape relative to an equivalent rectangular volume with the same dimensions. Typical values of C_B range from 0.36 to 0.45 for high-speed vessels to 0.85 for slow, full-size tankers and bulk carriers. Container ships are more slender and typically have C_B values in the range from 0.54 to 0.71. In general, a bulky oil tanker will have comparatively more squat than a more slender container ship for the same speed. For partial load conditions, the Spanish ROM recommends using a constant C_B for all ‘weight’ class ships (see Chapter 1). For ‘volume’ class ships (Chapter 1), use constant C_B up to a 60 % reduction in load and then reduce it by 10 % to account for the change in underwater hull shape due to the reduced load. Additional data for C_B is contained in Appendix C ‘Typical Ship Dimensions’ in Table C-1. For Concept Design, the C_B values in Table C-1 are recommended. For Detailed Design, the C_B should be calculated using Eq. C-1 with real ship data.

D.1.3 Water Plane Cross-Sectional Area

The water plane coefficient C_{WP} is another ratio that is used to describe the hull form or overall ship shape. It is based on the area of the vessel’s water plane cross-section A_{WP} (Figure D-1) and is defined as:

$$C_{WP} = \frac{A_{WP}}{L_{pp}B} \quad (D-0)$$

Again, the C_{WP} is less than 1.0 because the actual cross-sectional area A_{WP} is divided by an equivalent rectangular area. Typical values are from 0.75 to 0.85 [Gaythwaite, 1990], although a value as large as 0.90 has been used for larger tankers and bulk carriers. The C_{WP} is not used as often now since formulas involving the simpler C_B are easier to use and require one less variable. In fact, Barrass (1979) formulated a value for C_{WP} based on C_B approximated as:

$$C_{WP} \approx \frac{1}{3}(2C_B + 1) \quad (D-0)$$

D.1.4 Ship Speed

Squat increases with speed for a given water depth. Ship speed is given by V_s in m/s and V_k in knots. The ship speed is speed relative to the water (not over ground), so that fluvial currents and tidal currents must be taken into account. Values of V_k greater than 6 knots are usually necessary to produce any significant squat.

D.1.5 Calculated Ship Parameters

Calculated ship parameters include the ship’s volume displacement ∇ (m³) and underwater midships cross-sectional area A_S (Figure D-2). The ∇ is defined as:

$$\nabla = C_B L_{pp} B T \quad (D-0)$$

Appendix C (Eq. C-1) shows the relationship between volume displacement ∇ and the weight displacement Δ (mt). The $A_S = 0.98BT$ is generally given to account for the keel radius, although some researchers use $A_S = BT$ since the error is small relative to other uncertainties.

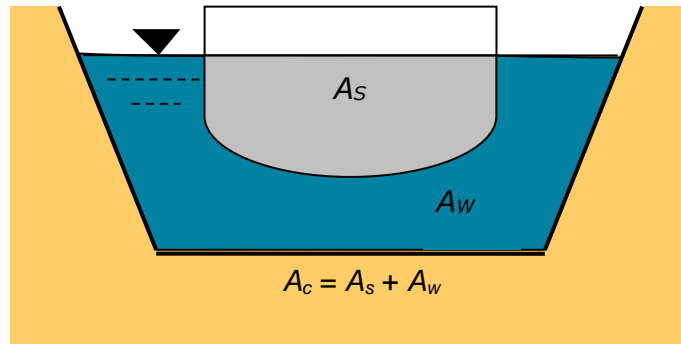

Figure D-2: Ship and channel cross-sectional area definition

D.2 Channel Characteristics

D.2.1 Channel Types

Historically, three idealised types of navigation channels have been defined for squat applications:

- Unrestricted or open (U)
- Restricted, confined, or trenched (R)
- Canal (C).

Figure D-3 is a schematic of these three types of navigation channels. Unrestricted-type channels are in larger open bodies of water and toward the offshore end of navigation channels. The restricted channel, with a dredged underwater trench, is probably the most typical type of channel. Canal-type channels are usually man-made inland channels with sides that extend above the water surface. Many channels can be characterized by two or three of these channel types as the different segments or reaches of the channel have different cross sections. They are somewhat idealised as real channels are rarely symmetric with equivalent sides.

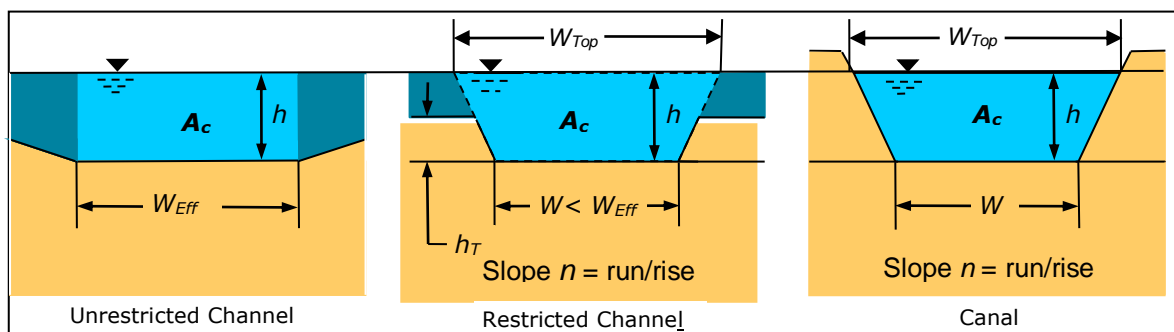

Figure D-3: Channel configurations: unrestricted (open), restricted (trench) and canal

D.2.2 Channel Parameters

Important channel parameters used to describe these three types of navigation channels are the width at the bottom of the channel W , projected width at the top of the channel W_{Top} , water depth h , mean water depth h_M , restricted channel water depth h_{mT} , trench height h_T measured from the bottom of the channel to the top of the trench, side slope n , and cross-sectional area A_C . Table D-1 indicates which parameters are necessary to describe each channel configuration.

Parameter	Symbol	Channel Type		
		Unrestricted U	Restricted R	Canal C
Width input				
Channel width	W	--	Input	Input
Effective width	W_{Eff}	Calculated	--	--
Projected width at top	W_{Top}	--	Calculated	Calculated
Depth input				
Water depth	h	Input	Input	Input
Mean water depth	h_M	--	Calculated	Calculated
Restricted water depth	h_{mT}	--	Calculated	--
Height of trench	h_T	--	Input	--
Slope input				
Inverse bank slope	n	--	Input	Input
Cross-sectional area	A_C	Calculated	Calculated	Calculated

Table D-1: Channel parameters

Since an unrestricted (open) channel has no channel width W , an effective channel width W_{Eff} needs to be defined to determine if a channel qualifies as an unrestricted channel cross-section. Most researchers have required W_{Eff} values equal to $8B$ for unrestricted channels, with finer form vessels requiring as much as $12B$. Originally, Barrass (1979) developed an empirical formula for W_{Eff} based on B and the waterplane coefficient C_{WP} . In 2002, he simplified this formula by making it a function of B and C_B . His latest effort [Barrass, 2004] resulted in a formula for the 'width of influence' F_B as the artificial side boundary on both sides of the moving ship where the ship will experience changes in performance and resistance that affect squat, propeller RPMs, and speed. It is defined for h/T values from 1.10 to 1.40 for unrestricted water configurations as:

$$F_B = W_{Eff} = \left[\frac{7.04}{C_B^{0.85}} \right] B \quad (D-0)$$

If we use ranges of C_B from Appendix C, mean values of F_B are of the order of $8.1B$ to $8.9B$ for tankers and bulkers (C_B range from 0.85 to 0.76), $8.6B$ to $9.4B$ for general cargo ships (C_B range from 0.79 to 0.71), and $9.4B$ to $10.7B$ for container ships (C_B range from 0.71 to 0.61). Of course, some outer channels have very gentle side slopes (i.e. 1:10 or gentler), so that even if the width is less than the W_{Eff} , the channel could still be considered as an Unrestricted channel.

The side slope is the inverse of the bank slope n (i.e. $n = \text{horizontal run/vertical rise} = \text{atan } \theta = 1/\tan \theta$). The value of n , although not necessarily an integer, typically has a value such as $n = 3$ representing side slopes of 1:3 (rise:run). However, values steeper (smaller number than 3) and flatter (larger number than 3) are possible. The unprotected underwater banks of a dredged trench depend on bottom material (e.g. fine or coarse

sand) and its stability against current, waves and ship actions. Canal banks are usually steeper and need bank revetment.

The projected channel width at the top of the channel W_{Top} (m) is used for canals and restricted channels and is given by:

$$W_{Top} = W + 2nh \quad (D-0)$$

Finally, the calculated cross-sectional area A_C (see Figure D-3) is the wetted cross-section of the canal or the equivalent wetted area of the restricted channel by projecting the slope to the water surface. It is given by:

$$A_C = Wh + nh^2 \quad (D-0)$$

For an unrestricted channel, use F_B for channel width W and set $n = 0$.

The mean water depth h_M (m) is a standard hydraulic parameter that is only required for canals and restricted channels. It is defined as:

$$h_M = \frac{A_C}{W_{Top}} \quad (D-0)$$

The relevant water depth h_{mT} (m) for restricted channels is a function of h , h_M and h_T and is defined as:

$$h_{mT} = h - \frac{h_T}{h}(h - h_M) \quad (D-0)$$

D.3 Combined Ship and Channel Parameters

Several dimensionless parameters are required in the squat prediction formulas that are ratios of both ship and channel parameters. They include relative draught ratio h/T , blockage factor S , velocity return factor S_2 , depth Froude Number F_{rh} and critical speed in canals V_{Cr} .

D.3.1 Relative Depth Ratio h/T

The water depth to draught ratio h/T is a measure of the relative depth of the channel. A 'Rule of Thumb' is to use a minimum value of 1.1 to 1.15 in calm water and 1.15 to 1.4 when waves are present. However, these h/T values can be slightly smaller or significantly larger (see Concept Design, Chapter 2). In general, ships experience more squat when h/T values are smaller since the ship 'feels' the bottom more. However, ship dimensions, speed and channel type also have a significant effect on the squat.

D.3.2 Blockage Factor S

The blockage factor S is the fraction of the cross-sectional area of the waterway A_c that is occupied by the ship's underwater midships cross-section A_s defined as (Figures D-2 and D-3):

$$S = \frac{A_s}{A_c} \quad (D-0)$$

Typical S values can vary from 0.10 to 0.3 or larger for restricted channels and canals, and 0.10 or less for unrestricted channels [USACE 2004 ; Barrass 2004]. The value of S is a factor in the calculation of the ship's critical speed in canals and restricted channels.

D.3.3 Velocity Return Factor S_2

The velocity return factor S_2 is similar to S except that it is the ratio between the ship's cross-sectional area A_s and the net cross-sectional area of the waterway A_w (Figure D-2) defined as:

$$S_2 = \frac{A_s}{A_w} = \frac{A_s}{A_c - A_s} = \frac{S}{1 - S} \quad (D-0)$$

where A_w is the difference between the channel cross-sectional area A_c and the ship cross-sectional area A_s .

D.3.4 Depth Froude Number F_{nh}

The **most important** dimensionless parameter is the depth Froude Number F_{nh} , which is a measure of the ship's resistance to motion in shallow water. The dimensionless F_{nh} is defined as:

$$F_{nh} = \frac{V_s}{\sqrt{gh}} \quad (D-0)$$

where g is gravitational acceleration (m/s^2) and V_s and h have been previously defined.

The F_{nh} expresses the ship's speed as a fraction of a critical value \sqrt{gh} , which is the maximum velocity of a disturbance propagating in a free surface of unrestricted shallow water with depth h . As the ship's resistance increases significantly for values of F_{nh} approaching unity, conventional (displacement) ships usually do not have sufficient power to overcome F_{nh} values of 0.6 for tankers or 0.7 for container ships. Most of the empirical equations require that F_{nh} be less than 0.7. For all cases, the value of F_{nh} should satisfy $F_{nh} < 1$, an effective speed barrier.

D.3.5. Critical Speed in Canals V_{Cr}

The motion of a ship with speed V_s in a restricted channel or canal with blockage factor S will cause a return flow. As a result, the water level will drop due to Bernoulli's Law, which causes a further reduction of the net cross-sectional area of the waterway and, hence, an amplification of the return flow and the water level sinkage. Due to this effect, a ship's squat will increase more than as a quadratic function of the ship's speed.

A stationary solution for the return flow and the sinkage is only possible for ship speeds not exceeding a critical speed V_{Cr} which is the solution to:

$$\frac{V_{Cr}}{\sqrt{gh_M}} = \left[\frac{2}{3} \left(1 - S + \frac{V_{Cr}^2}{2gh_M} \right) \right]^{1.5} \quad (D-0)$$

Note that V_{Cr} is on both sides of this equation. An explicit solution of this equation is given by:

$$\frac{V_{Cr}}{\sqrt{gh_M}} = K_c = \left[2 \sin \left(\frac{\arcsin(1-S)}{3} \right) \right]^{-1.5} = \left[2 \cos \left(\frac{\pi}{3} + \frac{\arccos(1-S)}{3} \right) \right]^{-1.5} \quad (D-0)$$

As shown in Figure D-4, K_c equals 1 and the critical speed equals $\sqrt{gh_M}$ (with limiting value of \sqrt{gh}) in unrestricted shallow water ($S = 0$), but decreases very rapidly with increasing blockage S . For example, a very small $S = 0.03$ results in a value of about $V_{Cr} \approx 0.8\sqrt{gh_M}$. Finally, Römisch presents additional details on the use of critical speed in all three channel types in D.4.6.

It should be noted that Eq. D-13 is only a (two-dimensional) approximation. This may explain deviations that have been observed with experimental results by Eloit et al. (2008), who have formulated an alternative expression for Eq. D-13 making use of a correction factor depending on ship geometry. The interested reader should consult with this paper.

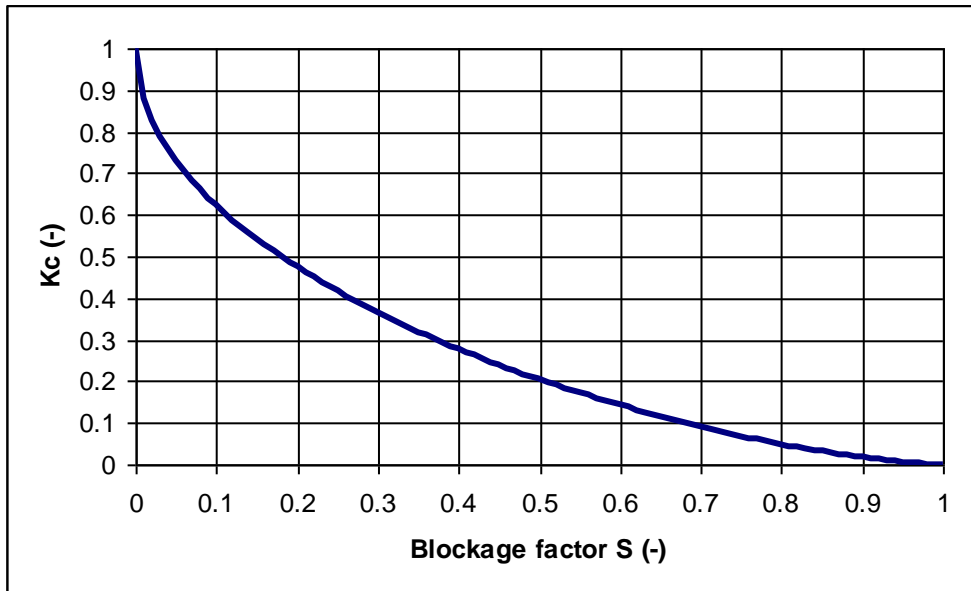

Figure D-4: K_c vs. Blockage factor S for canal

D.4 Empirical Squat Formulas

Seven empirical formulas for maximum squat S_{Max} have been proposed based on physical model tests and field measurements for different channels, ships and loading characteristics. All include sinkage and dynamic trim as part of the ship squat calculation. The Tuck formula is reported first since it is the basis for most of the other squat formulas. Next, the Huuska and ICORELS formulas are grouped with Tuck since they have a similar formula and reflect some of the pioneering research in this field. The remaining formulas are listed in alphabetical order, in no particular order of significance, for the reader's convenience. All are based on the metric system of units, although Barrass use ship speed in knots instead of m/s. Since these are mainly empirical formulas, they are not necessarily non-dimensional. Dimensions are therefore not necessarily consistent with constants sometimes used to account for unit conversions.

- Tuck (1966)
- Huuska/Guliev (1976)
- ICORELS (1980)
- Barrass3 (2004)
- Eryuzlu2 (1994)
- Römisch (1989)
- Yoshimura (1986).

Several other formulas are available for predicting ship squat, but are not included here since they either have been replaced with newer versions or are considered too complicated for most users. The formulas included the pioneering work of Tuck (1966), Tuck and Taylor (1970) and Beck et al. (1975); and early research by Guliev (1971, 1973), Hoofft (1974), Dand (1975), Huuska (1976), Eryuzlu and Hausser (1978), Römisch (1989), Millward (1990, 1992) and Norrbin (1986). The early work of Barrass (1979, 1981) has been replaced by his later works in 2002 and 2004. Barrass's work in 2007 is similar to the formula used in this report, so it was not included. The work of Eryuzlu and Hausser (1978) has been superseded by the later work of Eryuzlu in 1994. The St Lawrence Seaway is an active area of research by the Canadian Coast Guard to improve Eryuzlu's formulas [Stocks et al. 2002 ; Beaulieu et al. 2009]. Hoofft's (1974) formula is not included since it is similar to the Huuska/Guliev and ICORELS formulas.

Ankudinov and Daggett (2000) proposed the MARSIM (Maritime Simulation and Ship Manoeuvrability) 2000 formula for maximum squat based on a midpoint sinkage and vessel trim in shallow water. It is one of the most thorough, but also the most complicated formulas for predicting ship squat. Briggs and Daggett (2009), and Briggs et al. (2011, 2013) compared the Ankudinov MARSIM squat predictions with PIANC predictions for BAW (Bundesanstalt für Wasserbau) laboratory and Panama Canal measurements with good results. The Tohill (1966) formula is similar to the MARSIM 2000 formula, although not as complicated.

Historically, maximum squat occurred at the bow S_b , especially for full-form ships such as tankers. In very narrow channels or canals and for high-speed (fine-form) ships such as passenger liners and container ships, maximum squat sometimes occurs at the stern S_s . Barrass had proposed that the location of maximum ship squat at the bow or stern was mainly due to the block coefficient C_B . He stated that a ship with $C_B < 0.7$ that are typical of container ships would squat by the stern and a ship with $C_B > 0.7$ typical of bulkers and tankers would squat by the bow. The $C_B = 0.7$ is an 'even keel' situation with maximum squat the same at both bow and stern. Although this threshold value may not be accurate for all ship types, it is still a good reasonable 'rule of thumb'. An equivalent 'rule of thumb' on the location of the maximum squat is given by Römisch since a ship will squat by the bow if $C_B > 0.1 L_{pp}/B$. Appendix C contains listings of C_B in Tables C-1 and C-3.

All the PIANC formulas give predictions of maximum squat S_{Max} at the bow or stern, but only Römisch gives predictions explicitly for bow S_b and stern squat S_s for all channel types. Barrass also gives S_s for unrestricted channels and for canals and restricted channels depending on the value of C_B . Of course, for channel design, one is mainly interested in the maximum squat and not necessarily whether it is at the bow or stern.

The initial or static trim of the ship may influence the location of the maximum squat. According to Barrass (1995) for ships with large initial trim, the ship will always experience maximum squat in the same direction as this static trim and that dynamic trim would not change from the initial trim (i.e. if trimmed by the bow, dynamic trim would also be by the bow, etc.). However, recent German research [Härting et al. 2009 ; Reinking et

al., 2009] indicates that dynamic trim is a function of mean draught and initial or static trim. This conclusion is based on extensive field measurements of Post-Panamax container ships and bulkers on the River Weser and River Elbe in Germany. The German research also noted that a ship could start with a static trim to the bow or stern and end up with opposite dynamic trim. Most of the German measurements were for ships with newer transom sterns that are wider than previous generation ships so that this increased buoyancy as the ship trims to the stern could be affecting the ultimate dynamic trim back to the bow. The German research is ongoing.

The PIANC recommends that channels be designed in two stages: Concept and Detailed Design. In Chapter 2, squat was not explicitly calculated in the Concept Design stage as it was included in the empirical coefficients. However, if simplicity and ease of use are the guiding concerns in either design stage, then the ICORELS, Barrass3 and Yoshimura are certainly the first choices. The more complicated formulas of Huuska/Guliev, Eryuzlu2, Römisch, and Tuck are the best choices for the Detailed Design stage. Of course, any of the formulas could be used in either stage, as the accuracy is not necessarily improved as they become more difficult to use. In the Detailed Design phase, it is usually good practice to evaluate the squat with several of the formulas and calculate some statistics such as average and range of values. In some cases, the maximum squat values might be used in design for the case of dangerous cargo and/or hard channel bottoms. Briggs (2006) developed a FORTRAN program to predict squat using all the formulas considering the constraints and limitations, and gives some basic statistical data. A similar FORTRAN program was written and documented by Briggs (2009a) for the Ankudinov MARSIM squat predictions.

Table D-2 is a summary of the applicable channel configurations and parameter constraints according to the individual testing conditions. Some of these constraints are very restrictive (especially for the newer vessels coming on line) as they are based on the limited set of conditions tested in physical models by the individual researchers. This does not mean that the particular formula would not be applicable if the constraints are exceeded by a reasonable amount. Designers should be careful about speeds used in their design as these formulas were developed for a specific range of speeds. Therefore, if the constraints are exceeded, the user should use *engineering judgment* when deciding the applicability of those predictions.

D.4.1 Tuck (T)

The first empirical squat formula is the basis for many of the empirical ship squat prediction formulas and was developed by Tuck (1966) using slender body potential theory. Tuck and Taylor (1970) made some approximations for infinite width shallow water (i.e. unrestricted channel) conditions. It is abbreviated with the subscript 'T' and the bow squat S_{bT} (m) is given by:

$$S_{bT} = (C_Z + C_\theta) \frac{\nabla}{L_{pp}^2} \frac{F_{nh}^2}{\sqrt{1 - F_{nh}^2}} \quad (D-0)$$

where C_Z and C_θ are coefficients based on the ship hull characteristics for mean sinkage and trim, respectively. Unfortunately, these coefficients are based on integrals and not easy to apply. The Tuck formula introduced 'critical speed' in the last term $F_{nh}^2 / \sqrt{1 - F_{nh}^2}$ in Eq. D-14. The critical speed corresponds when $F_{nh} = 1$ in this 'Tuck Factor'.

Code ID	Configuration			Constraint							
	U	R	C	F_{nh}	C_B	S	B/T	h/T	h_T/h	L/B	L/T
Tuck (1966)	Y	Y	Y	F_{nh}^{2+}							
Huuska/Guliev (1976)	Y	Y	Y	≤ 0.7	0.6 - 0.8		2.19 - 3.5	1.1 - 2.0	0.22 - 0.81	5.5 - 8.5	16.1 - 20.2
ICORELS (1980)	Y	(Y)		≤ 0.7 V_{Cr}	0.6 - 0.8		2.19 - 3.5	1.1 - 2.0	0.22 - 0.81	5.5 - 8.5	16.1 - 20.2
Barrass3 (2004)	Y	Y	Y	V^2	0.5 - 0.85	0.1 - 0.25		1.1 - 1.4			
Eryuzlu2 (1994)	Y	Y		F_{nh}^{2+}	≥ 0.8		2.4 - 2.9	1.1 - 2.5		6.7 - 6.8	
Römisch (1989)	Y	Y	Y	V^{2+} , V_{Cr}			2.6	1.19 - 2.25		8.7	22.9
Yoshimura (1986)	Y	Y	Y	V^2	0.55 - 0.8		2.5 - 5.5	≥ 1.2		3.7 - 6.0	

Notes:

1. Y=Yes
2. Only h/T enforced for Römisch formula.
3. Only Barrass3 and Römisch predict stern squat S_S explicitly. Others predict maximum squat, whether at bow or stern.
4. V^2 : Squat a function of square of velocity
5. V^{2+} : Squat a function of more than square of velocity
6. F_{nh}^{2+} : Squat a function of more than square of F_{nh} .
7. V_{Cr} : Squat a function of critical speed V_{Cr} .
8. ICORELS sometimes used in Restricted channel although originally developed for Unrestricted.

Table D-2: Channel configurations and parameter constraints for squat formulas

Stocks et al. (2002) recommended the Tuck formula for the Lakers and Bulklers in the Lake St. Louis section (unrestricted channel) of the St. Lawrence Seaway (SLS). They reported a version of the Tuck formula as:

$$S_{br} = 1.46 \frac{\nabla}{L_{pp}^2} \frac{F_{nh}^2}{\sqrt{1-F_{nh}^2}} K_S + 0.5L_{pp} \sin \left\{ \frac{\nabla}{L_{pp}^3} \frac{F_{nh}^2}{\sqrt{1-F_{nh}^2}} K_S \right\} \quad (D-0)$$

where K_S is a correction factor for channel width for all three channel types that is described in the next section for Huuska/Guliev.

D.4.2 Huuska/Guliev (H)

Hooff (1974) combined Tuck's (1966) separate formulations for squat from sinkage and trim in unrestricted channels to a more useful format. In 1976 Huuska (abbreviated 'H') extended Hooff's work for unrestricted channels to include restricted channels and canals by adding a correction factor for channel width K_S that Guliev (1971, 1973) had developed. Their bow squat S_{bH} (m) is defined as:

$$S_{bH} = C_S \frac{\nabla}{L_{pp}^2} \frac{F_{nh}^2}{\sqrt{1-F_{nh}^2}} K_S \quad (D-0)$$

where ∇ is the displacement volume (see Appendix C, m^3), and L_{pp} and F_{nh} have been previously defined. The squat constant $C_S = 2.40$ is typically used as an average value in this formula, although Hooff had originally used $C_S = 1.96$, with values from $C_S = 1.9$ to

2.03 sometimes used. The factor ∇/L_{pp}^2 is equivalent to $C_B BT/L_{pp}$ and can be used interchangeably in squat equations. In general, this formula should not be used for F_{nh} greater than 0.7.

The dimensionless K_s for all three channel types is determined from:

$$K_s = \begin{cases} 7.45s_1 + 0.76 & s_1 > 0.03 \\ 1.0 & s_1 \leq 0.03 \end{cases} \quad (D-0)$$

with a dimensionless corrected blockage factor s_1 defined as:

$$s_1 = \begin{cases} 0.03 & \text{U} \\ \frac{S}{K_1} & \text{R} \\ S & \text{C} \end{cases} \quad (D-0)$$

Figure D-5 illustrates the behaviour of K_s versus s_1 in this equation. Note that $K_s = 1.0$ at $s_1 = 0.03$ for both ranges of s_1 in Eq. D-17.

The correction factor K_1 (Eq. D-18) is a function of normalized trench height ratios h_T/h provided by Huuska (Figure D-6) as a function of S for $0.2 \leq h_T/h \leq 1.0$. Huuska intended for K_1 to equal approximately 1.0 for $S \leq 0.03$ since the channel was essentially an unrestricted type for such a small blockage factor. Briggs (2006) had originally prepared a least squares polynomial fit of K_1 versus S assuming the y-intercept for K_1 was 1.0 at $S = 0$. The least squares coefficients were revised [Briggs, 2013] for a better fit of $K_1 = 1.0$ at $S \leq 0.03$. Table D-3 lists the revised Correlation Coefficient R^2 and the polynomial coefficients for each of the h_T/h curves. These coefficients can be used to program the equation for K_1 instead of approximating it visually from the graph in Figure D-6. This is convenient if performing multiple calculations for K_1 . The visually measured points from Huuska's Figure C6 [PIANC, 1997] are included in this table for reference. Note that for Canals (i.e. "C"), $s_1 = S$ as $K_1 = 1$ since $h_T/h = 1$.

The Finnish Maritime Administration (FMA) uses the Huuska/Guliev formula for all three channel configurations. They also include some additional constraints for lower and upper limits as follows (these were included in Table D-2 for the parameter constraints):

- C_B 0.60 to 0.80
- B/T 2.19 to 3.50
- L_{pp}/B 5.50 to 8.50
- h_T/h 0.22 to 0.81

The Spanish ROM (2003) also recommends the use of the Huuska/Guliev formula for all three channel configurations.

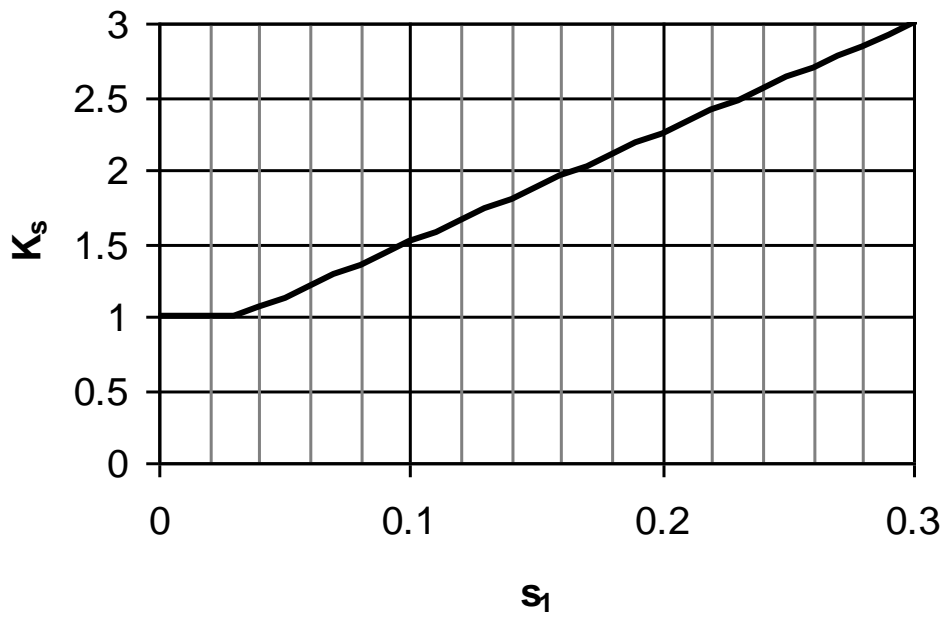

Figure D-5: Huuska/Guliev correction factor K_s vs. s_1

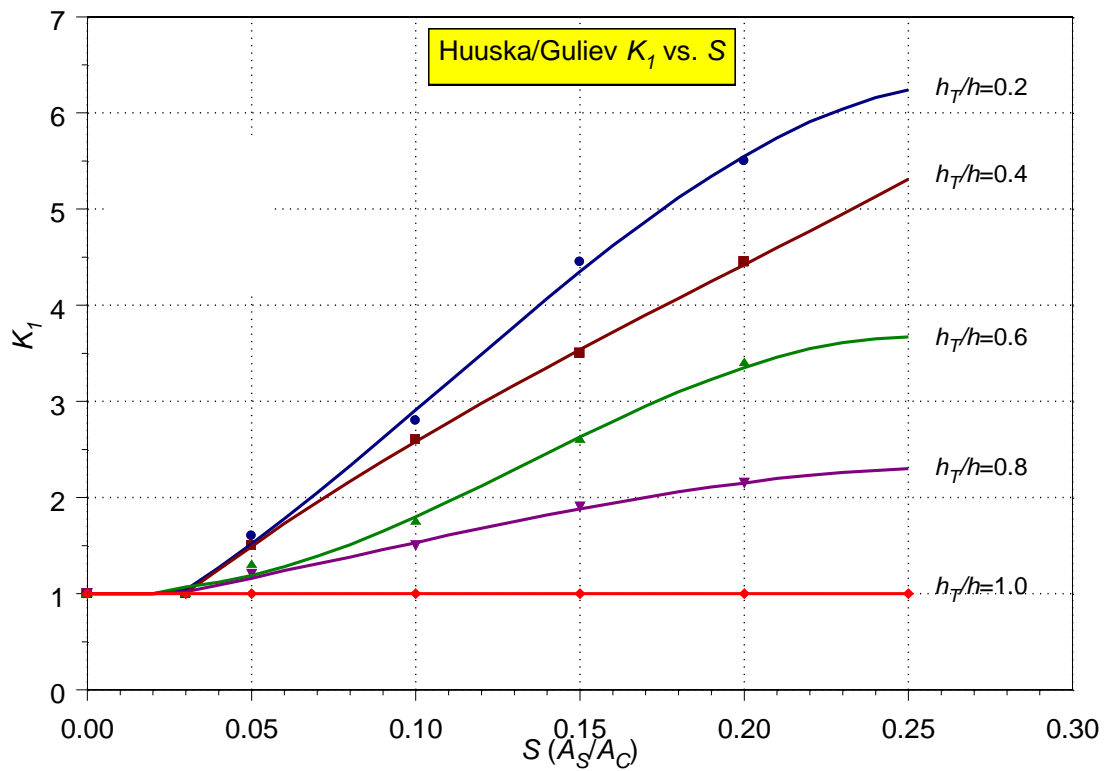

Figure D-6: Huuska/Guliev correction factor K_1 vs. S ($=A_s/A_c$) as a function of h_T/h

h_T/h	R^2	Polynomial Coefficients $K_1 = a_0 + a_1S + a_2S^2 + a_3S^3$			
		a_0	a_1	a_2	a_3
0.2	0.9985	0.46	15.85	124.06	-380.04
0.4	0.9998	0.21	28.20	-53.17	87.97
0.6	0.9961	1.10	-5.55	167.76	-417.72
0.8	0.9976	0.82	6.11	16.90	-70.86
1.0	1	1	0	0	0
Measured points from Huuska's Figure C6 (PIANC 1997)					
S	$h_T/h = 0.2$	$h_T/h = 0.4$	$h_T/h = 0.6$	$h_T/h = 0.8$	$h_T/h = 1.0$
0.00	1.00	1.00	1.00	1.00	1.00
0.03	1.00	1.00	1.00	1.00	1.00
0.05	1.60	1.50	1.30	1.20	1.00
0.10	2.80	2.60	1.75	1.50	1.00
0.15	4.45	3.50	2.60	1.90	1.00
0.20	5.50	4.45	3.40	2.15	1.00
0.25	6.25	5.30	3.65	2.30	1.00

Table D-3: Least square fit coefficients and measured points for Huuska' K_1 vs. S [Briggs 2006, 2013]

D.4.3 ICORELS (I)

The International Commission for the Reception of Large Ships (ICORELS or 'I') formula (1980) for bow squat $S_{b,I}$ (m) is similar to Hooft's and Huuska's equations. It is also based on Tuck's theory and accounts for the effect of critical speed V_{Cr} . Squat increases more than quadratic with increasing speed as a result of the use of the Tuck factor $F_{nh}^2 / \sqrt{1 - F_{nh}^2}$. It was developed for unrestricted or open channels only, so it should be used with caution if applied for restricted channels. For U channels, ICORELS is identical to Huuska's formula (see D.4.2) since $K_S = 1.0$. It is defined as:

$$S_{b,I} = C_S \frac{\nabla}{L_{pp}^2} \frac{F_{nh}^2}{\sqrt{1 - F_{nh}^2}} \quad (D-0)$$

The PIANC (1997) noted that the $C_S = 2.4$ constant is sometimes replaced with a smaller value of $C_S = 1.75$ for full form ships with larger C_B . The FMA used this formula with values of $C_S = 1.70$, 2.0, and 2.4 based on the C_B for a range of ships in unrestricted channels [FMA, 2005 ; Sirkiä, 2007].

$$C_S = \begin{cases} 1.7 & C_B < 0.70 \\ 2.0 & 0.70 \leq C_B < 0.80 \\ 2.4 & C_B \geq 0.80 \end{cases} \quad (D-0)$$

The BAW, however, recommends a value of $C_S = 2.0$ for the larger container ships which may have a $C_B < 0.70$. Their research is based on many measurements along the 100-km-long River Elbe [Uliczka and Kondziella, 2006]. Although side slope n varies from 15 to 40, much of the River Elbe can be considered as an unrestricted channel. For ships with an immersed transom stern, a larger $C_S = 3$ is recommended because of the increased bow squat due to the fact that the stern of these ships is wider than conventional ships.

Flanders Hydraulic Research (FHR) has found $C_S \geq 2.0$ for modern container ships. They typically travel at much higher speeds than the ICORELS formula was originally developed, even in shallow and restricted waters. The F_{nh} are higher and in this speed range the effect of blockage factor S on the critical ship speed is significant, as discussed in paragraph D.3.5.

D.4.4 Barrass3 (B3)

Barrass (2004) proposed the following 'short-cut' formula for maximum squat S_{Max} for all channel configurations that is relatively 'user-friendly'. Based on his work in 1979, 1981 and 2004, $S_{Max,B3}$ at the bow or stern (m) is determined by the value of the ship's C_B and V_k (knots) and the channel's dimensionless blockage factor S as:

$$S_{Max,B3} = \frac{C_B V_k^2}{100 / K} \quad (D-0)$$

where Barrass defined the dimensionless coefficient K as:

$$K = 5.74S^{0.76} \quad (D-0)$$

Finally, in 2007 Barrass proposed a modified version of his earlier version from 1979 and 1981 for predicting maximum squat S_{Max} in all channels that is based on the block coefficient C_B , ship speed V_k , and the width of influence F_B . However, it gives nearly the same values as this equation, so it is not included here.

A value of the blockage factor $S = 0.10$ is equivalent to a very wide river (unrestricted or open water conditions). The value of $K = 1$ and the denominator remains 100. For restricted channels, a value of the order of $S = 0.25$ gives a value of $K = 2$, and the denominator becomes 50. Thus, the effect of K is to modify the denominator constant between values of 50 to 100. This formula is based on over 600 laboratory and prototype measurements. Constraints on these equations are $1.10 \leq h/T \leq 1.40$ and $0.10 \leq S \leq 0.25$. This equation can accommodate a medium width river with a value of S between the limits of S above. As Barrass' formula assumes that squat is proportional to the square of the ship's speed V_k , it should always be checked to make sure that the equivalent V_s (in metric units) is sufficiently small with respect to the critical speed V_{Cr} (see previous section on V_{Cr}). The nomenclature of 'Barrass3' and 'B3' was selected since Barrass had two other formulas in use in the earlier (i.e. PIANC WG 30) reports that readers may still want to use.

As discussed earlier, Barrass claims that the value of C_B determines whether the maximum squat is at the bow or stern. For **unrestricted** channels with ships initially at even keel when at zero speed, Barrass also presented formulas for calculating squat at the other end of the ship $S_{oe,B3}$. One needs to know the squat at one end (either bow or stern), the amount of squat due to the mean body sinkage $S_{m,B3}$, and the amount due to dynamic trim $S_{t,B3}$ to apply these formulas. These values are given by:

$$\begin{aligned} S_{oe,B3} &= K_{oe} S_{Max,B3} \\ S_{m,B3} &= K_m S_{Max,B3} \\ S_{t,B3} &= K_t S_{Max,B3} \end{aligned} \quad (D-0)$$

where the coefficients are defined as:

$$\begin{aligned}
 K_{oe} &= \left[1 - 40(0.7 - C_B)^2 \right] \\
 K_m &= \left[1 - 20(0.7 - C_B)^2 \right] \\
 K_t &= 40(0.7 - C_B)^2
 \end{aligned}
 \tag{D-0}$$

Stocks et al. (2002) found that the Barrass3 formulas gave the best results for New and Traditional Lakers in the Lake St. Francis area (unrestricted channel) of the SLS study. The BAW in Hamburg, Germany, feels that the Barrass3 restricted formula is conservative for their restricted channel applications.

D.4.5 Eryuzlu2 (E2)

Eryuzlu and Hausser (1978) conducted physical model tests of large, self-propelled tankers in unrestricted channels. Each of the three VLCC models (1:100 scale) was tested at its fully-loaded draught in a large basin (76 m x 17 m x 0.35 m) at speeds between $V_k = 6$ to 15 kt. The basin width was 31 to 42 times B . The models were statically and dynamically balanced and ballasted to an even keel. The C_B coefficients varied between 0.80 and 0.85 and four to six h/T ratios were tested for each model. Very accurate measurements of squat (± 0.10 m prototype) were obtained using a laser and video camera system. They used a least squares fit of the data to a power law equation to obtain a formula for bow squat.

In 1994 Eryuzlu et al. ('Eryuzlu2' or E2) conducted some additional physical model tests and field measurements for cargo ships and bulk carriers with bulbous bows in unrestricted and restricted channels. They used self-propelled models. Many of the early PIANC formulas are based on ships without bulbous bows. The range of ship parameters was somewhat limited with $C_B \geq 0.8$, B/T from 2.4 to 2.9 and L_{pp}/B from 6.7 to 6.8. They conducted some supplemental physical model tests with an $h_T/h = 0.5$ and $n = 2$ to investigate the effect of channel width in restricted channels. In spite of these constraints, the E2 is often used for container ships with C_B less than the $C_B \geq 0.8$ criteria. Their formula for bow squat $S_{b,E2}$ (m) is defined as:

$$S_{b,E2} = 0.298 \frac{h^2}{T} \left(\frac{V_s}{\sqrt{gT}} \right)^{2.289} \left(\frac{h}{T} \right)^{-2.972} (K_b) = 0.298 T \left(\frac{h}{T} \right)^{0.1725} F_{nh}^{2.289} K_b
 \tag{D-0}$$

where h , T , V_s and g have been previously defined. Note that the left side of this equation is the original equation as presented by Eryuzlu. It is written as a function of the Ship Froude Number (i.e. V_s/\sqrt{gT}) since the ship draught T is used in the denominator instead of the channel depth h . The right side is a simplification that is somewhat easier to use. It shows a slight dependence on the depth to draught ratio h/T , and power of the speed that is slightly greater than 2. The importance of F_{nh} is included, but the formula does not account for a critical speed. Therefore, Eryuzlu's formula should always be checked to determine if the ship's speed is sufficiently small with respect to the critical speed. As the formula does not contain any ship dependent characteristics, it should not be used outside the ship parameter range mentioned in Table D-2.

The dimensionless K_b is a correction factor for channel width W relative to beam B and is given by:

$$K_b = \begin{cases} \frac{3.1}{\sqrt{W/B}} & \frac{W}{B} < 9.61 \\ 1 & \frac{W}{B} \geq 9.61 \end{cases}$$

Use the second value of $K_b = 1$ for unrestricted channels regardless of calculated effective width W_{Eff} since the channel has no boundary effects on the flow or ship.

The Canadian Coast Guard (2001) is using the Eryuzlu2 (1994) formula exclusively. Stocks et al. (2002) recommended the Eryuzlu2 formula for the Chemical Tankers in the Lake St. Louis section (unrestricted channel) of the SLS. Canadian researchers are working to improve the Eryuzlu formulas with statistical models built by regression trees (Beaulieu et al. 2009).

D.4.6 Römisch (R)

Römisch (1989) developed formulas for both bow $S_{b,R}$ and stern $S_{s,R}$ squat (m) from physical model experiments for all three channel configurations. The model ship [Römisch and Führer, 1977] was an Amanda-type with $L_{pp} = 40$ m, $B = 4.6$ m and $T = 1.75$ m. The Römisch (abbreviated 'R') empirical formulas are relatively complicated, so is usually a good candidate for the detail design phase. The range of parameters for which this formula is applicable is shown in Table D-2. The Römisch squat formulas are given by:

$$\begin{aligned} S_{b,R} &= C_V C_F K_{\Delta T} T \\ S_{s,R} &= C_V K_{\Delta T} T \end{aligned} \tag{D-0}$$

where C_V is a correction factor for ship speed, C_F is a correction factor for ship shape, and $K_{\Delta T}$ is a correction factor for squat at ship critical speed. These dimensionless coefficients are defined as:

$$C_V = 8 \left(\frac{V}{V_{Cr}} \right)^2 \left[\left(\frac{V}{V_{Cr}} - 0.5 \right)^4 + 0.0625 \right] \tag{D-0}$$

$$C_F = \left(\frac{10C_B}{L_{pp}/B} \right)^2 \tag{D-0}$$

$$K_{\Delta T} = 0.155 \sqrt{h/T} \tag{D-0}$$

Figure D-7 is a plot of Eq. D-27 for C_V and illustrates that the effect of speed on squat is more than quadratic in Römisch's method.

The value for C_F is equal to 1.0 for stern squat. If $C_F > 1$, the ship will squat by the bow. According to Eq. D-28 this occurs if $C_B > 0.1L_{pp}/B$. This can be considered as an alternative formulation for the $C_B > 0.7$ suggested by Barrass.

The ship's critical or Schijf-limiting speed V_{Cr} (m/s) is the speed that ships cannot exceed due to the energy balance between the Continuity Equation and Bernoulli's Law [USACE,

2004 ; Huval, 1980 ; Balanin et al., 1977]. For economic reasons, maximum ship speeds are typically only 80 % of V_{Cr} . The V_{Cr} varies as a function of the channel configuration given by:

$$V_{Cr} = \begin{cases} C_U K_U & \text{U} \\ C_C K_C & \text{C} \\ C_R K_R & \text{R} \end{cases} \quad (\text{D-0})$$

where the three celerity parameters C_U , C_C , and C_R (m/s) are defined as:

$$C_U = \sqrt{gh} \quad ; \quad C_C = \sqrt{gh_m} \quad ; \quad C_R = \sqrt{gh_{mT}} \quad (\text{D-0})$$

where h , h_M and h_{mT} were defined in D.2.2. Römisch's dimensionless correction factors K_U , K_C , and K_R for unrestricted, canal, and restricted channels, respectively, are defined as:

$$K_U = 0.58 \left[\left(\frac{h}{T} \right) \left(\frac{L_{pp}}{B} \right) \right]^{0.125}$$

$$K_C = \left[2 \sin \left(\frac{\arcsin(1-S)}{3} \right) \right]^{1.5} \quad (\text{D-0})$$

$$K_R = K_U (1 - h_T/h) + K_C (h_T/h)$$

Note that the definition for canal correction factor K_C is the same as previously defined for $V_{Cr}/\sqrt{gh_M}$ in Eq. D-13. Alternative formulations for K_C are published by Briggs (2006), Briggs et al. (2010) and USACE (2004). Also, note that K_R for the restricted channel is a function of both K_U and K_C .

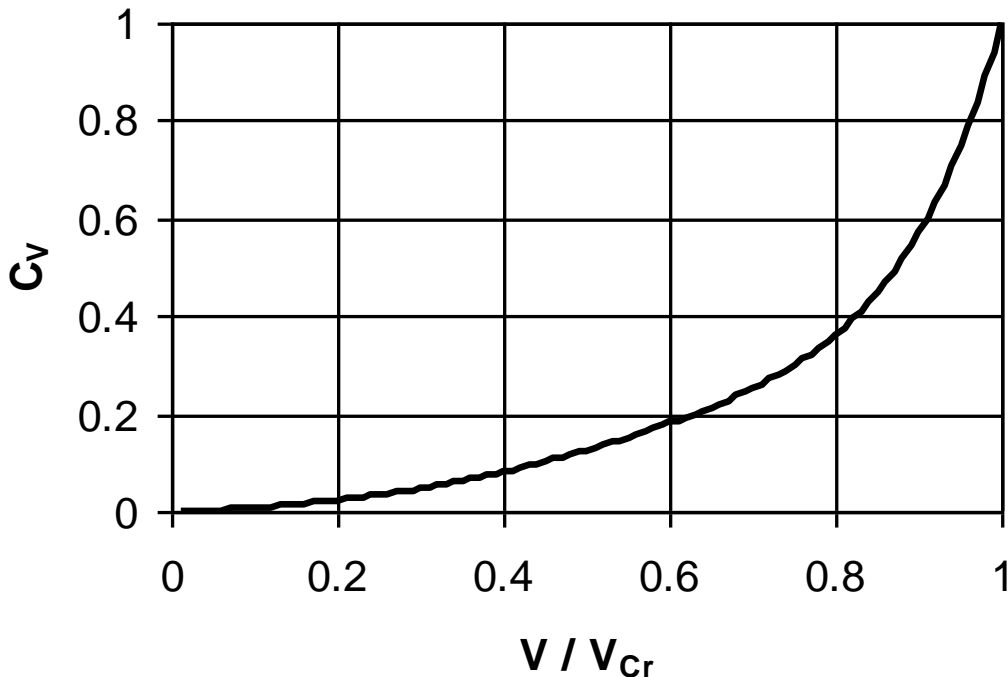

Figure D-7: Römisch's C_V as a function of V/V_{Cr}

D.4.7 Yoshimura (Y)

The Ministry of Land, Infrastructure, Transport and Tourism (MLIT 2007) proposed the following formula for bow squat as part of their new Design Standard for Fairways in Japan. The Yoshimura or 'Y' formula for bow squat $S_{b,Y}$ (m) was originally developed by Yoshimura (1986) based on experiments with a PCC and General Cargo ship for open or unrestricted channels typical of Japan. The range of parameters for which this formula is applicable is shown in Table D-2. Their equation suggests that squat is a quadratic function of ship's speed that changes as a function of the blockage factor S for 'R' and 'C' channels, but ignores the effect of a critical speed V_{Cr} . Their $S_{b,Y}$ prediction generally falls near the average for most of the other PIANC bow squat predictions, regardless of ship type, and is given by:

$$S_{b,Y} = \left[\left(0.7 + 1.5 \frac{1}{h/T} \right) \left(\frac{C_B}{L_{pp}/B} \right) + 15 \frac{1}{h/T} \left(\frac{C_B}{L_{pp}/B} \right)^3 \right] \frac{V_e^2}{g} \quad (D-0)$$

In 2007, Ohtsu and Yoshimura [Personal communication, 2007] proposed a small change to the ship equivalent velocity term V_e (m/s) to include S to improve its predictions in restricted and canal channels. It is defined as:

$$V_e = \begin{cases} V_s & U \\ \frac{V_s}{(1-S)} & R, C \end{cases} \quad (D-0)$$

D.5 Example Problems

Six example problems are presented in this section to illustrate the formulas for all three channel configurations and several ship types. Bow squat S_b is shown for all examples and stern squat S_s for some of the 'slimmer' container ships that are expected to squat by the stern. The range of UKC ranges between $1.12 \leq h/T \leq 1.35$. Comparisons of the formulas with measured values and numerical predictions are included for most of the examples.

D.5.1 BAW Model Container ship in Unrestricted Channel

The first example is based on physical model experiments at BAW for a Post-Panamax 'Mega-Jumbo' container ship travelling between $V_k = 9.0$ to 15.3 knots ($V_s = 4.6$ to 7.9 m/s) in an unrestricted channel [Hansa, 2001 ; BAW, 2005]. The 1:40 scale model was self-propelled, but loosely constrained by a taut wire running the length of the model basin. Rotating lasers were used to measure squat. Figure D-8 compares bow (D-8a) and stern (D-8b) squat from PIANC formulas and numerical model (described later in Section D.7) with the laboratory measurements. The ICORELS prediction is not shown since it is very close to the Huuska values. Dimensions of the channel and container ship are listed in Figure D-8.

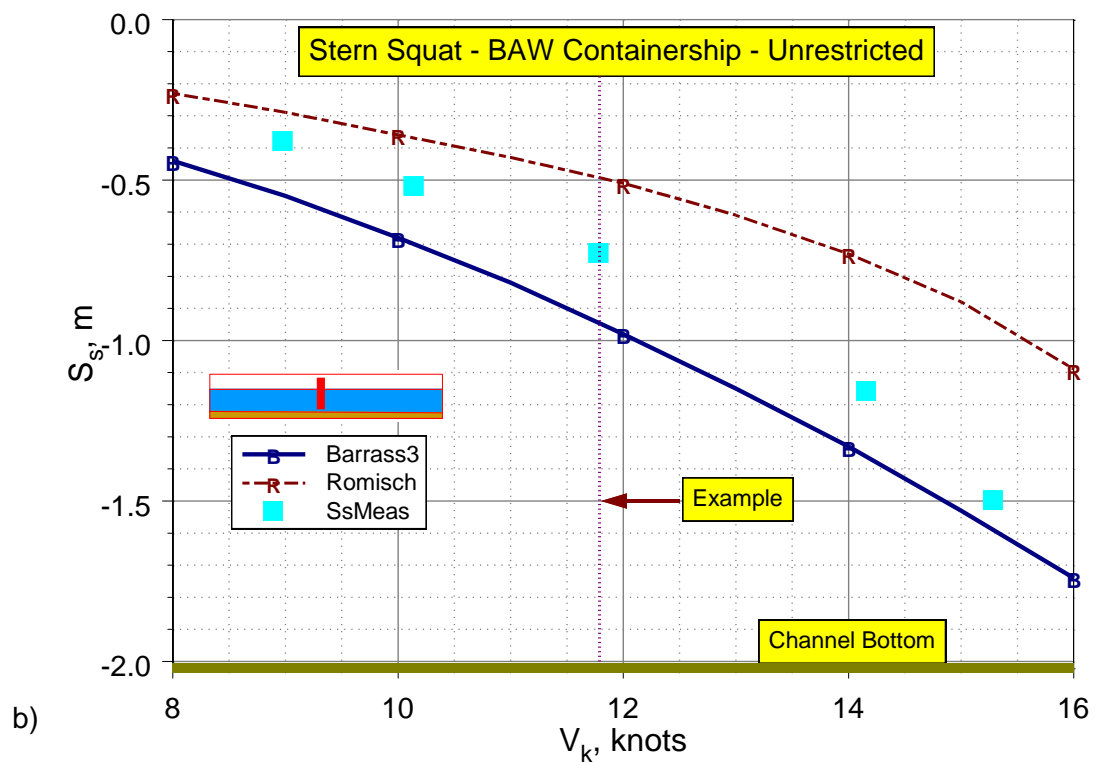
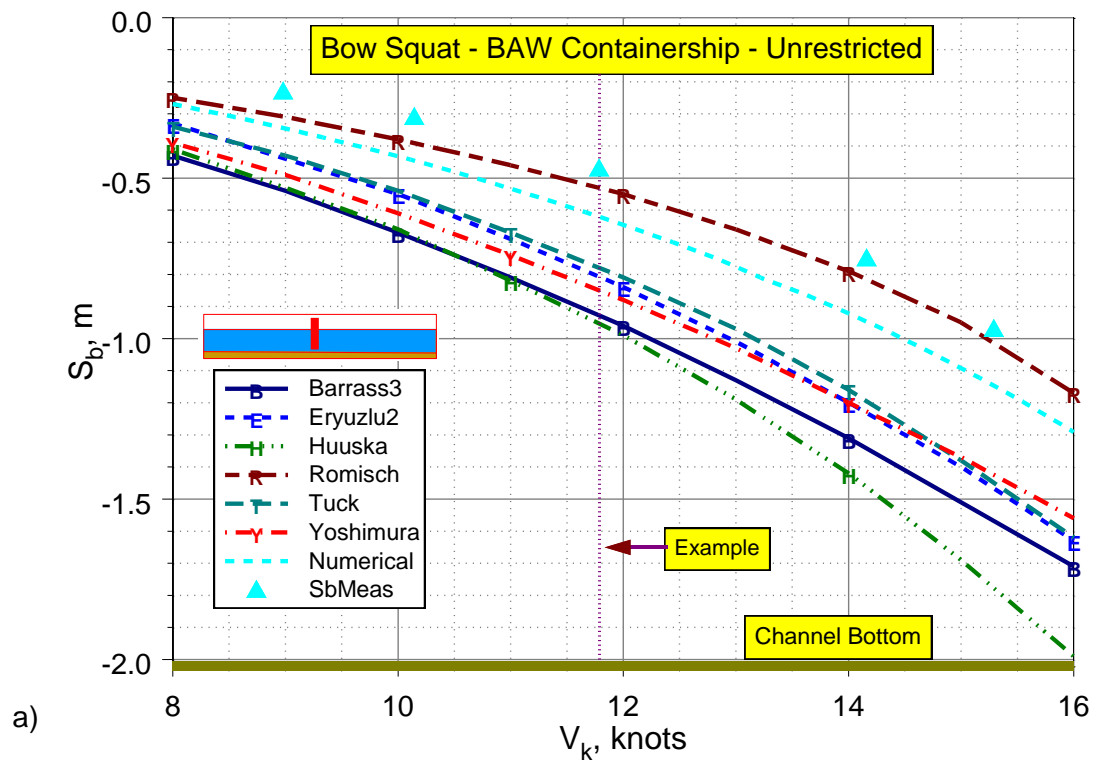

Figure D-8: (a) Bow and (b) stern squat for BAW Mega-Jumbo container ship, Unrestricted channel, $L_{pp} = 360$ m, $B = 55.0$ m, $T = 16.0$ m, $CB = 0.68$ and $h = 18.0$ m ($h/T = 1.12$)

According to Barrass, this ship should squat by the stern since its $C_B < 0.70$. As an example, the measured squat at $V_k = 11.8$ knots is $S_b = 0.47$ m at the bow (Figure D-8a) and $S_s = 0.73$ m at the stern (Figure D-8b). In general, the best PIANC formula is the Römisch for the bow squat as it is slightly larger than the measurement points. The other PIANC formulas all overpredict bow squat. The numerical model matches the measured values very well, although slightly over predicting. Only two of the PIANC formulas explicitly predict stern squat. The Barrass overpredict and the Römisch under predicts it in this example. The numerical model was not run for stern squat, so it is not shown.

This could be a good example of how the ship obviously squats by the stern, yet most of the PIANC predictions were developed for squat by the bow. If one was to use just the largest squat value regardless of bow or stern squat, then some of the other PIANC formulas would also give reasonable predictions relative to the measurements. For instance, the Tuck, Eryuzlu2, and Yoshimura formulas would give reasonable values for maximum ship squat if their bow predictions were used in comparison to the stern measurements.

Also, although $C_B = 0.68$ is only slightly smaller than Barrass's $C_B = 0.7$, the dynamic trim is quite important in this example. Neither Barrass nor Römisch are able to predict the trim. The user should always be aware of the constraints and limitations of the different theories. Although all of the results are plotted, some violated the constraints listed in Table D-2. For the input parameters and velocity range in this example; values of $C_B = 0.68$, $h/T = 1.12$ (smallest UKC example), $L_{pp}/T = 22.50$, $B/T = 3.44$ and $L_{pp}/B = 6.55$ exceeded the stated constraints for some of the formulas. These constraint violations may not be significant, but the user should be aware of them and use *engineering judgment* in deciding which of the estimates to use.

D.5.2 SR108 Container Ship in Unrestricted Channel

The second example is for an SR108 container ship travelling between $V_k = 4.0$ to 16.0 knots ($V_s = 2.10$ to 8.2 m/s) in an unrestricted channel. Figure D-9 shows bow squat comparisons among the various PIANC formulas and the numerical model predictions. The dimensions of the ship and channel are shown in Figure D-9. A $C_B = 0.66$ value was calculated for this model based on dimensions. Again, ICORELS prediction is not shown since it is nearly identical to those of Huuska. Although not shown, Barrass and Römisch stern squat are 8 to 9 % larger, respectively, than bow squat values shown in Figure D-9. As before, these larger stern squat values are to be expected according to Barrass's criterion for C_B .

Although there are no measured data for this example, we can use the numerical model as a guide. In this case, the best formulas would be the Yoshimura, Tuck and Römisch. All overpredict except for Römisch which under predicts squat until $V_k > 14$ knots.

As before, although all of the results are plotted, some violated the constraints listed in Table D-2. For the input parameters and velocity range in this example; values of $0.19 \leq F_{nh} \leq 0.78$, $C_B = 0.66$, $L_{pp}/h = 15.35$ and $L_{pp}/B = 6.89$ exceeded the stated constraints for some of the formulas. These constraint violations may not be significant, but the user should be aware of them and use *engineering judgment* in deciding which of the estimates to use.

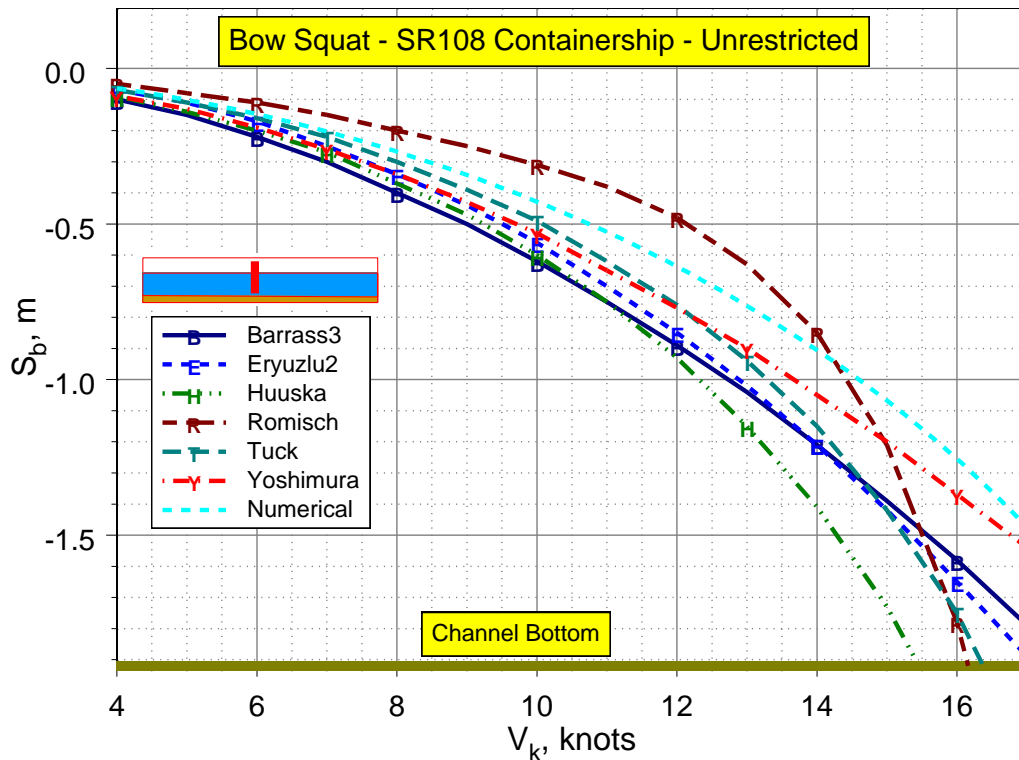

Figure D-9: Bow squat for SR108 Container ship, Unrestricted channel, $L_{pp} = 175$ m, $B = 25.4$ m, $T = 9.5$ m, $CB = 0.66$ and $h = 11.4$ m ($h/T = 1.20$)

D.5.3 FHR Model Container Ship in Restricted Channel

The next example is for the FHR 92 and FHR 265 container ships travelling between $V_k = 8.0$ to 14.0 knots ($V_s = 4.1$ to 7.2 m/s) in their laboratory tow-carriage. The data are from the FHR 1:80.8 scale model to study bank effects for different relative distances of the ship from the channel sides [Vantorre and Dumon, 2004]. Because the side walls were made to simulate a restricted channel on one side (the other side is the vertical flume walls), a restricted channel is the most appropriate channel type for this example (Figure D-10a).

Figure D-10b shows comparisons among the various PIANC formulas and the measured laboratory values. Dimensions of the ship and channel are listed in Figure D-10. For FHR 92, the measured squat at the bow $S_b = 0.83$ m at $V_k = 14$ knots. This experiment is very interesting because it examines bank effects that have not been taken into account in the existing empirical formulas. Since this is an area of active research, additional discussion is provided in section D.6.2. For the FHR 92 ship, the Yoshimura predictions are better for $V_k \geq 14$ knots. The Römisch predictions are better for the slower speeds (although slightly underestimated). The FHR 265 container ship, which was closer to the right or restricted channel side than the FHR 92, is also shown. The Huuska is the best fit for this condition, although all of the formulas are reasonable except for Römisch. The numerical model does a good job of prediction for both the FHR 92 and FHR 265.

Although all of the results are plotted, some violated the constraints listed in Table D-2. Note that $h/T = 1.35$ is the largest UKC of the example problems. For the input parameters and velocity range in this example; values of $0.31 \leq F_{rh} \leq 0.36$, $C_B = 0.65$, $L_{pp}/h = 16.88$, $L_{pp}/B = 7.74$ and $B/T = 2.94$ exceeded the stated constraints for some of

the formulas. Again, be sure to use *engineering judgment* in deciding which of the estimates to use.

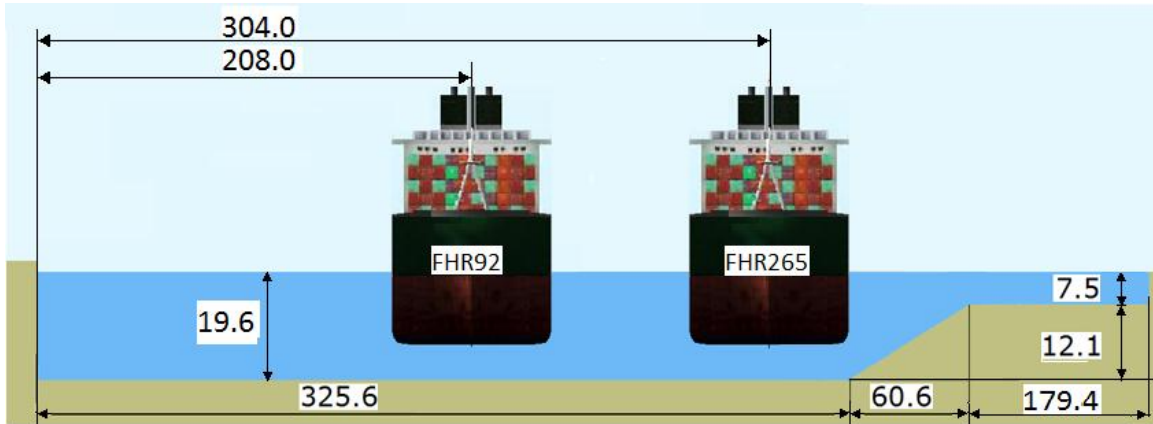

a)

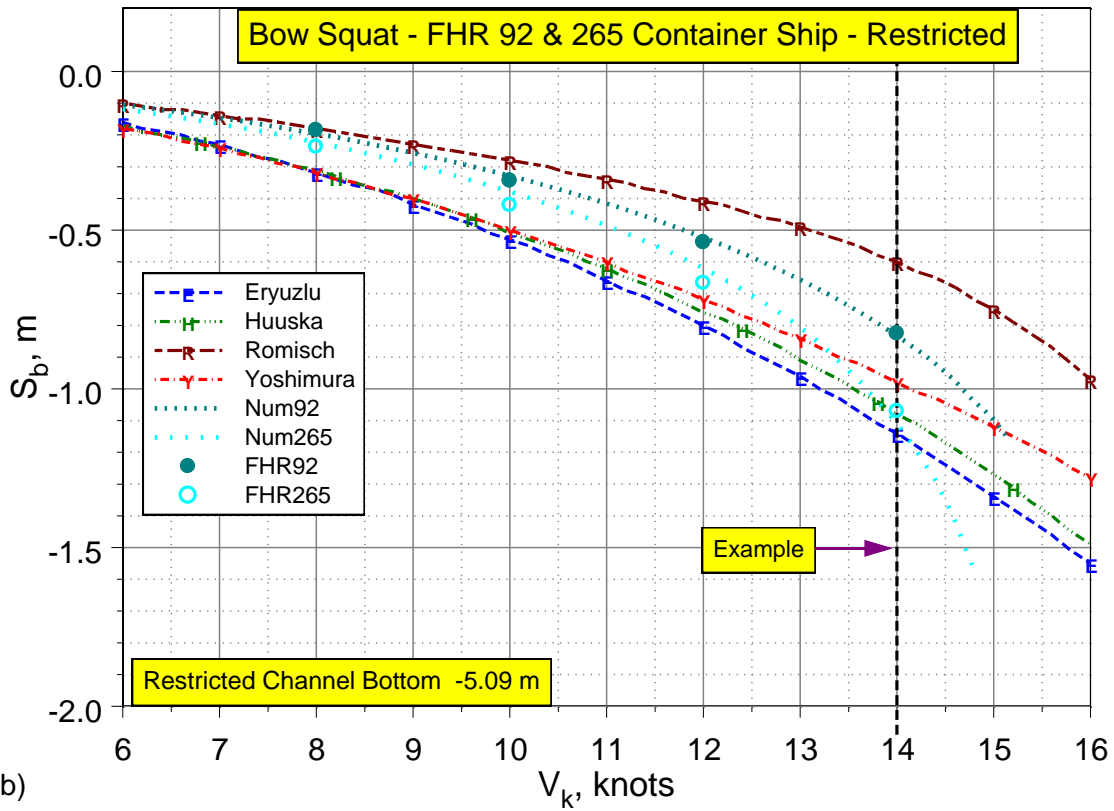

b)

Figure D-10: (a) Restricted channel cross-section, (b) bow squat for FHR 92 and FHR 265 Container ships, $L_{pp} = 331.28$ m, $B = 42.82$ m, $T = 14.54$ m, $C_B = 0.65$, $h = 19.63$ m ($h/T = 1.35$), $h_T = 12.12$ m, $W = 325.62$ m, $W_{Top} = 521.92$ m and $n = 5.0$

D.5.4 BAW Model Container Ship in Restricted Channel

This fourth example is for the same BAW ‘Mega-Jumbo’ model container ship that was used as an unrestricted channel example. Ship speed ranged from $V_k = 8.6$ to 15.2 knots ($V_s = 4.4$ to 7.8 m/s) in a restricted channel configuration [Hansa, 2001 ; BAW, 2005]. Figure D-11 compares PIANC squat predictions to the laboratory measurements and numerical predictions. Dimensions of the restricted channel and container ship are listed in Figure D-11. The model channel had slightly steeper side slopes with $n = 4$ than the previous restricted channel example, but the channel was symmetrical.

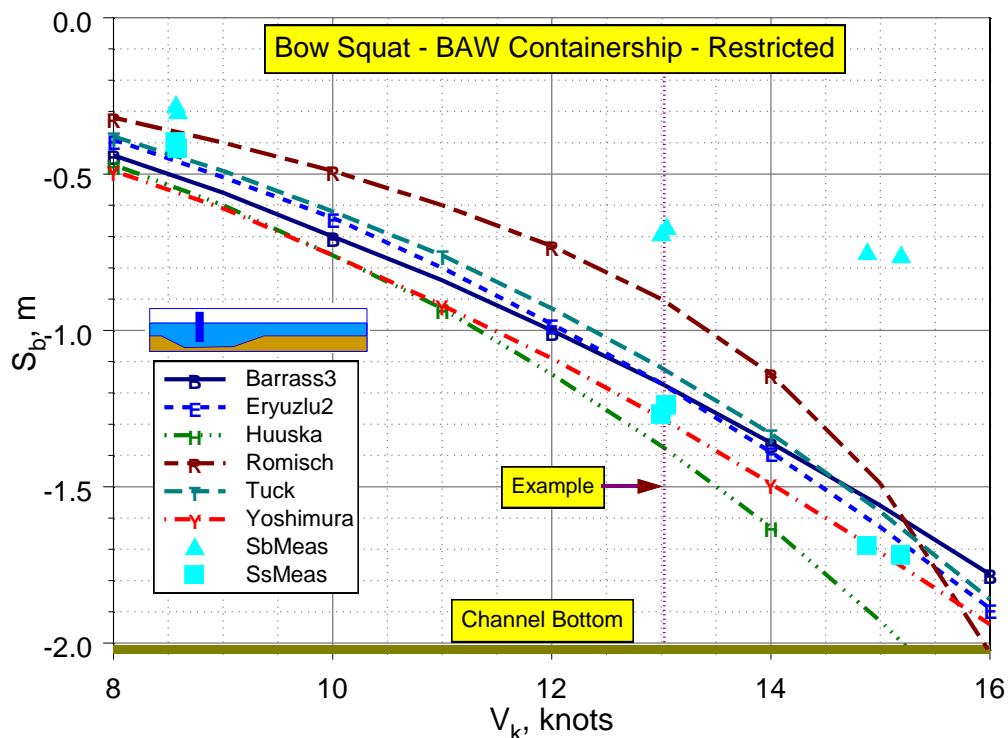

Figure D-11: Bow squat for BAW ‘Mega-Jumbo’ Container ship, Restricted channel, $L_{pp} = 360.0$ m, $B = 55.0$ m, $T = 16.0$ m, $C_B = 0.68$, $h = 18.0$ m ($h/T = 1.12$), $h_T = 9.0$ m, $W = 392.0$ m, $W_{Top} = 536.0$ m and $n = 4.0$

As an example, the measured bow and stern squat $S_b = 0.69$ m and $S_s = 1.27$ m at $V_k = 13$ knots. All PIANC predictions in Figure D-11 are for bow squat except for Barrass. According to his criterion for C_B , the ship should squat at the stern, so he reports his values at the stern. Since the $C_B = 0.68$ is very close to the Barrass threshold of $C_B = 0.70$, one might expect that bow and stern squat are nearly identical. Therefore, the bow squat predictions are shown in this example although the stern squat predictions might be larger. However, since the Römisch stern squat (not shown) is surprisingly 7 % smaller than the bow squat, this may be a reasonable assumption. The numerical stern squat predictions slightly under predict the measured stern squat. It is interesting that all of the PIANC bow predictions are more in agreement with the measured stern squat rather than the bow squat. Also, the measured bow squat values seem to level off after $V_k = 13$ knots, an indication that the bow is experiencing some complicated hydrodynamics, possibly even planing. It demonstrates that there is room for improvement in some of the complicated ship geometries one encounters in deep draught channel design.

Again, although all of the results are plotted, some violated the constraints listed in Table D-2. For the input parameters and velocity range in this example; values of $C_B = 0.68$, $h/T = 1.12$ (again, smallest UKC used in example problems), $L_{pp}/T = 22.5$, $B/T = 3.44$ and $L_{pp}/B = 6.55$ exceeded the stated constraints for some of the formulas. Again, be sure to use *engineering judgment* in deciding which of the estimates to use.

D.5.5 Esso France Model Tanker in Suez Canal

The next example is for the tanker *Esso France* travelling between $V_k = 6.7$ to 7.8 knots ($V_s = 3.5$ to 4.0 m/s) in the Suez Canal. Although the side walls of the canal do not extend out of the water (Figure D-12a), this was considered a canal channel application since the ratio of $h_T/h = 0.85$ tends to 1.0 for an 'idealised' canal cross-section. Since this is actually the Suez Canal, this is an appropriate assumption. The data are from Suquet's 1/25 scale model (1958).

Figure D-12b shows comparisons among the various PIANC formulas, measured laboratory values, and numerical model predictions. The dimensions of the ship and channel are listed in Figure D-12. As an example, the measured squat at the bow $S_b = 0.80$ m at $V_k = 7.43$ knots. In general, the best formulas are Barrass3 and Huuska as they match measurement points reasonably well. Both overpredict squat up to the example speed of $V_k = 7.43$ knots, then they both under predict squat. The Römisch squat predictions slightly overpredicted for all ship speeds in this example, although they followed the trend of the data. The Römisch predictions for a restricted 'RR' channel are also shown on this figure since they illustrate how the different channel types affect the predictions. In this case, Römisch are much better if the channel is modelled as a restricted channel using the actual trench height ratio $h_T/h = 0.85$. Again, the numerical model matches the measured values very well.

Although all of the results are plotted, some violated the constraints listed in Table D-2. Note that $h/T = 1.24$ for this example. For the input parameters and velocity range in this example; values of $0.31 \leq F_{nh} \leq 0.36$, $C_B = 0.80$, $L_{pp}/h = 15.97$, $L_{pp}/B = 7.44$ and $h_T/h = 1.00$ (for canal) exceeded the stated constraints for some of the formulas. Therefore, although these constraint violations may be insignificant, be sure to use *engineering judgment* in deciding which of the estimates to use.

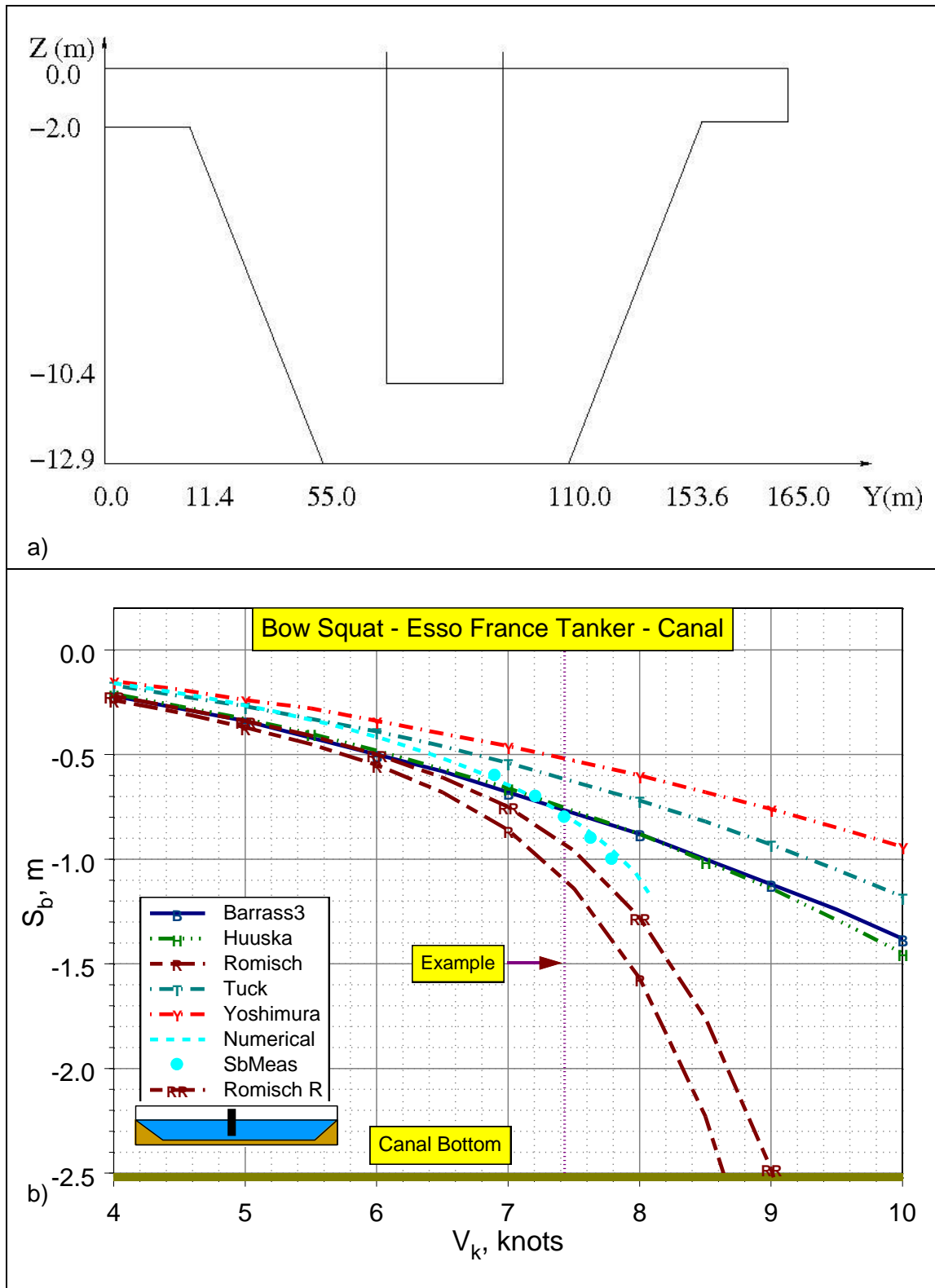

Figure D-12: (a) Suez Canal model cross-section, (b) bow squat for Esso France Tanker, $L_{pp} = 206$ m, $B = 27.7$ m, $T = 10.4$ m, $C_B = 0.80$, $h = 12.9$ m ($h/T = 1.24$), $h_T = 10.9$ m (85 % water depth), $W = 55$ m, $W_{Top} = 158.2$ m and $n = 4.0$

D.5.6 Global Challenger Bulk Carrier in Panama Canal

The last example is for the bulk carrier *Global Challenger* travelling between $V_k = 9.2$ to 9.5 knots ($V_s = 4.7$ to 4.9 m/s) in the Panama Canal. In December 1997, field measurements of bow and stern squat [Daggett and Hewlett, 1998a and 1998b ; Ankudinov et al., 2000] were made in the Gaillard Cut section using a Differential Global Positioning System (DGPS). The Gaillard Cut has a typical ‘canal’ cross-section with a width of 152 m. The DGPS was mounted at three points on the ship and had vertical accuracy levels of 1 cm. Samples were collected with a frequency of 1 Hz.

Figure D-13 shows bow squat comparisons among the various PIANC formulas, numerical model, and the field measurements. Ship and channel dimensions are listed on Figure D-13. As an example, measured bow squat are shown for 100 measurements covering approximately 1.5 km from mile marker 53.8 to 55.3 km in the Gaillard Cut. The speed range was reasonably constant in this section, varying from $V_k = 9.2$ to 9.5 knots. Corresponding bow squat varied from $S_b = 1.15$ to 1.38 m. In general, the best formulas are the Huuska and Römisch, although they both slightly under predict the measured data. The Barrass3, Tuck, and Yoshimura underpredicted measured bow squat. The numerical model slightly under predicts, with trends similar to Römisch.

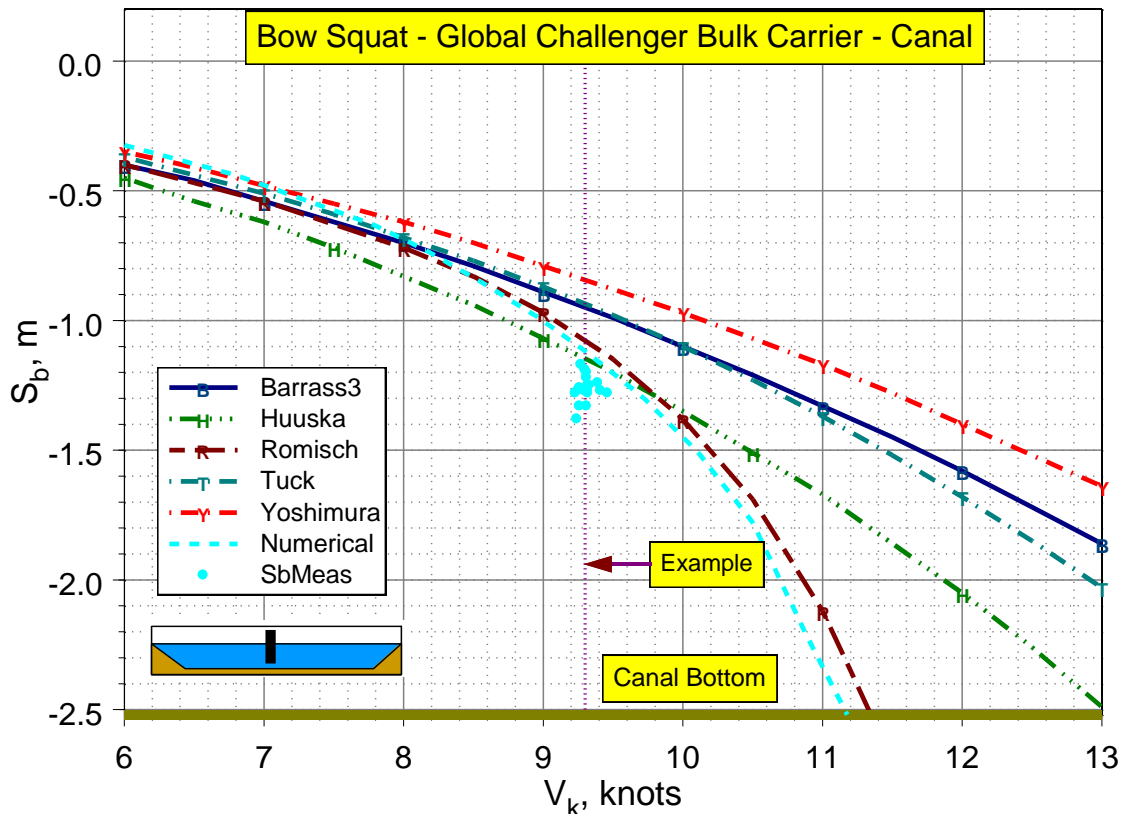

Figure D-13: Bow squat for *Global Challenger* Bulk Carrier, Panama Canal, $L_{pp} = 216$ m, $B = 32.2$ m, $T = 11.7$ m, $C_B = 0.83$, $h = 14.2$ m ($h/T = 1.21$), $W = 152.4$ m, $W_{Top} = 206.4$ m and $n = 1.9$

Again, although all of the results are plotted, some violated the constraints listed in Table D-2. For the input parameters and velocity range in this example; values of $C_B = 0.83$, $L_{pp}/h = 15.21$ and $h_T/h = 1.00$ (for canal) exceeded the stated constraints for some of the

formulas. Therefore, although these constraint violations may be insignificant, be sure to use engineering judgment in deciding which of the estimates to use.

D.6. Special Effects on Squat

The IANAC empirical formulas for predicting ship squat are based on 'idealised' conditions with single vessels that are sailing along the centreline of symmetric channels. Real world channels and ship transits are seldom this simple. This section discusses some active research in laboratory and field measurements of ship head-on passing encounters and overtaking manoeuvres in two-way traffic, proximity of channel banks (offset and drift angle effects for ships sailing off the centreline with drift angles), channel bottom configurations, muddy bottom effects and stern-transom effects.

The sections D.6.1 to D.6.3 deal with special investigations which result in higher squat values (compared with the empirical IANAC squat formulas discussed so far). The channel designer needs to perform a thorough assessment to determine whether additional channel depth is required since additional channel depth involves higher costs for dredging and maintenance. This additional cost might be justified if the design ship is in a long two-way channel with tidal windows that will require meeting and passing other deep-draught ships. The assessment of the cost/benefit should consider the availability of VTS, favourable water and weather conditions, speed reductions, restrictions on passing and overtaking, etc.

D.6.1 Passing and Overtaking Ships

When two ships pass or overtake each other, the water flow and corresponding squat is affected as a function of the other ship's size, speed and direction of travel, hull-to-hull distance between ships and the channels configuration. Dand (1981) was one of the first to study this phenomenon. He found increases in bow squat of 50 to 100 % during passing and overtaking encounters. Although these increases are relatively large, they are consistent with current research on passing and overtaking ships. Finally, it should be remembered that one of the most important parameters affecting squat due to ship-to-ship interaction is speed through the water.

D.6.1.1 Head-On Passing Encounters

During the past 10 years, the BAW has conducted many field and laboratory studies of head-on passing encounters and overtaking manoeuvres of ships in restricted channels. Preliminary studies of the dynamic response of large container ships in laboratory models have shown tendencies of reduced squat [Uliczka and Flügge, 2001 ; Flügge and Uliczka, 2001a and b]. Recently, laboratory experiments of head-on passing encounters between a Panamax (PM) container ship (PM32) and a Post-Panamax (PPM) bulk carrier (MG58) were investigated. An additional increase in maximum bow squat $\Delta S \approx 0.6$ m for the PM32 ($V_k = 14$ knots) was recorded due to the passing encounter with the MG58 ($V_k = 12$ knots). The trim of the PM32 changed from even keel for single runs in the channel and low speeds to bow trim at higher passing speeds. The larger and slower MG58 experienced additional squat of $\Delta S \approx 0.2$ m at the stern. The trim of the MG58 changed only slightly at the stern from its original trim as a single ship in the channel.

The BAW conducted field measurements of 12 transits on PPM container ships along the River Elbe between April 2003 and June 2004. During the 7-hour transits of the 12 ships from Hamburg to the sea, 125 head-on passing encounters were recorded. The increase in squat was about the same at both the bow and stern. For this set of large container

ships in the River Elbe, the maximum increase in squat was $\Delta S \approx 0.44$ m. 50 % of the cases experienced bow or stern squat less than $\Delta S \approx 0.16$ m, while 90 % were less than $\Delta S \approx 0.33$ m. Additional details for both laboratory and field examples are contained in Briggs et al. (2010).

The FHR (in co-operation with Ghent University) has conducted laboratory experiments to study passing and overtaking in their automated towing tank to improve their ship simulator [Vantorre et al., 2002b]. They studied head-on passing encounters between a container ship ($L_{oa} = 291.3$ m, $B = 40.3$ m, $T = 13.5$ m) sailing at a forward speed of 12 knots and a bulk carrier ($L_{oa} = 310.6$ m, $B = 37.8$ m, $T = 13.5$ m). The lateral distance between the two centrelines was 114.5 m and the water depth was 17.1 m. When the two bows meet, the ship's bow sinkage increases, while the stern is lifted, resulting in trim by the bow. The trim changes sign when the midships sections of both ships are at the same position. During the second part of the meeting, the sinkage aft is increased while the bow is lifted. The sinkage aft of the container ship increases from an initial value of $\Delta S \approx 0.6$ m to about 0.9 m if the bulk carrier has a speed of 8 knots and to about $\Delta S \approx 1.2$ m when both ships have a speed of 12 knots. This corresponds to an increase in squat of 50 % for the 8 knot case and 100 % for the 12 knot case.

D.6.1.2 Overtaking Manoeuvres

The BAW studied squat interactions between overtaking Feeder (VG3) and General Cargo (VG4) vessels (travelling in the same direction) in a 1:33.3 scale laboratory model of the western Kiel Canal. The lateral passing distance during the time when the ships were parallel was 54 m (between course lines). Maximum overtaking squat values were measured only during the time when both ships were aligned parallel to each other. Overtaking manoeuvres increase squat due to the effect of the additional hydrodynamic mass and channel blockage of each ship. The increase in stern squat for the VG3 was $\Delta S \approx 0.6$ m and $\Delta S \approx 0.8$ m for the VG4 at a speed of $V_k = 8.1$ knots. Since both ships experienced a common speed-dependent long wave, they had the same order of magnitude of total stern squat $S_s = 1.0$ m at $V_k = 8.1$ knots. The shorter VG3 squatted with even keel in the long wave of the larger VG4.

The FHR also conducted laboratory experiments on overtaking manoeuvres for the same container ship from the ship passing experiments, sailing at a speed of 12 knots, while overtaking a bulk carrier ($L_{oa} = 301.5$ m, $B = 46.7$ m, $T = 15.5$ m) sailing at 8 knots. The water depth was 18.6 m. Three lateral distances between centrelines from 84 m to 205 m were investigated. Squat increased up to $\Delta S \approx 0.3$ m as the lateral distance decreased between vessels during these overtaking experiments. This is equivalent to an increase in squat of over 40 %.

D.6.2 Proximity of Channel Banks

Ships in the PIANC formulas are idealised by assuming that they are sailing on the centreline of the channel. When ships are offset from the centreline, they experience increased squat because the hydrodynamic pressure is affected by the bank. The National Ports Council (1980) showed that squat increases as the UKC and distance D between the ship's centreline and the toe of the bank decrease relative to beam B . Squat increased in a restricted channel from 16 to 47 % for $1.1 \leq h/T \leq 1.2$, $0.5B \leq D \leq B$ and C_B from 0.70 to 0.85. Squat increased even more in a canal due to the larger bank effect. The bank effect became insignificant for $D > 3B$.

Similarly, a ship with a drift angle to the channel centreline experiences increased water flow past the hull due to the increased blockage factor and a smaller gap between the ship and the channel bank. The ship acts as a lifting surface as it moves asymmetrically through the water. Drift angles are usually the result of trying to compensate for large wind forces, especially on container ships, ferries and cruise ships.

The Delft University of Technology (Delft) recently completed a limited set of numerical models of ship squat for ships sailing with an offset and drift angle to the channel centreline [de Koning Gans and Boonstra, 2007]. A panel method was used in the tests for a PPM container ship with one draught but a range of offsets (0 and ± 20 m) and drift angles (0, ± 7.5 deg and ± 15 deg). For the modelled ship ($L_{pp} = 302$ m, $B = 42.9$ m, $T = 14$ m and $C_B = 0.67$) and channel ($W = 300$ m and $h = 16$ m), the UKC was 2 m. They found that both offsets and drift angles increase squat, in a quadratic manner. High drift angles should be avoided by using tugs if available. They recommended additional research for a range of ships, channels, UKC, offsets and drift angles.

The FHR has conducted towing tank experiments with container ships to study ship offset and drift angle effects on squat. They found that moving the ship laterally from the centre of the channel to the toe of the bank results in an increase in squat of about 20 %. This effect is amplified considerably at higher ship speeds, however. A slight bow squat turns into a significant stern squat and it is clear that the ship sailing off-centre will reach its critical speed much sooner. The bow sinkage increases significantly as drift angle increases, while the stern sinkage decreases slightly.

D.6.3 Channel Bottom Configurations

The PIANC formulas are for idealised channel bottoms that are relatively flat (i.e. horizontal). Real-world channels, however, are seldom this way especially where the navigation channel meets the offshore contours or enters more sheltered waters. They may have abrupt changes in channel bathymetry, sills, ripples, unsymmetrical channel cross sections, etc. An abrupt change in depth or sill due to dredging can induce a significant transient squat that can be critical if the ship is entering at deep water speeds. Generally, if the ship is close enough to the bottom that it can 'feel' the bottom, ship squat will increase if the depth decreases. Some channels are characterised by undulating ripples along the channel bottom that can have significant vertical rise above the bottom. There has been little new research on these effects, but the designer should be aware of their potential impact. The BAW has conducted some laboratory experiments on the effects of these ripples on ship squat, but additional research is recommended. Of course, the ripples do not pose a hazard necessarily relative to channel depth as they would not damage a ship due to touching, just that they will potentially affect the ship's squat.

D.6.4 Muddy Bottoms

The presence of a fluid mud layer on the bottom of a channel influences the sinkage and trim of a vessel due to speed and underkeel clearance considerations. The interested reader should also see Appendix E.

- The pressure field around the moving hull causes undulations of the water-mud interface ('internal waves') which, in turn, modify the distribution of vertical forces over the length of the ship and, therefore, sinkage and trim. As the interface deformation is a function of ship speed, these effects are speed-dependent

- If the ship's keel penetrates the mud layer, the hydrostatic (buoyancy) force acting on the submerged part of the ship is increased due to the higher density of the mud. This effect is UKC-dependent.

The effect of the presence of a fluid mud layer covering the bottom on the ship's vertical motions is closely related to the interface deformation. If no contact between the ship's keel and the mud layer occurs (Figures D-14a and D-14c), a rising interface yields an increased velocity of the ship relative to the water and, as a result, a pressure drop and a local water depression. A mud-water interface sinkage, on the other hand, leads to a local decrease of the relative velocity and an increased pressure, at least compared to the solid bottom case. In case of contact between keel and a rising mud interface (Figure D-14b), the velocity of the mud relative to the ship's surface decreases. Contact with a lowered interface with negative UKC (Figure D-14d) leads to an increased relative fluid velocity, with associated local pressure fluctuations acting on the ship's keel.

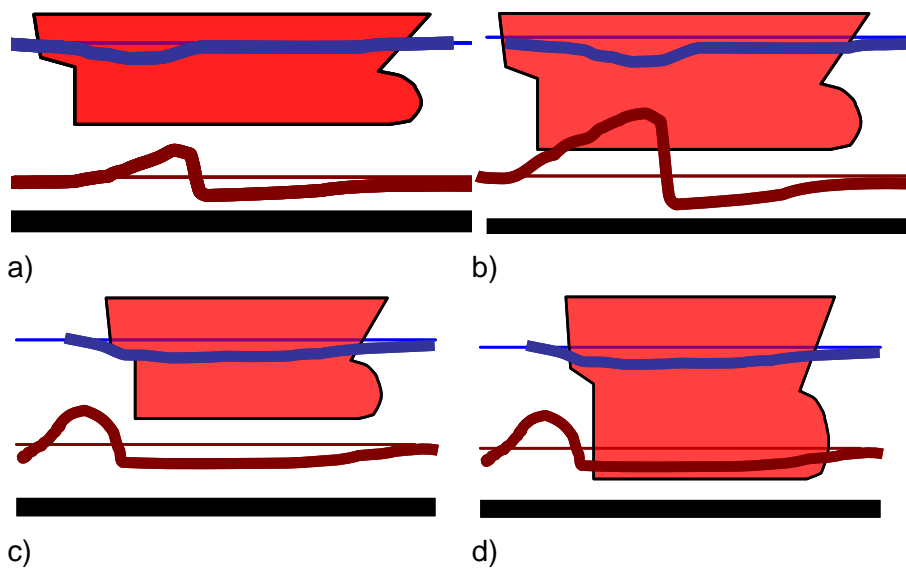

Figure D-14: Effect of mud layers on sinkage and trim (a) no interface contact, (b) contact with mud interface, (c) no contact with interface and (d) negative UKC. The blue line represents water surface, brown line mud layer interface, and black the solid bottom
[van Craenenbroeck et al., 1991]

Figure D-15 illustrates the effect of the presence of a mud layer on the sinkage and trim of a container ship for the case in which the initial UKC is sufficiently large so that the interface undulations do not cause any contact between the keel and the mud layer. The sinkage for a ship sailing in a muddy bottom condition is decreased relative to the condition in which the mud layer is replaced by a solid bottom. This is because the ship can 'feel' the hard bottom more than the softer, less dense, mud layer. If the mud layer is replaced by water (normal conditions without a mud layer), however, the sinkage would decrease relative to the condition with the mud layer. However, this does not take into account the effect of extra buoyancy (i.e. mud is denser than water), but this is only important in very dense mud layers and/or significant penetration. In general, the influence on trim is more important than sinkage since the mud layer causes the ship to be dynamically trimmed by the stern over its complete speed range. Thus, the effect of mud layers on average sinkage is only marginal as trim is much more important. The effect of the decrease of UKC is shown in Figure D-16. In a range of small positive to negative UKC, the trim is mostly affected in a moderate speed range (second speed range, as defined above). A large negative UKC (keel into the bottom mud-water

interface) causes trim by the stern in the complete speed range. The effect of mud on the average sinkage is less important, but the combination of trim and sinkage results in an increase of the sinkage aft in some conditions.

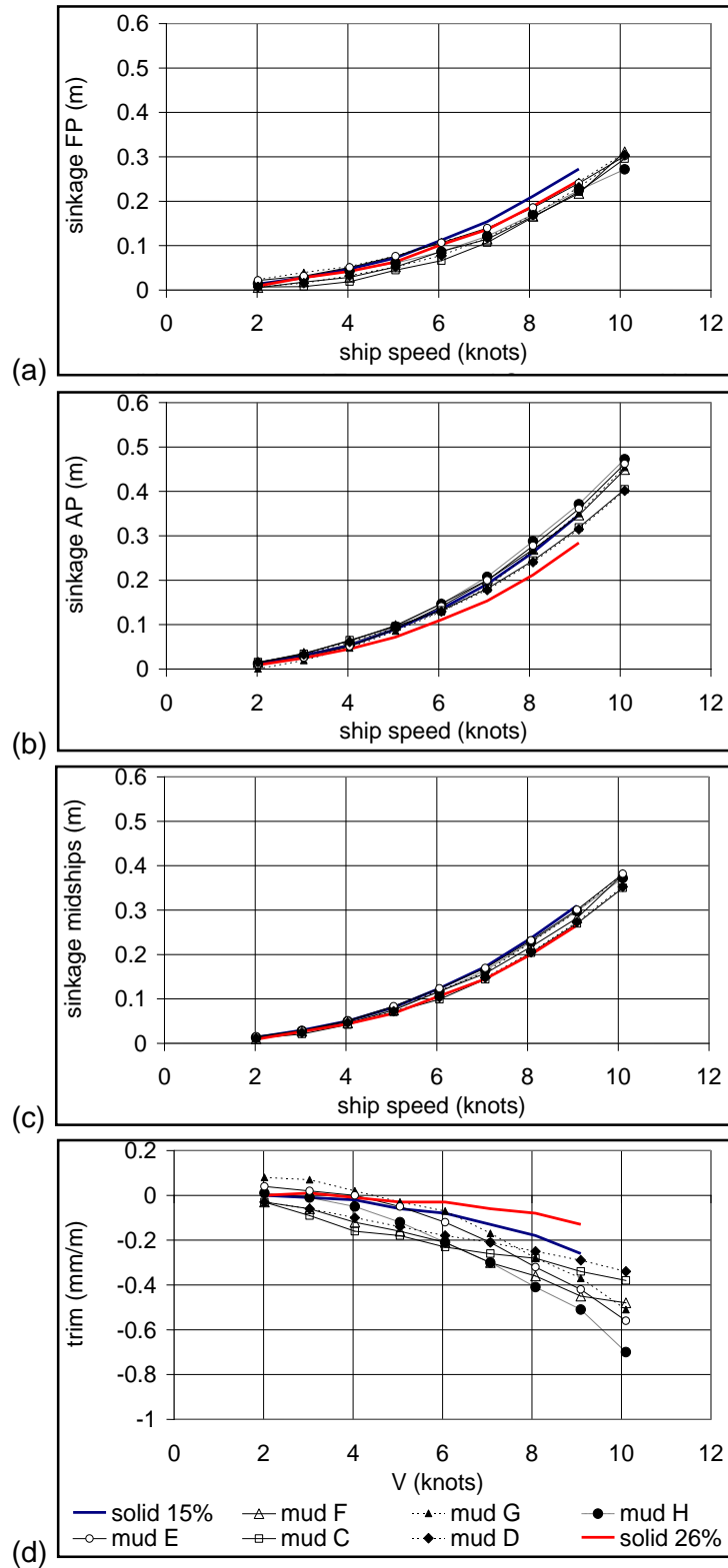

Figure D-15: Sinkage (a) fore, (b) aft, (c) midships and (d) trim as a function of ship speed for Container ship D sailing above a mud layer of 1.5 m thickness with 15 % clearance referenced to mud-water interface (26 % to solid bottom). Note the legends are the same for all plots ($L_{oa} = 300$ m, $B = 40.3$ m, $h = 13.5$ m) [Delefortrie, 2007]

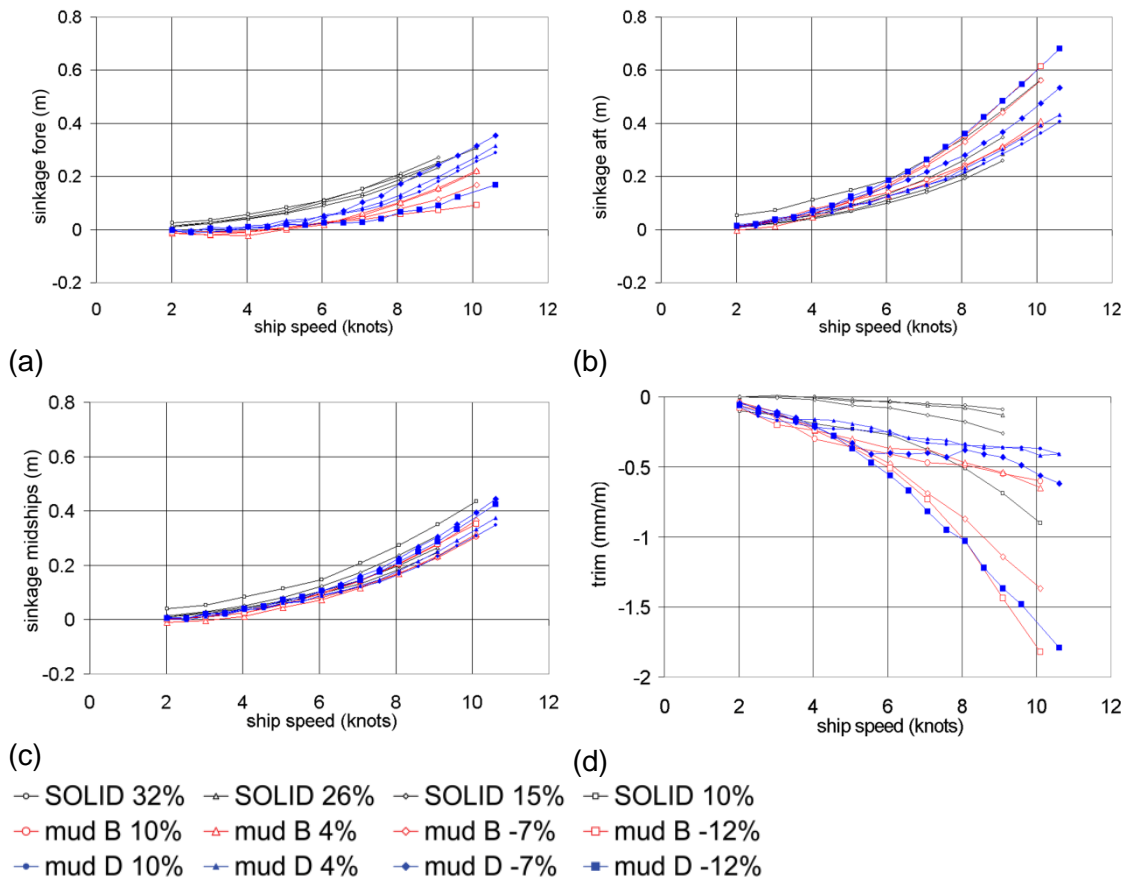

Figure D-16: Sinkage (a) fore, (b) aft, (c) midships and (d) trim as a function of ship speed for Container ship D sailing above a mud layer of 3.0 m thickness, ($L_{oa} = 300$ m, $B = 40.3$ m, $h = 13.5$ m), $\rho_B = 1,180$ kg/m³, $\rho_D = 1,100$ kg/m³ [Delefortrie, 2007]

Figures D-15 and D-16 are valid for slender ships ($C_B < 0.7$) that tend to trim by the stern above a solid bottom. Full-formed ships, on the other hand, usually trim by the bow. In muddy navigation areas, such vessels will experience a reduced trim by the bow – or even trim by the stern – when they have sufficient UKC in the second speed range. In the third speed range, this effect will be reduced again. Figure D-17 shows this effect of midships sinkage and trim as a function of UKC for a full-form trailing suction hopper dredge.

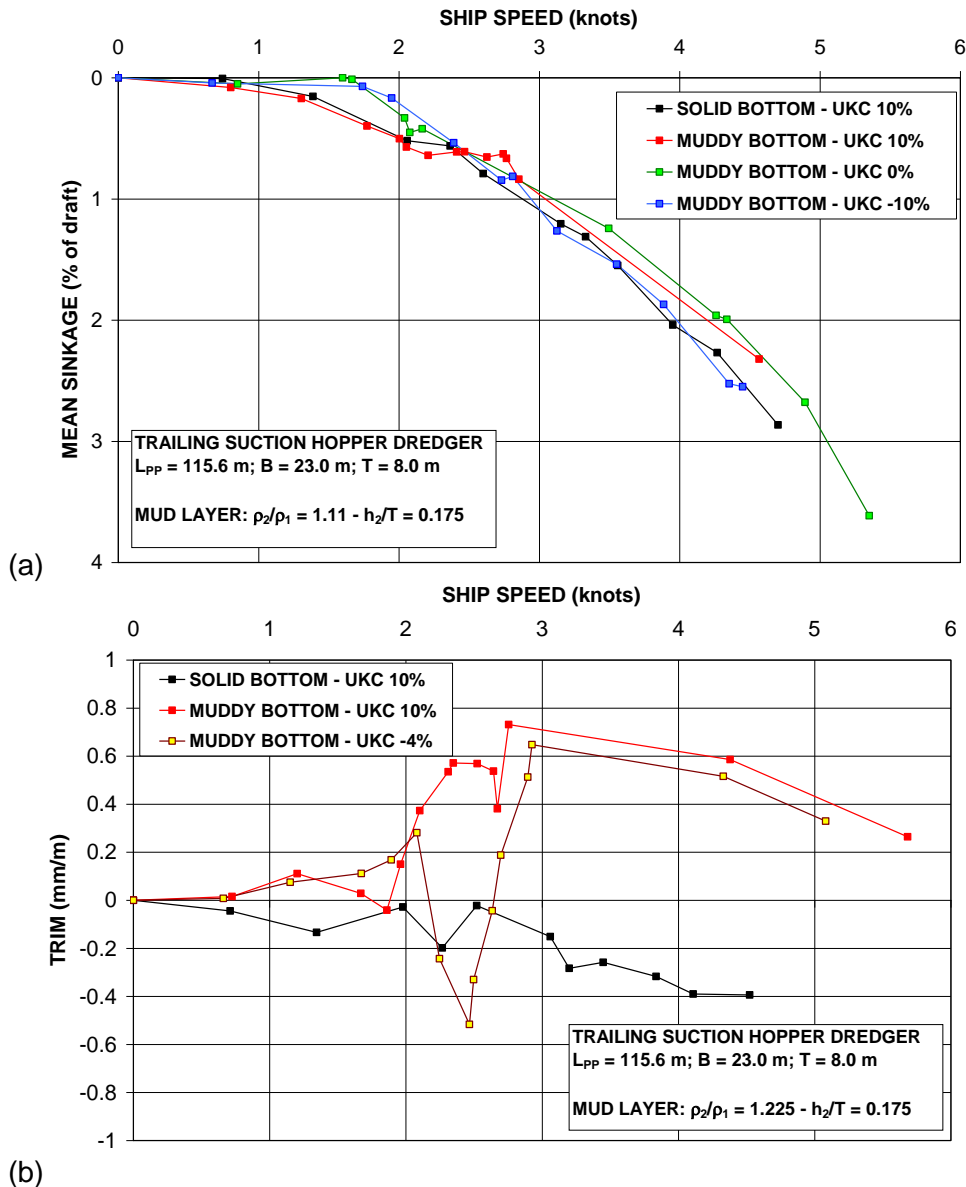

Figure D-17: Mean midships (a) sinkage and (b) trim as a function of UKC for a full-form trailing suction hopper dredger above a simulated mud layer, dredger 115.6 x 23.0 x 8.0 m³, scale 1/40, ($\rho_2/\rho_1 = 1.22$, $h_2/T = 0.175$). Positive trim is equivalent to increased stern squat [Vantorre, 1990]

D.6.5 Ship Stern Transoms

The BAW has experienced increased bow squat for some of the newer container ships with wider stern transoms sailing in the River Elbe. Above a speed of 11 knots, the ship starts to squat and trim strongly. However, once the transom-stern submerges below a draught of 12 m, the ship experiences greater buoyancy, which causes it to trim by the bow. This produces larger bow squat than ships without the wider transom-stern. Therefore, in extremely shallow water, the trim behaviour and the deepest point of a vessel (here the bow squat) clearly depend on the overall design of the underwater hull and especially on the buoyancy distribution in the longitudinal direction. This result indicates that, for these wider transom-stern ships, the use of the C_B may not be as reliable an indicator of squat as has traditionally been observed [Uliczka and Kondziella, 2006].

D.7 Numerical Modelling of Squat

The prediction of squat using empirical formulas was discussed in Section D.4. In many cases, however, these formulas may not be as accurate as numerical models, especially for newer generation ships and conditions for which the empirical formulas were not specifically developed. An example would be a ship sailing eccentrically in a canal or during a passing manoeuvre. Empirical formulas are generally faster and less expensive to use, but may run the risk of less reliability. In most situations, numerical models will probably give a more accurate prediction of ship squat.

D.7.1 Numerical Methods

Numerical modelling has made important progress as computer performance has increased. Briggs et al. (2010) summarised the different numerical modelling approaches for solving the ship squat problem. Numerical models for squat can be divided into three categories:

- slender body models
- boundary element models
- Computational Fluid Dynamics (CFD) models.

D.7.1.1 Slender-Body Models

Slender-body models are based on potential flow around a body in shallow water. The ship is divided into a number of sources along the length of the hull. The strength of these sources is relative to the change of the cross-sectional area over the length of the hull. Hence, the exact shape of the cross-sections is not considered and the method is only valid if the ship length is much greater than the beam and draught (which is the case for most ships). A further assumption is the potential flow assumption. This assumption is valid near the bow and near midship, where the fluid is accelerating or flowing constantly. However, the potential flow assumption is violated near the stern, where the fluid is decelerating near the water surface and there are significant effects of the propeller wash. This means that the bow squat is determined rather accurately, but the stern squat is underestimated, especially at higher speeds and for small UKC.

The pioneering work on squat modelling was carried out using slender body methods by Tuck (1966) for a ship sailing in unrestricted waters. The method was later extended to include the effects of channel banks [Beck et al., 1975]. This squat model is implemented in the BNT (Beck, Newman and Tuck) squat module that is incorporated in the UKC prediction model CADET. The dynamic squat effects during passing manoeuvres were investigated by Gourlay (2009) using a slender-body model.

D.7.1.2 Boundary Element Models

In boundary element models the submerged hull of the ship is discretised by a large number of quadrilateral or triangular panels. Similar to the slender body models, they are based on the potential flow assumption, but with the advantage that the exact shape of the hull can be considered and the flow underneath the ship can be computed. Furthermore, it is possible to consider other objects of arbitrary shape, such as channel banks, obstacles and passing ships. Similar to the slender-body models, the propeller wash and turbulence effects near the stern are omitted. Nevertheless, the correspondence between calculated and measured squat is good for a wide range of conditions.

The most straightforward models are based on the 'double-body' flow assumption. This means that the effects of water level fluctuations on the flow pattern are neglected. In other words, the flow is assumed horizontal near the water surface. The advantage of this approach is that the water surface can be assumed as a horizontal lid, so that no panels are required here. Double-body flow models are linear models. This implies that the calculated squat is proportional to the vessel speed squared. Improved nonlinear behaviour can be achieved by multiplying the result with the 'Tuck factor' which originates from the slender-body theory.

Free surface effects can play a role for ships sailing at higher speeds. In these cases Rankine panel models, such as GL RANKINE [Söding and Bertram, 2009], provide more accurate results. The water surface is also discretised by a large number of panels at which the nonlinear free surface condition is applied. The location of the water surface and the sinkage of the hull are obtained using an iterative solver.

D.7.1.3 Computational Fluid Dynamic (CFD) Models

With the increases in computing power, CFD model computations have now become viable for flow problems around large ships. Many commercial CFD models are available to calculate air or water flow around structures. However, few are devoted specifically to squat calculations. The advantage of CFD modelling over the two preceding potential flow methods is that viscous and turbulence effects are considered. This is a clear improvement for fine ships that experience stern squat. Good results can be obtained for a wide range of hull shapes as will be shown in Section D.7.2. The disadvantage of CFD modelling is the much more complex set-up of the models and the long computation times.

At the core of any CFD problem is a computational grid or mesh consisting of thousands of elements. The elements can be quadrilaterals or triangles in two dimensions and hexahedrons, tetrahedrons, or prisms in three dimensions. Mathematical equations are solved for each element by the numerical model. The Navier Stokes equations (NSE) provide detailed predictions of the flow field including turbulence, but require high CPU time, large memory storage and very thin meshes. Resolution for NSE codes is also difficult with numerical instabilities. Examples of commercial CFD models include *Fluent* and *Fidap*.

The computation domain has to be relatively small to solve ship squat predictions using NSE. This restriction can be overcome by dividing the problem into zones. Far from the ship the model solves a potential function with a non-viscous fluid and, in the vicinity of the ship, the model solves the NSE. The advantage of this method is that the potential flow requires low CPU time and less memory storage. The boundary conditions of the NSE are extracted from the potential flow solution. One example of this kind of commercial model is *Shipflow* from Sweden.

In very restricted water, squat can substantially reduce the vertical cross section around the ship, resulting in increased flow velocities below the hull. According to Bernoulli's principle, the ship sinks due to the decrease in pressure. Numerical models have to account for this 'over squat' to precisely estimate ship squat. The numerical model needs to 'check' that this squat is not disturbing the hydrodynamics in such a way that squat could increase and affect the accuracy of the predictions. This is usually not a concern for unrestricted channels with relatively large UKC given by $h/T > 1.1$, but becomes important for restricted and canal configurations with smaller UKC.

D.7.2 Modelling System to Predict Ship Squat

Debaillon (2005) developed a numerical modelling system with squat checking to reproduce the physical process of ship squat. As the ship moves, a return flow is generated around the hull. This induced velocity reduces the pressure under the hull. The ship sinks until pressure forces balance its weight. As the ship position changes, flow is updated with a new cycle of hydrodynamic and equilibrium computations. The modelling system is thus composed of (a) a hydrodynamic model to calculate the flow around the hull, (b) an equilibrium model to move the ship with balanced force and momentum equations, and (c) a mesh updating model to account for the ship and the free surface displacements (Figure D-18).

The hydrodynamic model is based on the finite element method and solves Laplace's equation in three dimensions to obtain the velocity potential function. The velocity components and the pressure at each node of the mesh are calculated and then input to the equilibrium model. This second model calculates vertical forces by integration of pressure over the hull. It estimates vertical motions due to heave, pitch, roll, and squat. The ship is then translated and rotated corresponding amounts. Finally, the mesh is updated in the third module according to this ship displacement and the free surface and ship nodes are moved proportionally according to boundary distance and modifications. Note that the squat predictions are only as good as the resolution of the mesh, so care must be exercised in defining the grid mesh. The interested reader can find additional details in the paper by Briggs et al. (2010).

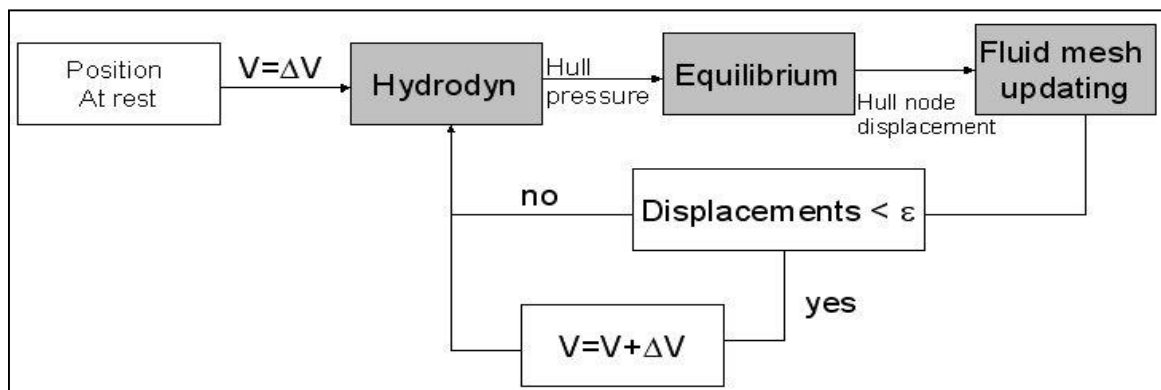

Figure D-18: Numerical modelling sequence where $V = V_s$ is ship velocity, $\Delta V = \Delta V_s$ is change in ship velocity and ϵ is displacement tolerance level.

D.7.3 Numerical Modelling Examples

The CFD numerical model of Debaillon (2005) was run for the example problems discussed in section D5. These examples included the SR108 container ship in an unrestricted channel, an FHR container ship in two positions in a restricted channel, and the Esso France tanker in the Suez Canal.

D.7.3.1 BAW Model Container ship in Unrestricted Channel

The mesh contained 59 493 nodes, 259 877 tetrahedrons, and 64 074 triangles. A general comparison between squat measurements, empirical formulas and the numerical model was shown in Figure D-8. The results of the numerical modelling agreed well with the measurements.

D.7.3.2 SR108 Container Ship in Unrestricted Channel

The mesh contained 38,840 nodes, 156,339 tetrahedrons and 50,762 triangles. A general comparison between squat measurements, empirical formulas and the numerical model was shown in Figure D-9. The results of the numerical modelling agreed well with the measurements.

D.7.3.3 FHR Container Ship in Restricted Channel

The mesh for case FHR 92 contained 47,259 nodes, 194,752 tetrahedra and 56,738 triangles and the mesh for case FHR 265 had 41,697 nodes, 172,035 tetrahedra and 49,912 triangles. Figure D-10 showed the comparisons.

D.7.3.4 Esso France Tanker in Suez Canal

The mesh contains 74,006 nodes, 259,582 tetrahedra and 62,974 triangles. Figure D-12 showed the comparison between squat measurements, empirical formulas and the numerical model. In general, the numerical modelling reproduces the bank effect and the experimental measurements very well.

D.7.3.5 Global Challenger Bulk Carrier in Canal

The mesh contained 41,816 nodes, 190,013 tetrahedrons and 38,404 triangles. A comparison between squat measurements, empirical formulas and the numerical model was shown in Figure D-13. The results of the numerical tended to under predict the bow squat measurements for this case.

D.8 Future of Squat Research

Research in squat predictions is a dynamic area of ship hydrodynamics with new experiments being conducted to compare formulas and develop new ones for the increasing size of ships. Flanders Hydraulics Research (FHR) in Antwerp, Belgium is actively studying the effect of manoeuvres, banks, interaction with other ships and fluid mud bottoms on ship squat by means of model tests. The Federal Waterways Engineering and Research Institute (BAW) in Hamburg, Germany studies squat due to passing and overtaking ships in restricted channels using physical models and field measurements. Preliminary findings indicate that the existing squat formulas are not very accurate for this next generation of larger, deeper-draught vessels in these interacting conditions.

PIANC recommends model tests for specific ship and channel conditions, especially if the conditions are new or novel [PIANC, 1997]. Many of these laboratory-based empirical formulas are from captive-towed tests that might introduce unintended moments that can cause unrealistic trim of the towed models. The current thinking is to use free-floating, remote-controlled models for physical model tests. The improvement and availability of positioning systems (DGPS) makes it possible to obtain more accurate and reliable squat measurements at full scale. In addition, numerical models are being developed that show promise as design tools.

Newer and significantly larger ships are coming on line and may experience squat differently from the relatively smaller vessels originally tested in these formulas. The larger 'transom' stern container ships are an example of how changes in ship design

affect ship squat. New research on passing and overtaking (BAW and FHR), fluid mud bottoms (FHR) and rippled bottoms (BAW) is being conducted. Numerical models are continuing to be developed and improved to include passing and overtaking, bank effects, muddy bottoms, non-uniform water depths, channel constrictions and bridge pile interactions. They have the potential to be more exact and accurate than the empirical formulas, especially in the DD stage of design. There will probably always be a place for the basic empirical formulas, especially in the early CD stage when a 'quick' answer is needed. In the final analysis, the operating channel authority will probably reach a compromise on required channel depth based on economic considerations as well as good civil engineering and port design practice.

10 APPENDIX E WATER DEPTHS IN MUDDY AREAS – THE NAUTICAL BOTTOM APPROACH

E.1 Introduction

The PIANC Working Group 30 defined the nautical bottom as “the level where physical characteristics of the bottom reach a critical limit beyond which contact with a ship's keel causes either damage or unacceptable effects on controllability and manoeuvrability.” Accordingly, the nautical depth was defined as “the instantaneous and local vertical distance between the nautical bottom and the undisturbed free water surface.”

The practical application of this definition requires insight in both the physical mud characteristics and the effect of the presence of mud layers on the behaviour of a ship. Basic information and descriptions were presented in Chapter 2 and Appendix D. In this appendix, additional details are given of both aspects.

E.2 Mud Characteristics

E.2.1 Rheology

In muddy areas, the definition of nautical bottom could be interpreted as the level where the navigable fluid mud ends and the non-navigable seabed begins. The physical parameter to be selected as a base for a practical determination should be related to the rheological properties of the mud, characterising its resistance to flow, deformation and structural changes.

A full characterisation of fluid or partially consolidated mud is very complex and depends on at least seven parameters or sets of influencing factors. These include: hydrodynamic and electrostatic forces; strength of inter-particle action; visco-elasticity; viscosity (zero shear and maximum viscosity of the fluid phase preventing sedimentation); size and shape of the particles and creep recovery [Claeys, 2006].

Rheology is graphically represented by a rheogram (flow curve), giving a relationship between shear rate $\dot{\gamma} = d\gamma/dt$ and shear stress τ . The slope $d\dot{\gamma}/d\tau$ of this curve is referred to as differential dynamic viscosity and the ratio $\dot{\gamma}/\tau$ is called apparent dynamical viscosity. For a Newtonian fluid (e.g. water) no difference exists between them, so that rheology is completely characterized by only one parameter, its dynamic viscosity μ (see Figure E-1). Mud rheology is far more complex and is, for engineering purposes, often simplified by means of a Bingham model that is rheologically determined by two parameters. These are (differential) dynamic viscosity η and yield stress or initial rigidity τ_0 , being the shear stress that has to be overcome to initialise material flow.

Figure E-1 shows that using a Bingham model to describe mud rheology implies a serious simplification. First, mud appears to be a visco-plastic or shear-thinning material, which means that the slope of a mud rheogram is not constant, but decreases with increasing shear rate. For this reason, a Herschel-Bulkley model is more appropriate to describe the flow behaviour of mud. Furthermore, different relationships are found with increasing and decreasing shear stress: a smaller shear stress is required to obtain the same deformation if the shear stress decreases. The latter is a consequence of thixotropy of the mud. Since shearing of the material results in the break-up of the original structure, liquefaction takes place causing a decrease of flow resistance. Expressed in a simplistic

way, mud behaves more like a liquid after it has been stirred. Another result of thixotropy, for different cycles of increasing and subsequently decreasing shear rate, the consecutive rheograms lie below the previous ones. On the other hand, when stirring is stopped, structural recovery will take place over some time and the yield stress increases again (consolidation). It can be concluded that the rheogram of a mud sample depends on its stress history (or rheological history).

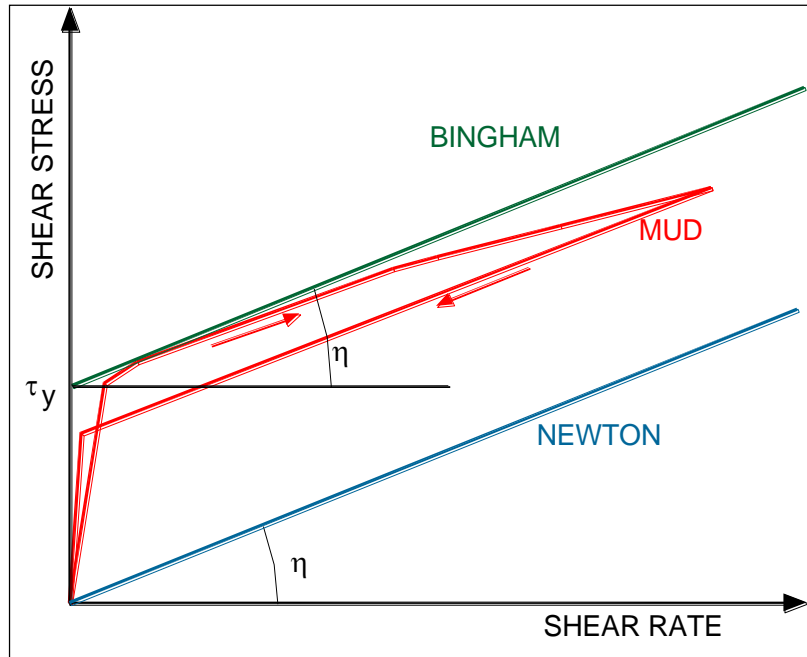

DEFINITIONS

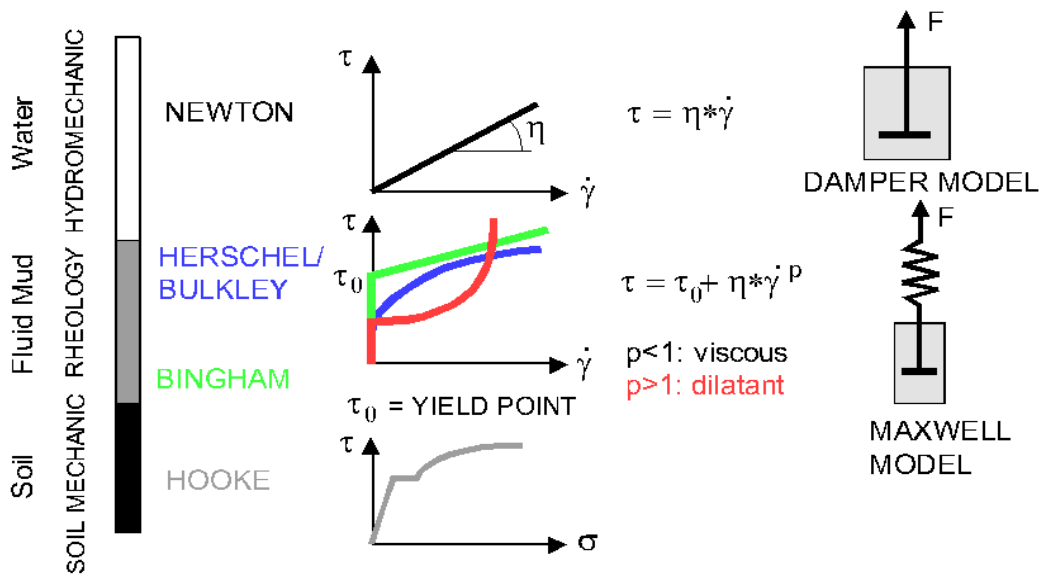

Figure E-1: Rheological properties of mud [Kerckaert et al., 1985 ; Wurpts & Torn, 2005]

E.2.2 Density

Another important physical property is mud density ρ_m , which is related to the relative amount of water and solid material in the mud. It is given by:

$$\rho_m = \rho_w(1 - \varphi) + \rho_s\varphi = \rho_w(1 - \varphi) + T_s \quad (\text{E-1})$$

where ρ_w and ρ_s are the densities of water and solid material (sediment), respectively; φ is the solids volume fraction and T_s is the concentration of solid material.

E.2.3 Density-Rheology Relationship

In general, yield stress increases with density: a larger fraction of solid material will lead to a more Bingham-like behaviour. On the other hand, density is not the only determining parameter, so that there is no unique relationship between density and rheology. Mud rheology also depends on many physical and chemical parameters such as sand content, spectrum of particle diameter, clay mineralogy, percentage of organic material, water chemistry (pH, salinity) and even (rheological) history and measuring technique. The effect of sand/mud and organic material content is shown in Figures E-2 and E-3. For the transition between sand and mud particles defined at 63 μm , Figure E-2 shows for a low sand fraction, the rheological properties increase much faster with density. Figure E-3 illustrates that the presence of organic material has a significant fluidising effect.

If all these parameters are given, an empirical relationship between yield stress and density can be determined, although this relationship is not unique. According to the density range, a distinction can be made between fluid and plastic mud (Figure E-4) defined as:

- Fluid mud with low solids fraction (low density) is a loose suspension similar to water (sometimes called 'black water') having a viscosity and yield stress that are not, or only slightly, dependent on density
- Plastic mud with a higher solids fraction (higher density) is a sediment deposit with non-Newtonian rheological properties that depend strongly on density. Besides viscous behaviour, this kind of mud shows elastic behaviour comparable to a soil. This combination is referred to as visco-elasticity (or elasto-viscosity).

This change in structural behaviour is called the rheological change-over or rheological transition.

Good examples of rheological and density profiles in loose mud deposits are shown as a function of depth in Figure E-5. Density appears to increase more or less gradually with depth, although sometimes steps are observed in which density hardly increases with depth. The initial rigidity curve, on the other hand, clearly shows the rheological transition level.

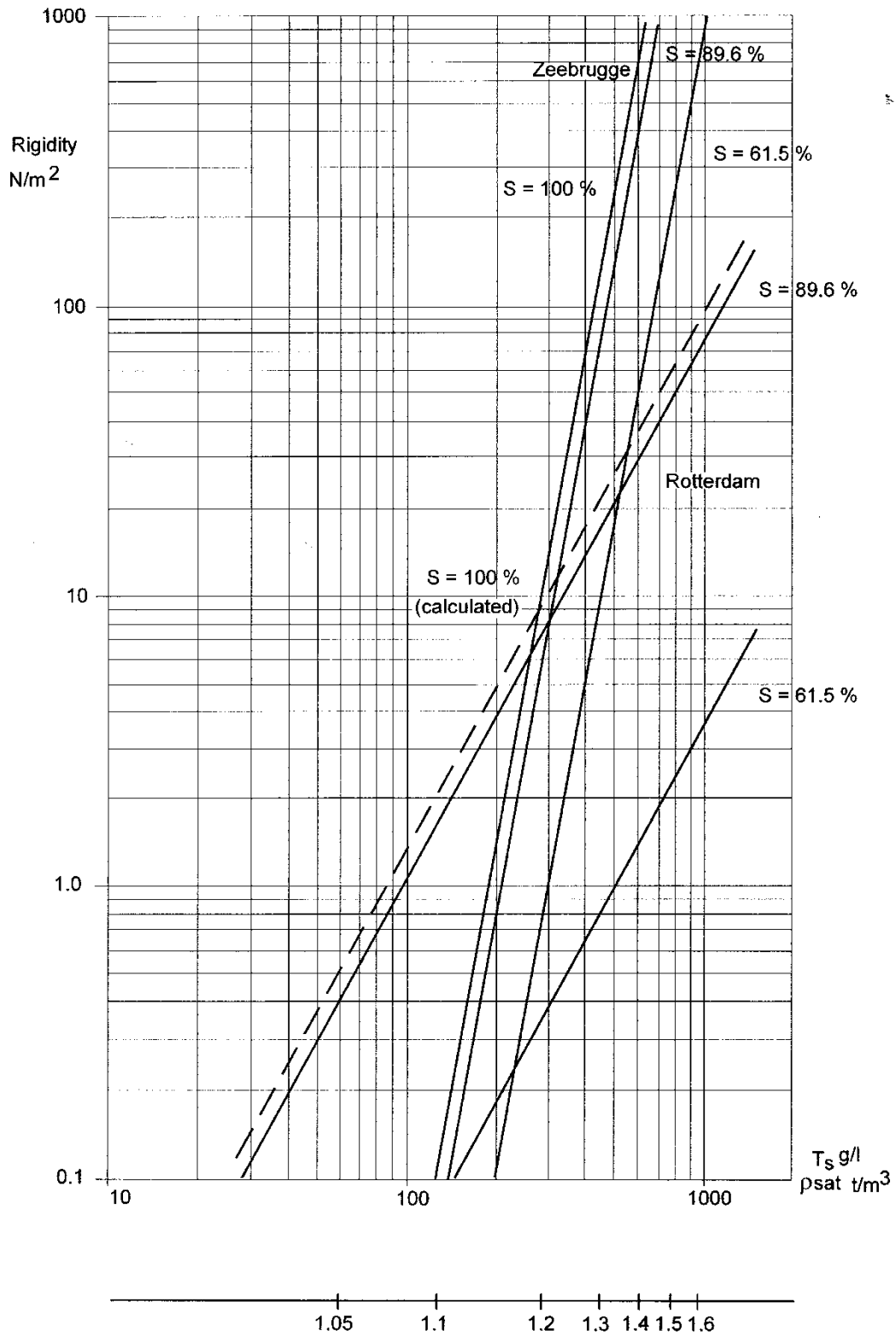

Figure E-2: Relation between rigidity and density for different mud compositions in Zeebrugge and Rotterdam;

S = mud content, T_s = concentration of dry sediment, ρ_{sat} = volume mass of saturated sediment, t_y = initial rigidity or yield stress (PIANC Working Group 3-a, 'Navigation in Muddy Areas', Permanent Technical Committee II, Bulletin No. 43, PIANC, 1982/83, pp. 21-28.)

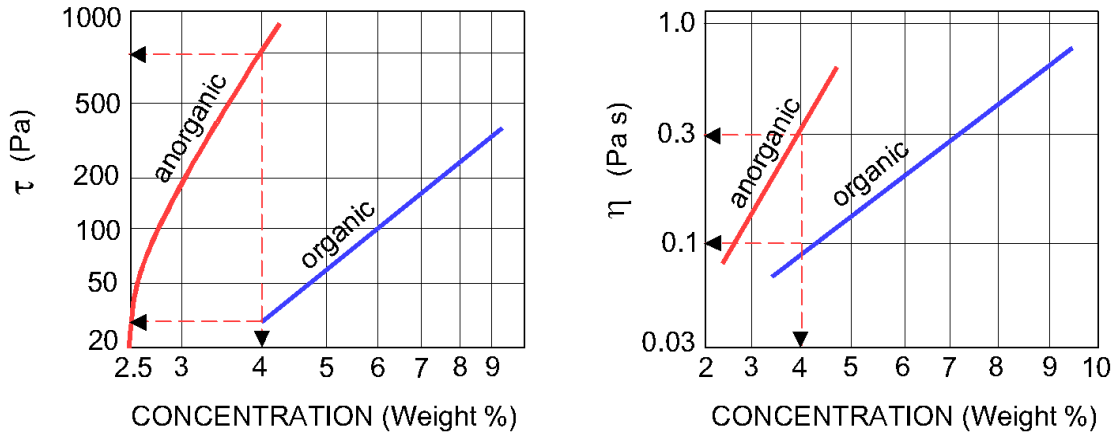

Figure E-10-3: Fluidising effect on mud [Wurpts, 2005]

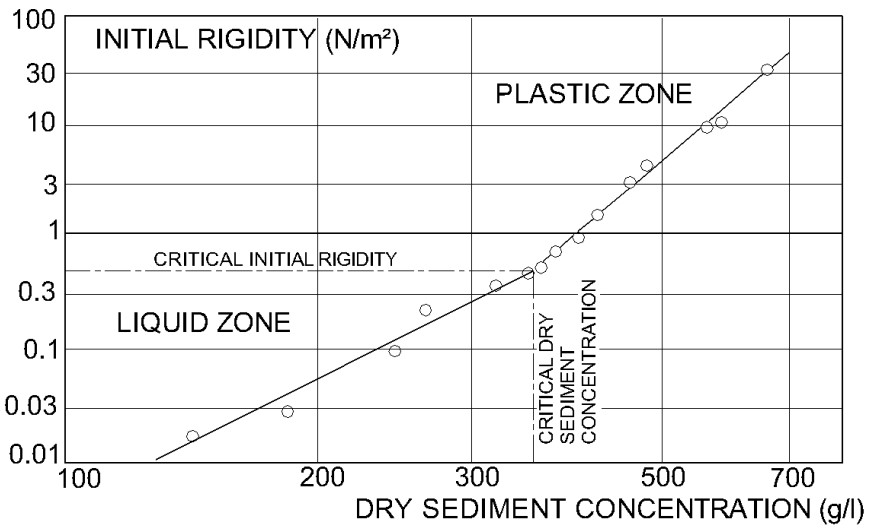

Figure E-4: Initial rigidity for dry sediment concentration [Galichon et al., 1990]

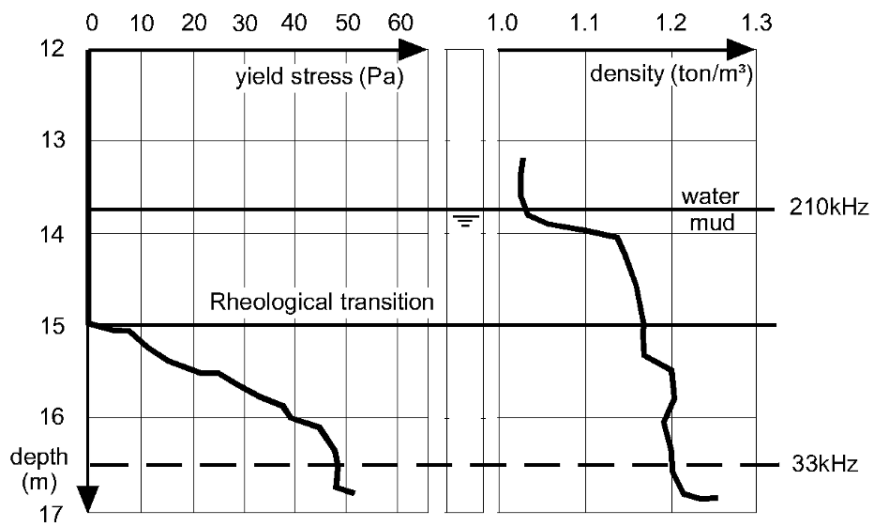

Figure E-5: Rheological and density profiles [De Meyer & Malherbe, 1987]

Sometimes more complex rheology-depth relationships may be observed. In the case of Figure E-6, a first, small rheological jump occurs less than 0.5 m below the water-mud interface while a second, more drastic transition is observed at a depth of 3 to 4 m under the interface. Above this transition, the mud is neither 'black water' nor plastic mud.

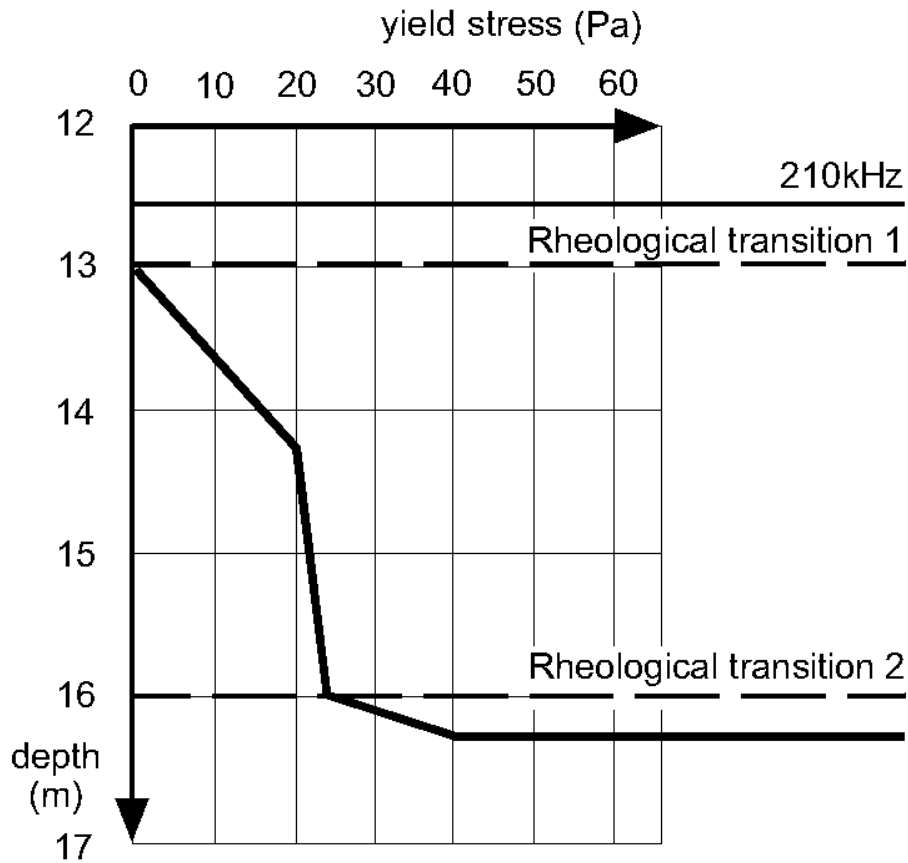

Figure E-6: Rheological-depth relationship [Vantorre et al., 2006]

E.3 Criteria for Determining the Nautical Bottom

E.3.1 Echo-Sounding Criteria

Echo-sounding gives a very useful qualitative indication of whether a fluid mud layer is present. High frequency signals (100-210 kHz) clearly indicate the interface water-mud, while low frequency levels (15-33 kHz) penetrate deeper into the mud layer (Figure E-7) and are normally reflected from the well-consolidated bed or hard bottom. Typical values for the difference between signals or levels vary from 0.3 m to several metres. A low frequency echo is often used to determine the nautical bottom. For instance, in the Harbour of Emden, the 15 kHz signal comes closest to the nautical bottom defined with rheological parameters. However, the applicability of such a criterion cannot be generalised and should be examined for each location, as seasonal and tidal fluctuations are possible. Reflection of low frequency acoustic signals in the mud appears to depend upon many parameters (gas bubbles, sandy horizons, density gradients, even experience of operator, etc.). Furthermore, as low frequency waves sometimes reflect at several levels, they do not always result in an unequivocal signal (see Figure E-8).

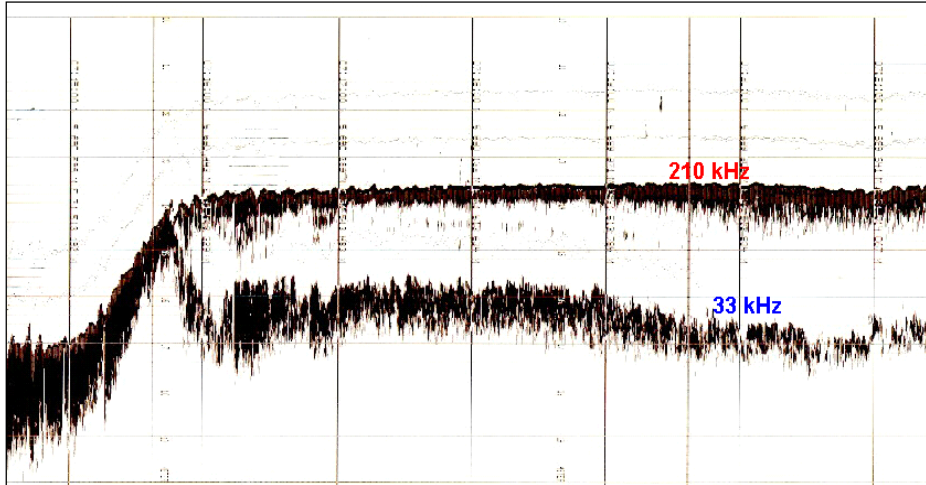

Figure E-7: Echo sounding penetration [De Brauwer, 2005]

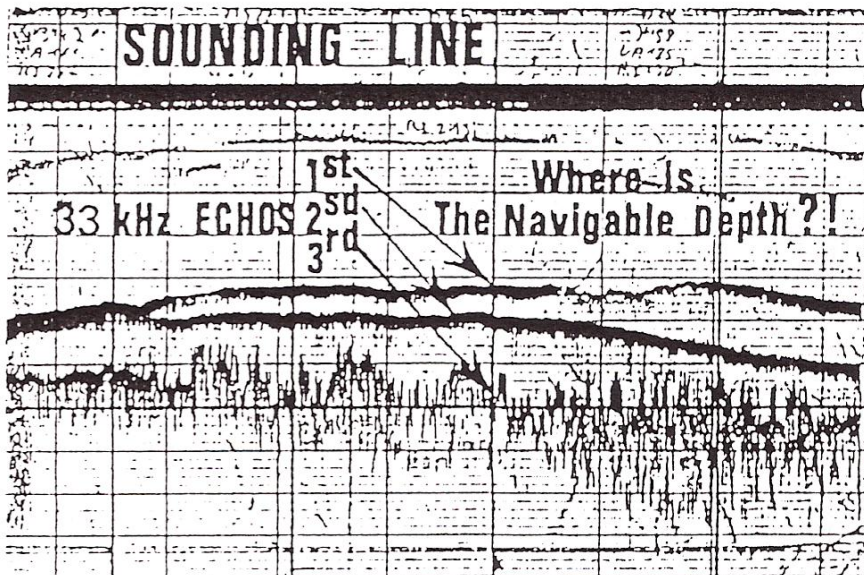
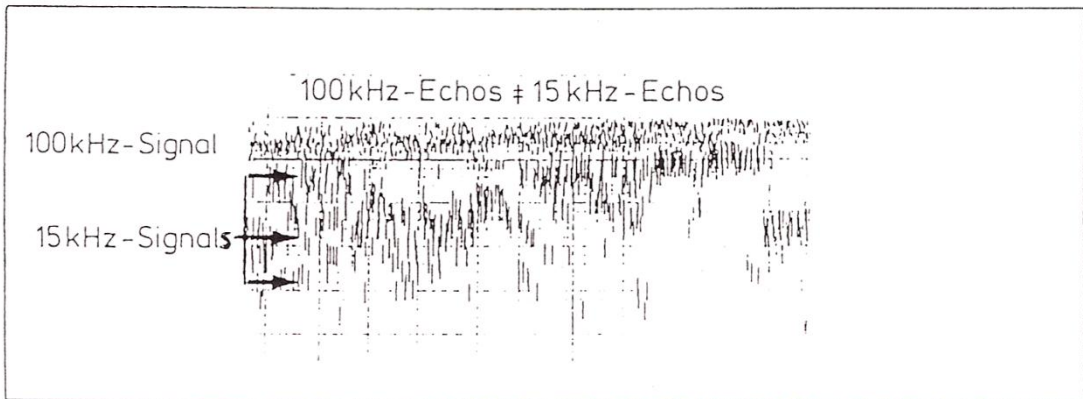

Figure E-8: Difficulties of low frequency echo sounding in muddy waters [Aster & Meyer, 1990 ; PIANC, 1989]

E.3.2 Rheology-Related Criteria

Ship controllability and manoeuvrability can be adversely affected by additional forces exerted by the interaction between ship and mud layer. Since the magnitude of these forces is related to the rheology of the mud, the theoretical definition of nautical bottom should be based on rheological properties of the mud layer. In fact, this is the case in practically all waterways where a nautical bottom approach is applied. Unfortunately, in situ rheological measurements can only be made by means of devices that have been positioned stationary in the horizontal plane. Furthermore, due to the complexity of the rheological behaviour of mud, the results of these measurements depend on the equipment and the analysis method. Vertical profiling and towed in situ rheological measurement techniques are still to be validated. As a consequence, the practical, routine determination of the nautical bottom is seldom made based on rheological measurements. Most of the historical and recent survey methods are based on the simpler and easier to measure density parameter.

In some cases, a critical value of a rheological parameter is selected to determine the nautical bottom. For example, in the access channels to several German harbours, a dynamic viscosity of 10 Pa·s is used as a criterion. The corresponding density values vary from 1,100 to 1,250 kg/m³ [Uliczka and Liebetruh, 2005]. In the outer Harbour of Emden, on the other hand, a yield stress of 100 Pa at the yield point (i.e. the point in the rheogram with maximum viscosity, see Figure E-9) is accepted as the nautical bottom. Still, one must be careful to use the absolute values of viscosities or yield stresses. These values can only be compared when a good international laboratory measurement protocol and sampling is set-up.

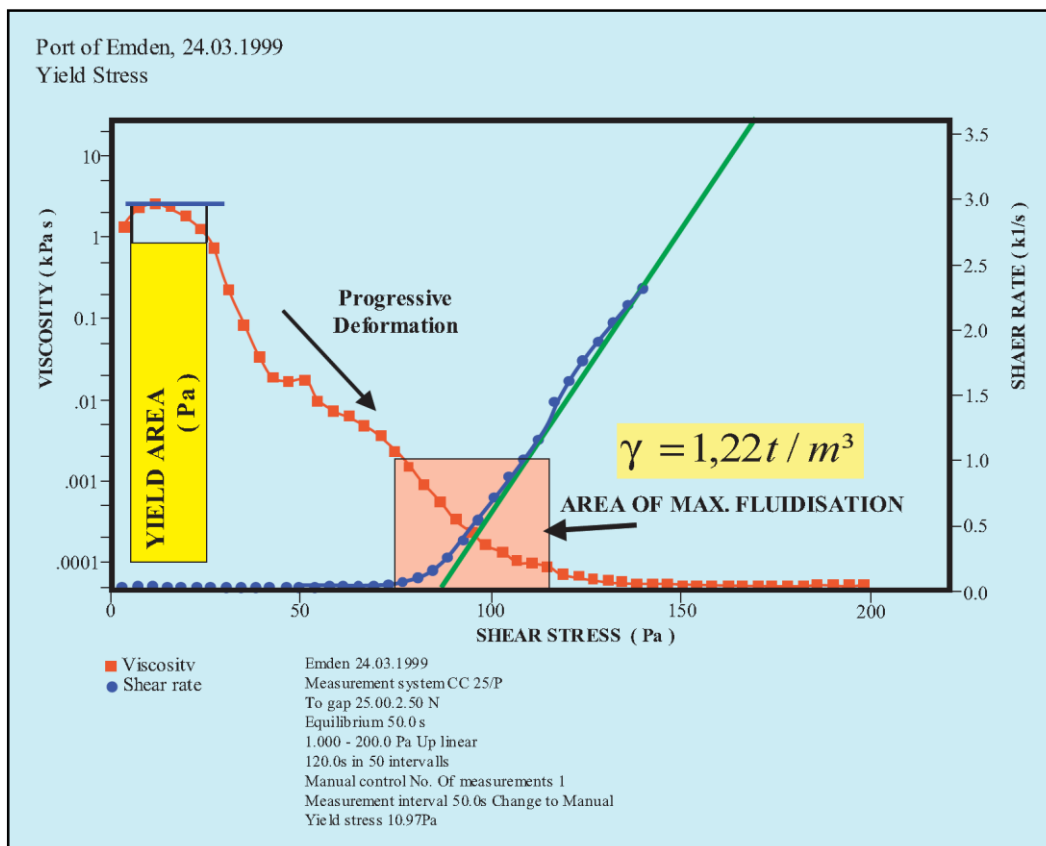

Figure E-9: Viscosity and shear stress as a function of shear rate for mud in the Port of Emden [Wurpts, 2005]

Instead of using a critical value for a rheological parameter, a theoretical definition of the nautical bottom is often based on the relative rheological transition level. This approach offers several practical advantages. On one hand, this level usually corresponds with a very low yield stress (< 10 Pa) and can therefore be considered conservative. On the other, as the rheological properties increase very quickly with depth near the transition level, it can be expected that a substantial increase of depth would lead to unacceptable yield stress values, so that this level can be considered as economically acceptable.

Nevertheless, some objections in principle can be raised against the use of the rheological transition level. First, the rheological transition is not really situated at a specific level, but rather indicates a transition range. Second, a definition making use of this level is only based on mud properties since the influence on ship dynamics and behaviour is not considered. Finally, even when operational procedures for determining the nautical bottom are actually based on the rheological transition level, the practical determination uses density measurements.

E.3.3 Ship Behaviour Criteria

The nautical bottom can only be defined if the reaction of a ship touching this level is known. In this respect, the nautical bottom should be defined only if the ship behaviour is included. On the other hand, the degree of acceptance of ship controllability and manoeuvrability depends on a huge variety of objective and subjective parameters including local environmental conditions, degree of training and expertise of the pilots, availability of tug assistance, quality of aids to navigation and economic considerations.

As an example of such an approach, a research project based on captive ship model tests, mathematical modelling and real-time simulation runs resulted in an upper limit for the nautical bottom and guidelines for the pilots concerning handling of deep-draught container vessels in the muddy conditions of the Zeebrugge Harbour. Unfortunately, the conclusions and definition of the nautical bottom are only valid for the particular conditions (harbour layout – determining the way the ship's manoeuvrability is challenged, ship types, mud layer characteristics, current, wind, tug assistance, human control, aids to navigation, etc.) that have been investigated. This approach offers the important advantage that the new criterion for the nautical bottom is not based solely on one single physical property of the mud layer, but has been determined based on all significant factors. On the other hand, for the practical determination of the nautical bottom, physical properties of the mud layer have to be selected for setting criteria.

E.3.4 Mud Density Level Criteria

Since several survey systems are available for the continuous measurement of sediment density, most operational procedures for determining nautical bottom are based on a value for the acceptable specific gravity of the mud (i.e. density of the mud divided by the density of water). Unfortunately, the critical mud density value depends on the location and rheological properties are not pure functions of density. As a consequence, the choice of a critical density level is based on considerations of the rheological properties of the local mud. This leads to the following disadvantages:

- The critical density defining the nautical bottom depends on the location, so that it is not possible to establish a universal value
- At a given location, mud characteristics can be variable (e.g. residence/consolidation time, seasonal effects), so that the critical density must be changed frequently

- For practical reasons, a critical density value has to be selected to determine the nautical bottom for a given navigation area. Such a selection is always a compromise between safety and economics.
- If for safety reasons the lowest observed critical density is selected, it is doubtful that the proposed density also represents the most economical solution
- Occasionally, the density profiles show steps in which density is barely changed over several metres depth (see Figure E-5). This implies that the association of the nautical bottom to a density value can lead to uncertainties.

Although towed density probes can be used in a continuous way, it is not always possible to use them in this mode. This is especially true if the density horizon to be detected by the probe is located close to the rheological transition level, which is, of course, the purpose. There is a risk that the probe gets stuck in the mud layer and eventually lost. In these conditions, such probes can only be used for point measurements.

Several techniques exist to measure sediment density in situ. According to the measuring principle, a distinction can be made between [Claeys, 2006]:

- Remote sensing (non-physical profiling)
 - Echo sounding (acoustical density profiling, based on acoustical impedance transitions)
- Profiling point measurement devices
 - Gamma-ray based instruments
 - Tuning fork based instruments
 - Acoustical based instruments (speed of sound, attenuation).

E.3.5 Actual Practice

E.3.5.1 Belgium

The harbour of Zeebrugge, on the Belgian North Sea coast, has been subject to siltation ever since major harbour extensions and two breakwaters were constructed in the early 1980s. In the outer harbour, a fluid mud layer is constantly present with a thickness up to 3 or 4 m.

In the 1980s, it was decided to consider the 1,150 kg/m³ density horizon as the nautical bottom, based on a comprehensive density and rheology measurements. The selected density value was considered to be a safe criterion for the nautical bottom as the rheologic transition level was never located above this horizon. In addition, full-scale and laboratory tests with the hopper dredger *Vlaanderen XVIII* were conducted with both small positive and negative underkeel clearance (UKC) relative to the mud-water interface.

In 1997, a density-rheology survey showed that the rheological characteristics of the mud layer had changed significantly. Instead of one clear rheologic transition level, a more complex density-rheology relationship was observed. A first, small rheological jump occurred just below the water-mud interface while a second, more important one occurred at a depth of 3 to 4 m under the interface, corresponding with a density that was significantly higher than 1,150 kg/m³. As a result of a comprehensive research project (Flanders Hydraulics Research & Ghent University) consisting of model testing and real-time simulations, 1,200 kg/m³ is now used as a critical density to define the nautical bottom. A number of additional conditions were also recommended:

- Assistance of at least two tugs of 45-tonne bollard pull is required for deep-draught container carriers
- Navigability through lower density mud layers ($1,100 \text{ kg/m}^3$) is constrained to -7 % of UKC
- Pilots must receive updated information on the levels of the mud-water interface and the nautical bottom
- Pilots must be aware of the modified controllability of a ship navigating with reduced or negative UKC relative to the mud-water interface, and should receive an appropriate training.

At present, the $1,200 \text{ kg/m}^3$ density level is displayed as the nautical bottom on nautical charts of the outer harbour of Zeebrugge. The 210 kHz echo, tracking the mud-water interface and the 33 kHz echo are also measured and used as additional information by the pilots. In other harbours and waterways where mud layers are much thinner, the 33 kHz echo is often used to determine the nautical bottom.

The feasibility of rheologic survey equipment is being investigated at present, both in situ and at large scale in laboratory conditions.

E.3.5.2 France

In the muddy sections of the Loire and Gironde estuaries, giving access to the ports of Nantes-Saint-Nazaire and Bordeaux, respectively, the $1,200 \text{ kg/m}^3$ level is accepted as the nautical bottom as, on the average, this density corresponds to a rheological transition level. If no mud is present, single and multi-beam ultrasonic techniques are used to determine the bottom level.

The port of Nantes-Saint-Nazaire makes use of a gamma rays based density probe of the JTD3 type. Experiments to substitute gamma rays by X-rays are going on, as the latter require less protective measures.

E.3.5.3 Germany

In the access channels to German harbours, a dynamic viscosity of 10 Pa is used as a criterion for determining the nautical bottom level. The corresponding density values vary from $1,100$ to $1,250 \text{ kg.m}^{-3}$ [Uliczka and Liebethuth, 2005].

In the harbour of Emden, the nautical bottom appears to coincide with a yield stress value of 70 Pa; there are indications that a value of 100 Pa is acceptable as well. This level can approximately be detected by very low frequency echo soundings (15 kHz). The use of density as a criterion leads to a conservative approach; the nautical bottom may occur at density values that are considerably higher than $1,200 \text{ kg/m}^3$.

E.3.5.4 The Netherlands

In the harbour entrance of the ports of Rotterdam and IJmuiden, the $1,200 \text{ kg/m}^3$ density level is used as a criterion for determining the nautical bottom. This level is measured by means of point measurements with a gamma ray based instrument. Research is carried out by Rijkswaterstaat for selecting a series of instruments which allow a reliable and accurate determination of this critical density level. Recent experiments have shown that the results of density measurements by means of different instruments may vary considerably, and that the suitability of some instruments may be location dependent.

E.3.5.5 United States

Herbich et al. (1989) conducted a survey of U.S. ports and United States Army Corps of Engineers (USACE) Districts to evaluate the number of harbours and channels experiencing fluid mud conditions and determined that “a high percentage of responses clearly indicated that many U.S. ports experience fluid mud problems and presently no uniform procedure to accurately define the channel depth is practiced.” He also reported that ‘the navigable’ or ‘nautical’ depth concept is practiced unofficially in many U.S. ports as the pilots guide ships through channels that contain fluid mud layers. However, there have been no criteria developed, either in terms of density, shear strength of fluid mud, or in terms of frequency setting in echo-sounding equipment, that adequately define the navigable depth.

Conventional hydrographic surveying in areas with fluid mud can often result in ambiguous depth measurement due to its effects on mechanical (leadline) and acoustic measurement techniques. The USACE had recognised these effects as early as 1954 [USACE, 1954], when it unsuccessfully attempted to determine nautical depth by correlating depths measured by lead lining and echo sounding. The USACE has investigated nautical depth measurement using towed devices in the past [Alexander et al., 1997 ; Teeter, 2002] and is currently evaluating other established and emerging fluid mud measurement technologies, nautical depth definitions and project management practices for potential USACE implementation of a nautical depth policy [Welp et al., 2003].

E.4 Behaviour of Ships in Muddy Areas

E.4.1 Causes of Changed Behaviour

Ship behaviour (resistance, manoeuvrability, propulsion, etc.) in mud layers is mainly affected by:

- Rheological properties of the mud, which are responsible for additional forces on the ship's hull
- Generation of internal undulations at the interface between water and mud. These undulations depend on properties of the mud, such as density and layer thickness, and the ship, such as draught, UKC and forward speed.

In general the first cause is important when the ship's keel comes in contact with the mud layer; whereas, the second affects the ship's behaviour even if no contact occurs. Nevertheless, interactions between both causes are possible: for example, the mud rheology will also affect the undulation pattern caused by a ship navigating with a small positive under keel clearance relative to the interface.

E.4.2 Internal Undulations at the Interface (Internal Waves)

Vertical interface motions induced by a ship navigating above a fluid mud layer are speed dependent. Typically, a limited interface sinkage is observed under the ship's bow, changing into an elevation at a certain section along its length. The height of this internal hydraulic jump increases and its position moves aft with increasing speed. An approximate value for the critical speed separating the second and third speed ranges is displayed in Figure E-10 as a function of the ratio ρ_m/ρ_w between the mud and water densities, for different values of the water depth h_1 , measured above the interface

between water and fluid mud. The transition is observed to take place at a higher speed above more viscous layers, however. The undulation pattern changes when the ship's keel penetrates the mud layer with two observed maxima, one amidships and a second aft (see Figure E-11), as a function of layer thickness h_2 .

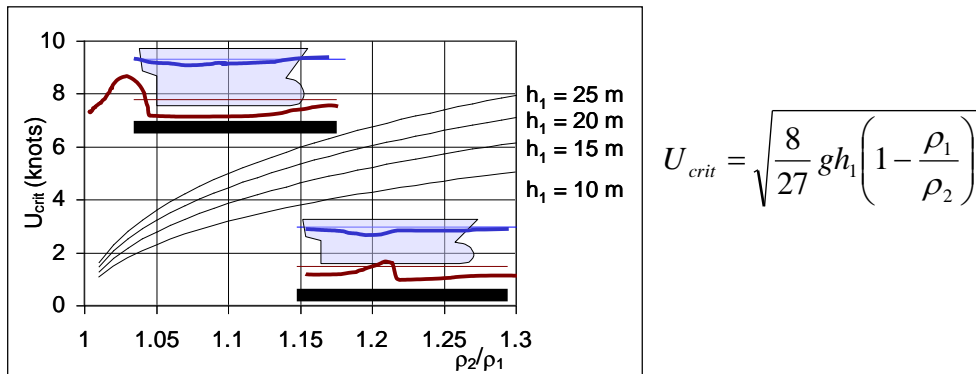

Figure E-10: Critical speed ranges as a function of $\rho_m/\rho_w (= \rho_2/\rho_1)$, for different values of h_1 . Theoretical value, valid for small viscosities ($< 0.1 \text{ Pa s}$) [Vantorre, 2001]

E.4.3 Resistance and Propulsion

A ship's resistance increases with decreasing UKC, as is the case above a solid bottom. A ship touching a higher density mud layer will undergo a sharp increase in resistance. In the case of a fluid mud (i.e. low-density) layer on the other hand, the interface does not appear to be a strict boundary. This can be explained by the internal wave system and the corresponding contact of the ship's keel with both water and fluid mud for a certain UKC range. Once the ship's keel fully penetrates the mud layer, the resistance increases again.

A ship's performance not only depends on the resistance, but also on the propulsion characteristics. The longitudinal force acting on the ship due to propeller action depends on the propeller thrust and thrust deduction factor. The larger the thrust deduction factor, the smaller the fraction of the thrust that is useful for the ship's propulsion. A larger value for this factor – which implies a smaller longitudinal force for a given thrust – is obtained at positive UKC values relative to the interface with high density mud layers. On the other hand, if the ship's keel touches the mud, the thrust deduction factor is larger for the lightest mud layers.

The propeller thrust is determined by the propeller rate and the axial inflow velocity. The latter depends on the ship's forward speed and wake factor. A larger value for this factor implies a smaller inflow velocity and, therefore, a larger propeller loading. The wake factor is clearly affected by bottom conditions:

- It increases with decreasing mud density, which implies an obstruction of the flow to the propeller. This phenomenon can be ascribed to the vertical interface motions
- It decreases if there is contact between the ship's keel and higher density mud layers as this causes an inflow of two fluids into the propeller, resulting into higher thrust and torque.

In general, the presence of mud on the overall efficiency of the propeller causes a significant loss of efficiency, especially for negative UKC.

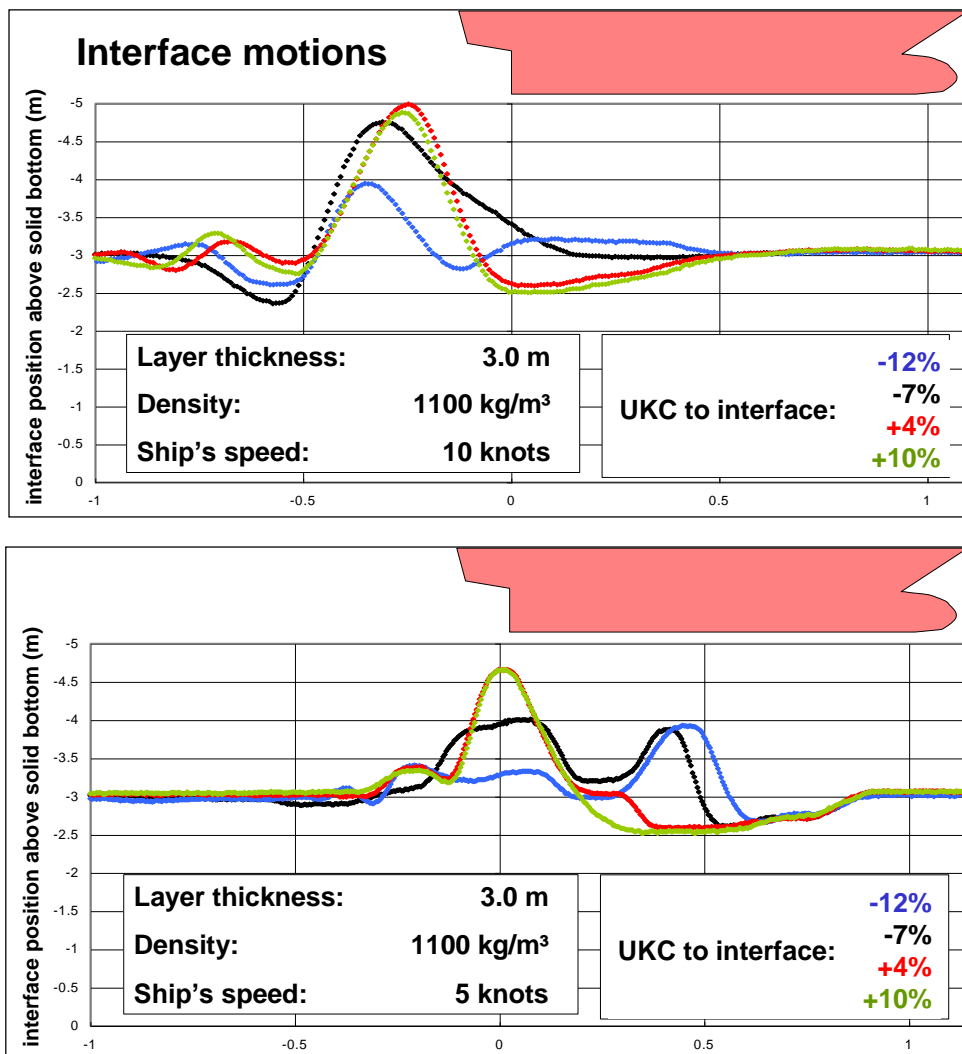

Figure E-11: Undulations of the interface between water and fluid mud, for two speed values and several underkeel clearances. UKC is expressed relative to the mud-water interface and is negative when the ship's keel is penetrating into the mud layer [Vantorre et al., 2006]

The propeller thrust is determined by the propeller rate and the axial inflow velocity. The latter depends on the ship's forward speed and wake factor. A larger value for this factor implies a smaller inflow velocity and, therefore, a larger propeller loading. The wake factor is clearly affected by bottom conditions:

- It increases with decreasing mud density, which implies an obstruction of the flow to the propeller. This phenomenon can be ascribed to the vertical interface motions
- It decreases if there is contact between the ship's keel and higher density mud layers as this causes an inflow of two fluids into the propeller, resulting into higher thrust and torque.

In general, the presence of mud on the overall efficiency of the propeller causes a significant loss of efficiency, especially for negative UKC.

E.4.4 Manoeuvrability

For a solid bottom, the manoeuvrability of a ship is adversely affected with decreasing UKC. The ship becomes more sluggish due to increased hydrodynamic inertia and yaw and sway damping forces. Characteristics of turning circles increase, while rate of turn and drift in a turn decrease. The overshoot angles during zigzag manoeuvres decrease. The ship's course stability increases.

Similar phenomena are also observed if the UKC relative to a mud-water interface decreases. The effects will even be stronger in the case of muddy bottoms, as lower UKC values are more acceptable relative to a mud-water interface than to a solid bottom. The effects are most significant for a very small positive UKC value. As an example, turning circle diameters reach a maximum for a small positive UKC above the interface. If the ship penetrates the mud layer, the effects will be reduced, so that a limited penetration into a low-density, fluid mud layer may often be preferable to a small positive UKC above the interface.

However, further penetration will have an adverse effect on the ship's controllability. A safe UKC with respect to the nautical bottom needs to be observed, as a ship navigating with the keel in contact with a plastic consolidated mud layer sometimes becomes uncontrollable and chooses the 'path of least resistance'. At the same time, it is practically impossible to decrease the ship's speed, even though only 1 or 2 knots.

The following results are of interest for a better insight into the physical mechanisms affecting a ship's behaviour in muddy navigation areas:

- Hydrodynamic inertia ('added mass') terms for sway and yaw increase significantly with decreasing water depth and increasing density and viscosity of the mud layer. If the ship's keel penetrates deep into the mud, values up to seven times the ship's mass are observed. This implies that an equivalent mass equal to eight times the ship's own mass needs to be accelerated to induce a lateral motion of the ship. The layer characteristics appear to be important parameters, even if no contact occurs with the mud layer. For a constant (positive or negative) underkeel clearance referred to the mud-water interface, the shallow water effect is lessened with increasing layer thickness and decreasing mud density and viscosity. Indeed, an abrupt transition cannot be observed at $h_1/T = 1$
- The magnitude of lateral force and yawing moment due to drift increases significantly with decreasing water depth. However, this increase appears to stagnate when the keel touches the interface since penetration into the mud layer hardly result in a further increase. For a given positive UKC relative to the interface, the presence of a mud layer appears to minimize the shallow water effects, especially for layers with low density and viscosity. On the other hand, if the UKC relative to the hard bottom is assumed to be constant, the presence of a mud layer will always have an adverse effect.

The forces and yawing moment caused by rudder action depend on axial flow into the rudder. The yawing moment is a function of the forward speed, propeller rate and rudder wake factor. It is significantly affected by bottom condition and the UKC. The wake factor decreases and, consequently, the flow to the rudder improves with increasing mud density and with increasing UKC. There are indications that the inflow to the rudder is affected unfavourably when the ship penetrates deep into soft, low-density mud layers.

11 APPENDIX F: AIR DRAUGHT

This appendix includes tables for estimating vertical air draught clearance *ADC* in Detailed Design for container ships, cargo ships, oil tankers, RoRo, PCC, LPG, LNG and passenger ships. The *ADC* is similar to the *UKC* for bottom clearance in water. The values are based on the coverage rate formulas and procedures used in Japan. Some of the material in this appendix is complementary to that in Appendix C, especially Tables C-1 and C-2.

F.1 Introduction

Dimensional values related to the height of ships are rarely indicated in the international literature. Possible reasons for this include:

- The number of available data on ship height is remarkably small in comparison with other dimensions such as L_{oa} , T , etc. For example, in the fundamental data for cargo ships (which represent the largest number of ships in analysis), the number of available data on ship height is only about 10 % of that for L_{oa} , T , etc.
- The reliability of values obtained from fundamental data related to ship height is low. The data contain numerous deviations and also include a large number of anomalous values. Because there is no clearly-defined concept of ship height analogous to that of L_{oa} , it can be supposed that there are errors in recording ship height by persons supplying the data. Therefore, the results of statistical analysis based on these fundamental data are open to question. Consequently, it is not possible to apply statistical analysis method to ship height.

On the other hand, because dimensional values for ship height are extremely important when designing bridges over fairways, arranging the relationship with the Obstruction Assessment Surface (OAS: height of ships and other obstructions which must be cleared by aircraft) in maritime airports and similar problems; indications of the dimensional values for ship height similar to those for L_{oa} and T has been an urgent requirement for many years.

Therefore, the first objective of the present Japanese research was to propose height dimensions for ships with the same accuracy as other main dimensions by solving these concerns in the follow manner.

- The dispersion of data on ship height and data on other dimensions was analysed by ship class and it was confirmed that there were no deviations in the distribution of the data for ship height corresponding to ship class. The aim of this analysis was to make it possible to obtain the same accuracy as the other dimensions, even though the number of data is much less for ship height
- New data for analysis of dimensional values were constructed by statistically eliminating anomalous values from the data. The aim here was to make it possible to obtain analytical results having high reliability, even though the number of data was reduced
- The inappropriateness of the statistical analysis technique used with L_{oa} , T , etc. to ship height was reconfirmed. Based on this, one aim of this work was to apply a new statistical analysis technique which makes it possible to obtain appropriate analytical results.

In addition, because the height from the water surface to the highest point on the ship is a practical necessity when designing bridges over fairways and arranging relationships with OAS at marine airports, the second objective of this research was to propose a table of dimensional values for the height of ships from the water surface. In summary, the objective was to (a) construct a technique for analysing the height from the water surface to the highest point on ships, (b) build a dataset of ship heights and air draughts by analysing new and previous [Takahashi, 2007] research results and (c) ensure high reliability by applying two analysis techniques. In summary, the procedure from this research can be used if actual air draught clearance values for the design ship are not known.

F.2 Air Draught Clearance (ADC)

As shown in Figure F-1, two different heights can be used to describe ship height. These include the height H_{kt} from the keel to the top (highest point) and the height from the sea or water surface to the top H_{st} , which is called 'air draught'. The water surface should include the highest probable navigable water level (e.g. high water datum such as HAT and/or tidal surge) due to tides and meteorological effects so that the air draught is correctly predicted. Of course, T is the ship's draught.

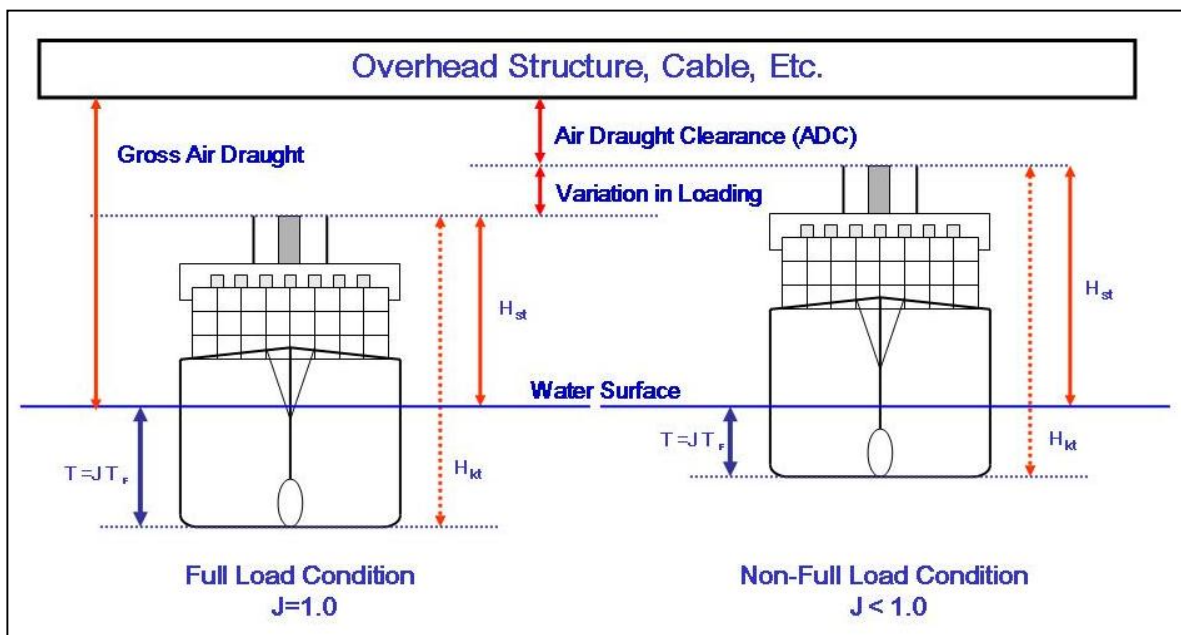

Figure F-1: Variation in air draught clearance as a function of ship loading condition [Takahashi, 2007]

The relationship among these variables is expressed by:

$$H_{st} = H_{kt} - T = H_{kt} - JT_{FL} \quad (F-1)$$

where:

- J = Draught factor, varies from 0.5 to 1.0 according to draught
- T_{FL} = Full-load draught (m)

The values of H_{kt} and T_{FL} of an assumed design ship are basically invariant. However, the actual draught $T (= JT_{FL})$ of a ship changes during navigation depending on the loading condition and other factors. The J factor is applied to account for changes in loading. It

will have a maximum value of 1.0 when the ship is in a fully-loaded condition and will be less than 1.0 when less than fully-loaded. For ballast conditions, $J = 0.5$ for weight carriers to $J = 0.8$ for volume carriers (see 1.3.4.3). The H_{st} increases as J decreases, so that as the ship's draught becomes less, the clearance between the top of the ship and overhead structures such as bridges becomes smaller and may pose a danger. As a result, the H_{st} will also vary from full load to lighter load conditions. Finally, the gross air draught is the vertical distance from the water surface to the bottom (or lowest part) of the overhead structures. The ADC is what is left for clearance after the H_{st} and variation in ship loading is subtracted from the gross air draught.

For safety reasons, there should always be a positive distance or ADC between the top of the ship and the bottom of any overhead structure. A new development affecting ADC is that naval architects and ship designers have started to make pieces of equipment on the tops of ships (antennas and radar devices) foldable when passing beneath an overhead structure.

F.3 Concept Design

As discussed in Chapter 2 (2.3.3 and Table 2.2) and repeated here for completeness, an estimate of the ADC in the Concept Design phase can be approximated as:

$$ADC = 0.05H_{st} \geq 2 \text{ m} \quad (\text{F-2})$$

Also, for outer channels where wave conditions can be significant, an additional allowance equal to 0.4 T should be included. The ADC must account for sag in power lines and additional clearance due to arcing of power lines. Obviously, for safety reasons, there should always be a positive distance or ADC between the top of the ship and the bottom of any overhead structure.

F.4 Detailed Design

F.4.1 Japanese Statistical Analysis of Air Draught H_{st}

A more thorough analysis of ADC would involve a careful examination of the heights in Eq. F-1. Japanese researchers performed an extensive statistical analysis of the air draught H_{st} in 2007 (Takahashi) that constitutes the Detailed Design phase for calculating ADC . The data used in the statistical analysis were the Lloyd's Register Fairplay Data for September 2006 (hereinafter, LRF Data). The LRF Data consists of 200,000 cases covering ship and port data that includes (a) 158,000 vessels of 100 GT or more, including newly constructed ships, existing ships and scrapped ships and (b) information on shipping lines, maritime disasters, ports and harbours, etc. For the present research, the authors obtained approximately 800 data entries on H_{kt} (mast, or stack or other highest point).

Table F-1 show Takahashi's results (2007) when H_{st} was calculated by ship type (container ships, cargo ships, oil tankers, RoRo, PCC, LPG, LNG and passenger ships) for varying H_{kt} , T_{FL} , and J from 1.0 to 0.8 (increments of 0.05) using coverage rates of 95 %. However, due to the large effect of ballast conditions in 'weight' carriers like cargo ships and tankers, calculations for these two ship types were made using a wider J range from 1.0 to 0.5 (increments of 0.1). When selecting values for J , consideration should be given to actual and planned loading conditions, bow and stern trim of the ship while sailing and other relevant factors. Table C-1 in Appendix C also lists some values of H_{kt} for comparison.

F.4.2 Detailed Design of ADC

In cases where the design ship can be designated, the value of H_{kt} and T_{FL} of that ship are used. However, in cases where it is not possible to designate the values of these parameters, the results of the statistical analysis described in Table F-1 can be applied. In the final analysis, a 'special investigation' for each individual site is justified due to the enormous costs of every additional metre of required ADC.

F.4.3 Comparison Ballast Draught with Appendix C

Tables C-1 and F-1 are based on different datasets. This section presents two examples for weight and volume carriers comparing ballasted draught T_B between these two tables that illustrates that they can be used to complement each other in the design process. The fully-loaded ballast windage W_{FL} is given by:

$$W_{FL} = W_B - (T_{FL} - T_B) \frac{(L_{pp} + L_{oa})}{2} \quad (\text{F-3})$$

where W_B is the ballasted windage, T_{FL} is the fully-loaded draught, L_{pp} and L_{oa} have been previously defined. Since L_{pp} is approximately 0.95 of L_{oa} , it is assumed that the average of L_{pp} and L_{oa} in Eq. (F-2) is equal to L_{oa} (actually 0.975 L_{oa}). Rearranging Eq. (F-1) for T_B gives:

$$T_B = T_{FL} - \frac{(W_B - W_{FL})}{L_{oa}} \quad (\text{F-4})$$

F.4.3.1 Oil tanker, 300,000 DWT

From Table C-1 for 300 000 DWT tanker: $L_{oa} = 350$ m, $T_{FL} = 21$ m, $W_{FL} = 5\,100$ m² and $W_B = 8,600$ m². Inserting these values into Eq. (F-3) gives:

$$T_B = T_{FL} - \frac{(W_B - W_{FL})}{L_{oa}} = 21 - \frac{(8\,600 - 5\,100)}{350} = 11\text{ m} \quad (\text{F-5})$$

From Table F-1: $T_{FL} = 24$ m, the air draught from the sea surface to the top of the ship $H_{st,F} = 45.6$ m for $J = 1.0$ for fully-loaded draught, and $H_{st,B} = 57.6$ m for $J = 0.5$ for ballasted draught. Since the height of the ship from the keel to the top H_{KT} is the same for a ship whether fully-loaded or ballasted, the value for T_B can also be estimated by:

$$T_B = T_{FL} - (H_{st,B} - H_{st,F}) = 24 - (57.6 - 45.6) = 12\text{ m} \quad (\text{F-6})$$

Thus, the estimated values of T_B are within 1 m of each other using data from Table C-1 or Table F-1. This is probably reasonable for design purposes.

F.4.3.2 Container ship, 100,000 DWT

From Table C-1 for 100,000 DWT container ship: $L_{oa} = 326$ m, $T_{FL} = 14.5$ m, $W_{FL} = 6,900$ m², and $W_B = 7,500$ m². Inserting these values into Eq. (F-3) gives:

$$T_B = T_{FL} - \frac{(W_B - W_{FL})}{L_{OA}} = 14.5 - \frac{(7\,500 - 6\,900)}{326} = 12.7 \text{ m} \quad (\text{F-7})$$

From Table F-1: $T_{FL} = 14.9 \text{ m}$, the air draught from the sea surface to the top of the ship $H_{st,F} = 50.6 \text{ m}$ for $J = 1.0$ for fully-loaded draught and $H_{st,B} = 53.5 \text{ m}$ for $J = 0.8$ for ballasted draught. We used a value of $J = 0.8$ for the ballasted draught on the container ship as this is a more realistic value for the ballasted condition of a 'volume' type of ship. The value for T_B can also be estimated by:

$$T_B = T_{FL} - (H_{st,B} - H_{st,F}) = 14.9 - (53.5 - 50.6) = 12 \text{ m} \quad (\text{F-8})$$

Thus, the estimated values of T_B are within 0.7 m of each other using data from Table C-1 or Table F-1. This is probably reasonable for design purposes.

Container Ship (m)

Coverage Rate	DWT	H_{kt}	T_{FL}	$H_{st} = H_{kt} - JT_{FL}$				
				J=1.0	J=0.95	J=0.9	J=0.85	J=0.8
95 %	10,000	45.4	8.3	37.1	37.6	38.0	38.4	38.8
	20,000	51.5	10.4	41.1	41.6	42.1	42.6	43.1
	30,000	55.0	11.9	43.1	43.7	44.3	44.9	45.5
	40,000	57.5	12.7	44.8	45.5	46.1	46.7	47.4
	50,000	59.4	13.2	46.3	46.9	47.6	48.2	48.9
	60,000	61.0	13.7	47.3	48.0	48.7	49.3	50.0
	100,000	65.4	14.9	50.6	51.3	52.1	52.8	53.5

Cargo Ship (m)

Coverage Rate	DWT	H_{kt}	T_{FL}	$H_{st} = H_{kt} - JT_{FL}$					
				J=1.0	J=0.9	J=0.8	J=0.7	J=0.6	J=0.5
95 %	1,000	25.4	4.4	21.0	21.4	21.9	22.3	22.7	23.2
	2,000	30.0	5.5	24.5	25.0	25.6	26.1	26.7	27.2
	3,000	32.6	6.3	26.3	27.0	27.6	28.2	28.9	29.5
	5,000	36.0	7.4	28.6	29.4	30.1	30.8	31.6	32.3
	10,000	40.6	9.3	31.3	32.2	33.2	34.1	35.0	35.9
	12,000	41.8	9.9	31.9	32.9	33.9	34.9	35.9	36.9
	18,000	44.5	11.3	33.2	34.3	35.4	36.6	37.7	38.8
	30,000	47.9	11.2	36.7	37.8	38.9	40.0	41.1	42.3
	40,000	49.8	12.3	37.5	38.7	39.9	41.2	42.4	43.6
	55,000	51.9	13.7	38.2	39.5	40.9	42.3	43.6	45.0
	70,000	53.5	14.8	38.7	40.1	41.6	43.1	44.6	46.1
	90,000	55.1	16.0	39.1	40.7	42.3	43.9	45.5	47.1
	120,000	57.0	17.6	39.4	41.2	42.9	44.7	46.5	48.2
	150,000	58.5	18.9	39.6	41.5	43.4	45.3	47.2	49.0

Table F-1: Air draught for container ship, cargo ship (includes bulk carrier), oil tanker, RoRo ship, PCC, LPG, LNG and passenger ship.

Note that $J = 1.0$ for fully-loaded condition with a low of $J = 0.5$ for weight carriers and $J = 0.8$ for volume carriers in ballast condition. [Takahashi, 2007 – Continued]

Oil Tanker (m)

Coverage Rate	DWT	H_{kt}	T_{FL}	$H_{st} = H_{kt} - JT_{FL}$					
				J=1.0	J=0.9	J=0.8	J=0.7	J=0.6	J=0.5
95 %	50,000	44.1	13.8	30.3	31.6	33.0	34.4	35.8	37.2
	70,000	48.9	13.8	35.1	36.4	37.8	39.2	40.6	42.0
	90,000	52.4	15.2	37.2	38.8	40.3	41.8	43.3	44.8
	100,000	53.9	15.8	38.1	39.7	41.3	42.9	44.5	46.0
	150,000	59.7	18.5	41.2	43.1	44.9	46.8	48.6	50.5
	300,000	69.6	24.0	45.6	48.0	50.4	52.8	55.2	57.6

Roll on/Roll-off (RoRo) Ship (m)

Coverage Rate	DWT	H_{kt}	T_{FL}	$H_{st} = H_{kt} - JT_{FL}$				
				J=1.0	J=0.95	J=0.9	J=0.85	J=0.8
95 %	3,000	36.3	5.9	30.4	30.7	31.0	31.3	31.6
	5,000	40.2	7.0	33.2	33.6	33.9	34.3	34.6
	10,000	45.5	8.8	36.7	37.1	37.6	38.0	38.4
	20,000	50.7	11.0	39.7	40.3	40.8	41.4	41.9
	40,000	56.0	9.9	46.1	46.6	47.1	47.6	48.1
	60,000	59.1	9.9	49.2	49.7	50.2	50.7	51.1

Pure Car Carrier(PCC) (m)

Coverage Rate	DWT	H_{kt}	T_{FL}	$H_{st} = H_{kt} - JT_{FL}$				
				J=1.0	J=0.95	J=0.9	J=0.85	J=0.8
95 %	3,000	33.5	5.5	28.0	28.3	28.5	28.8	29.1
	5,000	37.3	6.4	30.9	31.3	31.6	31.9	32.2
	12,000	44.0	8.1	35.9	36.3	36.7	37.1	37.5
	20,000	47.8	9.3	38.5	39.0	39.5	39.9	40.4
	30,000	50.9	10.4	40.5	41.0	41.5	42.1	42.6
	40,000	53.1	10.0	43.1	43.6	44.1	44.6	45.1
	60,000	56.2	11.2	45.0	45.5	46.1	46.6	47.2

Table F-1: Air draught for container ship, cargo ship (includes bulk carrier), oil tanker, RoRo ship, PCC, LPG, LNG and passenger ship.

Note that $J = 1.0$ for fully-loaded condition with a low of $J = 0.5$ for weight carriers and $J = 0.8$ for volume carriers in ballast condition. [Takahashi, 2007 – Continued]

LPG Ship (m)

Coverage Rate	DWT	H_{kt}	T_{FL}	$H_{st} = H_{kt} - JT_{FL}$				
				J=1.0	J=0.95	J=0.9	J=0.85	J=0.8
95 %	3,000	33.3	7.3	26.0	26.4	26.7	27.1	27.5
	5,000	37.0	8.4	28.6	29.0	29.4	29.8	30.2
	10,000	41.9	10.3	31.6	32.1	32.6	33.2	33.7
	20,000	46.9	12.5	34.4	35.0	35.6	36.2	36.9
	30,000	49.8	14.0	35.8	36.5	37.2	37.9	38.6
	40,000	51.8	15.2	36.6	37.4	38.1	38.9	39.7
	60,000	53.4	16.2	37.2	38.0	38.8	39.6	40.5

LNG Ship (m)

Coverage Rate	DWT	H_{kt}	T_{FL}	$H_{st} = H_{kt} - JT_{FL}$				
				J=1.0	J=0.95	J=0.9	J=0.85	J=0.8
95 %	80,000	64.5	12.3	52.2	52.8	53.5	54.1	54.7
	100,000	71.5	13.0	58.5	59.1	59.8	60.4	61.1
	120,000	77.1	13.5	63.6	64.3	65.0	65.7	66.3

Passenger Ship (m)

Coverage Rate	DWT	H_{kt}	T_{FL}	$H_{st} = H_{kt} - JT_{FL}$				
				J=1.0	J=0.95	J=0.9	J=0.85	J=0.8
95 %	3,000	38.5	6.1	32.4	32.7	33.0	33.3	33.6
	5,000	43.0	7.2	35.8	36.1	36.5	36.9	37.2
	10,000	49.1	9.1	40.0	40.5	40.9	41.4	41.8
	20,000	55.2	8.9	46.3	46.8	47.2	47.7	48.1
	30,000	58.8	8.9	49.9	50.4	50.8	51.3	51.7
	50,000	63.4	8.9	54.5	54.9	55.3	55.8	56.2
	70,000	66.3	8.3	58.0	58.4	58.9	59.3	59.7
	100,000	69.5	8.3	61.2	61.6	62.0	62.4	62.8

Table F-1: Air draught for container ship, cargo ship (includes bulk carrier), oil tanker, RoRo ship, PCC, LPG, LNG and passenger ship.

Note that $J = 1.0$ for fully-loaded condition with a low of $J = 0.5$ for weight carriers and $J = 0.8$ for volume carriers in ballast condition. [Takahashi, 2007 – Concluded]

12 APPENDIX G: SPANISH AND JAPANESE METHODS FOR DESIGN OF CHANNEL WIDTH

This appendix contains introductions to standards for concept and detailed design of channel width in Spain and Japan:

(a) “G1 Spanish Recommendation for Maritime Works”. ROM 3.1.99 (English and Spanish versions) can be downloaded from:

http://www.puertos.es/programa_rom/cual_es/index.html

(b) “G2 Japanese Design Method” and

(c) “G3 Detailed Japanese Formulae on Wind-Wave-Current Effects versus Ship Type-Sizes”. This section provides details of the theory used in the Japanese Concept Design Excel spreadsheet program *J-Fairway* that can be downloaded from:

<http://www.y.sk.nilim.go.jp/kakubu/kouwan/keikaku/J-Fairway-e.html>

It was developed by Japan Institute of Navigation, Standard Committee and Japan Ministry of Land, Infrastructure, Transportation and Tourism (MLIT), National Institute for Land and Infrastructure Management (NILIM).

It should be remarked that the drafters of the Spanish method ((ROM 3.1-99) and Japanese method (Japan Institute of Navigation, Standard committee) are responsible for these design methods. They are included here as a convenience for the readers of this report. More detailed explanations can be found in the original documents. In this appendix the word ‘fairway’ is used synonymously with the word ‘channel’ in the main WG 49 report.

13 G1: SPANISH RECOMMENDATIONS FOR CONCEPT DESIGN WIDTH

G1.1 General Design Criteria

G1.1.1 Design Lifetime

The design lifetime of a Navigation Channel or a Harbour Basin is defined as the period of time elapsing from the beginning of its construction to its decommissioning, abandonment or change of use.

Type of work	Safety level required		
	Level 1	Level 2	Level 3
General infrastructure	25 (15)	50 (25)	100 (40)
Specific industrial infrastructure	15 (10)	25 (15)	50 (25)
Note: The figures in brackets may be used when plan and elevation reserve spaces that do not form practically inalterable physical restrictions are maintained, taking such to be those which force structures delimiting their boundaries to be demolished.			

Table G1-1: Minimum useful lifetimes for definitive navigation channels or harbour basins (in years)

Legend for Table G1-1:

GENERAL INFRASTRUCTURE:

- General Navigation Channels or Harbour Basins, not linked to the exploitation of an industrial facility or a single specific terminal.

SPECIFIC INDUSTRIAL:

- Navigation Channels or Harbour Basins in the service of an industrial facility or of a single specific terminal or linked to the exploitation of resources or deposits of a transitory nature (for instance, the service port for an industry, ore loader attached to a specific deposit, oil rig, etc.).

LEVEL 1:

- Navigation Channels or Harbour Basins in local interest or auxiliary facilities.
- Low risk of losses of human lives or environmental damage in the event of an accident. (Minor ports with no traffic of vessels carrying polluting, flammable or hazardous products, marinas, auxiliary ports for work construction equipment or for boats not having to operate under conditions worse than those of the auxiliary port's design, etc.).

LEVEL 2:

- Navigation Channels or Harbour Basins in general interest facilities.
- Moderate risk of losses of human lives or environmental damage in the event of an accident. (Large ports with no traffic involving polluting, flammable or hazardous products, or minor ports which, should they have this traffic, keep to the safety distances from urban centres or areas of a high environmental value

specified by their particular regulations, etc., in all navigation channels and harbour basins accessible to them).

LEVEL 3:

- Navigation Channels or Harbour Basins in ports and facilities of a supranational nature.
- High risk of losses of human lives or environmental damage in the event of an accident. (Large ports with traffic involving polluting, flammable or hazardous products and the highest values of Useful Lifetime must be adopted if the Navigation Channels or Harbour Basins located in urban areas or areas of a high environmental value, etc.).

G1.1.2 Elements Defining a Navigation Channel and Harbour Basin

A correct definition of a Navigation Channel or a Harbour Basin requires the following elements to be determined:

- The geometric configuration of the water and above water space used, by means of the necessary layout and elevation definitions of the axes, alignments, curves, heights, levels and whatever elements may be necessary for an unequivocal determination of such spaces.
- Navigation marking planned to be installed for in situ identification of such spaces, the definition of which shall be especially concrete in the case whereby the design has been refined based on the accuracy of certain navigation aids.
- Maritime and atmospheric limit conditions which will allow Navigation Channels or Harbour Basins to be used under Normal Operating Conditions. These conditions may be different according to the vessel type and dimensions, the tugs available or as a function of any other particular condition defined in each case.
- Necessary basic towing requirements for certain types of vessel to use Navigation Channels and Harbour Basins, associated to the environmental conditions in which these manoeuvres may be performed under Normal Operating Conditions.

A Navigation Channel or a Harbour Basin is not therefore defined only by its geometric characteristics and navigation marking but also by its operational conditions and by the need to use or not to use tugs or other navigation aids. These are circumstances which determine not just the fact of being able to avail of greater or lesser percentages of time suitable for vessel operation but also the actual dimensions of the required water spaces.

G1.1.3 Design Criteria

The fundamental criterion for defining and dimensioning elements forming a Navigation Channel or a Harbour Basin is safety in manoeuvring and operations carried out in them. To this end, regardless of the general safety criteria as specified in Table G2.1, the risk/safety criteria recommended in keeping with the circumstances and characteristics of each case, are as follows:

1. Geometric dimensions assessment criteria

The geometric definition of Navigation Channels or Harbour Basins is based on knowing the spaces occupied by vessels, which depend on:

- The vessel and the factors affecting its movements.
- The water level and factors affecting its variability.

For navigation to occur under safe conditions, the spaces occupied by the vessel must have sufficient room within the physical spaces available at the site, for which factors of uncertainty related to the boundaries (seabed, parameters, other vessels navigating or floating, elements affecting above water clearances, etc.) must be taken into account.

Additional spaces must be provided between those required by vessels and those available according to the site's boundary conditions, with the purpose of keeping a suitable safety margin. They are entered to take into account, amongst others, those factors which cannot be suitably modelled in the calculation processes, the degree of statistical reliability of the design data, the uncertainty in methods for determining the vessel's behaviour, etc.

Safety factors in other design Standards and Recommendations are therefore, here, Safety Margins or Clearances and are thus additional spaces which are to be added to those required by vessels, to verify that these spaces, the sum of both, fit into the spaces available at the site. The equation for verifying the safety requirements for the dimensions of a Navigation Channel or a Harbour Basin is expressed by:

$$X_e \geq X_b + X_s \quad (G1-0)$$

where:

X_e = Space available at the site

X_b = *Space occupied by the vessel*

X_s = *Safety Clearance.*

The characteristic values of the dimensions defining the space occupied by vessels will be determined from statistical data, as far as possible, adopting the value associated to the acceptable risk level (E), which is defined as the probability of at least one incident occurring (contact, running aground, impact or collision as described in point 2.5.4) of at least one vessel during the useful lifetime of the design phase being analysed (Lf).

The maximum risks acceptable for the Service Phase are shown in Table G1-2. The same acceptable risks will be adopted for the Construction Phase unless smaller values are justified.

The maximum acceptable risk will be the initial damage risk or total loss risk considering the importance of the damage to the vessel or vessels affected and the effect this damage may have on the operation of the area being analysed or on other areas affected by it.

Should the foreseeable damage for vessels not affect their seaworthiness significantly or when the consequences of the incident do not lead to interrupting the area's general maritime traffic for periods above 2 days in the case of supranational ports or facilities, 5 days in the case of ports and facilities of a general interest and 10 days in the remaining cases, initial damage risk values may be adopted. Values for the total loss risk will be adopted in the remaining cases.

Risk of damage		Possibility of loss of human lives	
		Reduced	Expected
Economic repercussion in the case of an incident (ELU) Index = $\frac{\text{Cost of losses}}{\text{investment}}$	LOW	0.50	0.30
	MEDIUM	0.30	0.20
	HIGH	0.25	0.15

Total loss risk		Possibility of loss of human lives	
		Reduced	Expected
Economic repercussion in the case of an incident (ELU) Index = $\frac{\text{Cost of losses}}{\text{investment}}$	LOW	0.20	0.15
	MEDIUM	0.15	0.10
	HIGH	0.10	0.05

Table G1-2: Maximum acceptable risks

Legend for Table G1-2:

POSSIBILITY OF LOSS OF HUMAN LIVES

- Reduced: When loss of human lives in an accident is not expected.
- Expected: When the loss of human lives in an accident is expected.

ECONOMIC REPERCUSSION IN THE EVENT OF AN INCIDENT

Index re = Cost of direct and indirect losses/Investment

- LOW: $re \leq 5$
- MEDIUM: $5 < re \leq 20$
- HIGH: $re > 20$

2. Accidental cases assessment

Accidental cases are taken to be those events of a fortuitous or abnormal nature which do not stem from mere difficulties of handling a vessel under Normal Operating Conditions. A vessel's engine or rudder failures, faults in tug operations, mooring line breakages, etc. may be quoted amongst them.

They may be considered as cases varying in nature with low probability of occurring or that manifest for a short time throughout the Useful Lifetime of the area being considered but which, if occurring, have an effect that may bear heavily on safety.

Although these accidental cases should not be the basis for dimensioning the elements of Navigation Channels and Harbour Basins, it is advisable to address the circumstances of these cases, taking into consideration that Safety Margins in these cases may be reduced or eliminated according to the assessment made of the accident's consequences in each case.

G1.2 Horizontal Dimensioning of Channels and Harbour Basins

G1.2.1 Introduction

The layout configuration and dimensions necessary in different Navigation Channels and Harbour Basins will be determined in each case taking the following factors into account:

- The size, dimensions and manoeuvrability characteristics of vessels and vessel related factors, including the availability of tugs on which the surface area required for vessel navigation, manoeuvring or staying in the area under consideration (B1) depends. The safety margins are also included in this block (B1). Safety margins are established to prevent a vessel colliding with Navigation Channels or Harbour Basin boundaries or other ships or fixed or floating objects which may exist in the surroundings.
- Aids to navigation available and factors affecting their accuracy and reliability, which will determine the reference lines or points for positioning the vessel (B2).
- Factors related to the contour channel (B3).

Taking the foregoing (B1) and (B2) factors into account will quantify the minimum layout area and dimensions, or nominal dimensions that must be required of the nominal water depths if the use of water areas is analysed or in above water clearances if dealing with the sweeping of such areas, both calculated (nominal depth and clearance) with the criteria as given in Section 1.3. These horizontal nominal areas will require the boundary related factors (B3) to be taken into account in order to be guaranteed as areas available at the site which section 1.2.3 specifies.

Apart from these factors, which are specific to vessel navigation and floatation, other conditioning factors alien to this function which may prove to be determining factors for the design of the Area under analysis must be taken into account in each case.

G1.2.2 General Criteria

There is no integral analysis model currently available which takes all factors into account, and this is why Navigation Channels or Anchorage layout design has usually been performed by some of the following procedures:

- Totally empirical methods setting dimensions as a function of good engineering practice criteria.
- Semi-empirical methods combining a mathematical analysis of some of the factors with the empirical consideration of the remainder.
- Computer model simulation with human pilots or using automatic pilots, in combination with a statistical analysis of the results obtained.

This Recommendation, lays down two procedures: deterministic and semi-probabilistic, of which the former is semi-empirical and the latter is based on using human pilot simulation models and both enable design to be associated to the established operating conditions and to the risk accepted for the design. In both cases, Safety Margin (B_3) is empirically determined.

Section 9 of the ROM analyses the use of simulation models and recommendations are given on the advisability of using these types of study which, in general, will be most necessary in the following cases:

- When maritime or meteorological environmental conditions vary in the Area.
- When manoeuvres are undertaken with manual pilots and area availability does not enable the solutions as recommended to be developed by deterministic methods.
- When it is wished to optimise the design by deterministic methods, taking the design as comprising the elements defined in section G1.1.2. (geometric configuration, marking and navigation marking systems, limit environmental operating conditions and tug availability).
- When finding consensus solutions or for training operators who will be intervening in navigation or manoeuvres.

G1.2.3 General Layout Recommendations

Although the plan alignment of fairways largely depends on local conditions, the following general recommendations to be taken into account in the design may be made:

- A fairway should be as straight lined as possible, avoiding S alignments (bend followed by a reverse bend).
- If feasible, a fairway shall follow the direction of the main currents, so that the cross-current effect is minimised. This criterion shall also be followed with winds and waves although this will be more difficult to achieve as they usually arrive from different directions.
- A fairway must avoid areas of sediment accretion or deposit to minimise maintenance costs.
- If feasible, approach fairways will be oriented so that storms on the abeam are avoided, i.e. preferably orienting them in the prevailing wave direction or at most forming an angle of up to 15/20° between the fairway's axis and the direction of these prevailing waves.
- Harbour entrance approach fairways must preferably be straight, avoiding bends in or close to the entrance so that the need for vessels to alter course in a difficult, critical navigation area is avoided. If bends were imperative, they will be located, if possible, so that the fairway fulfils the conditions recommended for passing narrow sections.
- Fairway alignments will endeavour to avoid vessels having to make their approach to quays or berths beam on, as this might cause an accident should control over the vessel be lost. If possible, a fairway should be located parallel to quays and berths so that such manoeuvre can be performed with a minimum of risk. Extreme care will be taken with respect to this precaution in the case of hazardous cargo traffic.
- Narrow sections (bridges, entrances, etc.) will be passed in well navigation marked, straight fairway stretches, keeping the alignment straight over a minimum distance of 5 lengths (L) of the maximum vessel, on either side of the narrow section.
- Should bends be necessary, a single bend is better than a sequence of small bends at short intervals provided the fairway is correctly navigation marked.

- The bend radius will be a minimum of 5 lengths (L) of the largest vessel it is envisaged will be using the fairway, but preferably using radii of 10 lengths (L) or more if feasible; the higher values will be used the larger the angle between the straight alignments defining the bend.
- The length of curved legs must not be greater than half the bend's radius, which means that the angle between straight alignments must not be greater than 30° , if feasible.
- Straight legs located between bends must have a length 10 times the length (L) of the largest vessel expected to be using the fairway, if viable.
- Visibility measured on the fairway's axis must be greater than the design vessel's stopping distance, assuming it is navigating at the maximum navigating speed admissible in the fairway.
- Transitions between stretches of a different width will be made by adjusting the limit or limitation lines by means of straight alignments with ground plan variations not greater than 1:10 (preferably 1:20) in each one.

G1.2.4 Fairway Width

G1.2.4.1 General Criteria

A fairway's width, measured perpendicular to its longitudinal axis will be determined by the sum of the following terms:

$$B_t = B_n + B_r \quad (G1-0)$$

where:

B_t = The fairway's overall width.

B_n = The fairway's nominal width or clear space which must remain permanently available for vessel navigation, including Safety Margins. This nominal width therefore includes the influence of all factors designated as B_1 and B_2 in section 1.2.1.

B_r = An additional reserve width for taking into account boundary related factors (B_3). (For instance, reserve for slope instability in the case of the fairway's boundaries being made with this type of structure). This width may be different on either bank, B_{ri} or B_{rd} , according to the latter's nature and characteristics.

The overall width B_t will be measured at the narrowest point of the fairway's cross-section, which, being areas of water, will usually coincide with the width between slopes or structures of the fairway's banks measured at the fairway's nominal depth for the design vessel.

Should quays or berths or any other type of facility be built on the fairway's banks, the spaces required for their implementation and operation with the safety margins as established will be located outside the fairway's overall width B_t . In the absence of specific criteria, a reserve of area 2.5 times the design vessel's beam will be kept between the channel's limit and any vessel which might be berthed at adjacent quays. This $2.5B$ reserve space will be likewise kept between the channel's limit and the most advanced position a vessel anchored or moored in its vicinity may reach.

The nominal fairway width B_n will be calculated in accordance with the following criteria, depending on whether the deterministic or the semi-probabilistic method is used.

G1.2.4.2 Determining Nominal Width B_n by the Deterministic Method

Single Lane Fairways

1. Navigation in straight stretches under constant environmental conditions over the whole track

The minimum nominal width of a straight stretch, single lane fairway (thus with no possibility of vessel passing or overtaking manoeuvres) should the maritime and meteorological environmental conditions (winds, waves and currents) be constant over the whole track, will be determined as the sum of the following dimensions (see Figure G1-1):

$$B_n = B + b_d + 2(b_e + b_r + b_b) + (rh_{sm} + rh_{sd})_i + (rh_{sm} + rh_{sd})_d \quad (G1-0)$$

where:

B = Maximum beam of vessels which will sail over the fairway.

b_d = Additional width of the vessel's swept path produced by navigation with a certain angle (drift angle) to the fairway's axis, in order to correct the vessel's drift caused by the wind, wave, current or tug effect. The additional width necessary (b_d) will be calculated with the following formula:

$$b_d = L_{pp} \cdot \sin \beta \quad (\text{for evaluating water spaces})$$

$$b_d = L_{oa} \cdot \sin \beta \quad (\text{for evaluating above water spaces})$$

where:

L_{pp} = Length between the design vessel's perpendiculars.

L_{oa} = Design vessel's length overall.

β = Angle of drift, which can be determined with the following formulas valid for values of $\beta \leq 25^\circ$.

Drift caused only by wind action (also called cast in this case)

$$\beta = \arcsin \frac{K_v \cdot C_v \cdot V_{sr} \cdot \sin \alpha_{vr}}{V_r} \quad (G1-0)$$

where:

K_v = Coefficient depending on the hull's shape, the ratio h/T between the site's water depth (h) and the vessel's draught (T) and the angle α_{vr} . For conventional and bulbous bow hulls, the coefficient K_v may be obtained by linearly interpolating between the values given in the table below:

h/T	K_v			
	$\alpha_{vr} \leq 10^\circ$	$\alpha_{vr} = 30^\circ$	$\alpha_{vr} = 60^\circ$	$\alpha_{vr} = 90^\circ$
Conventional hulls				
≤ 1.20	0.0243	0.0161	0.0130	0.0121
2.00	0.0255	0.0168	0.0136	0.0127
≥ 5.00	0.0259	0.0171	0.0139	0.0129
Bulbous bow hulls				
≤ 1.20	0.0343	0.0227	0.0184	0.0172
2.00	0.0402	0.0266	0.0216	0.0201
≥ 5.00	0.0423	0.0280	0.0227	0.0211

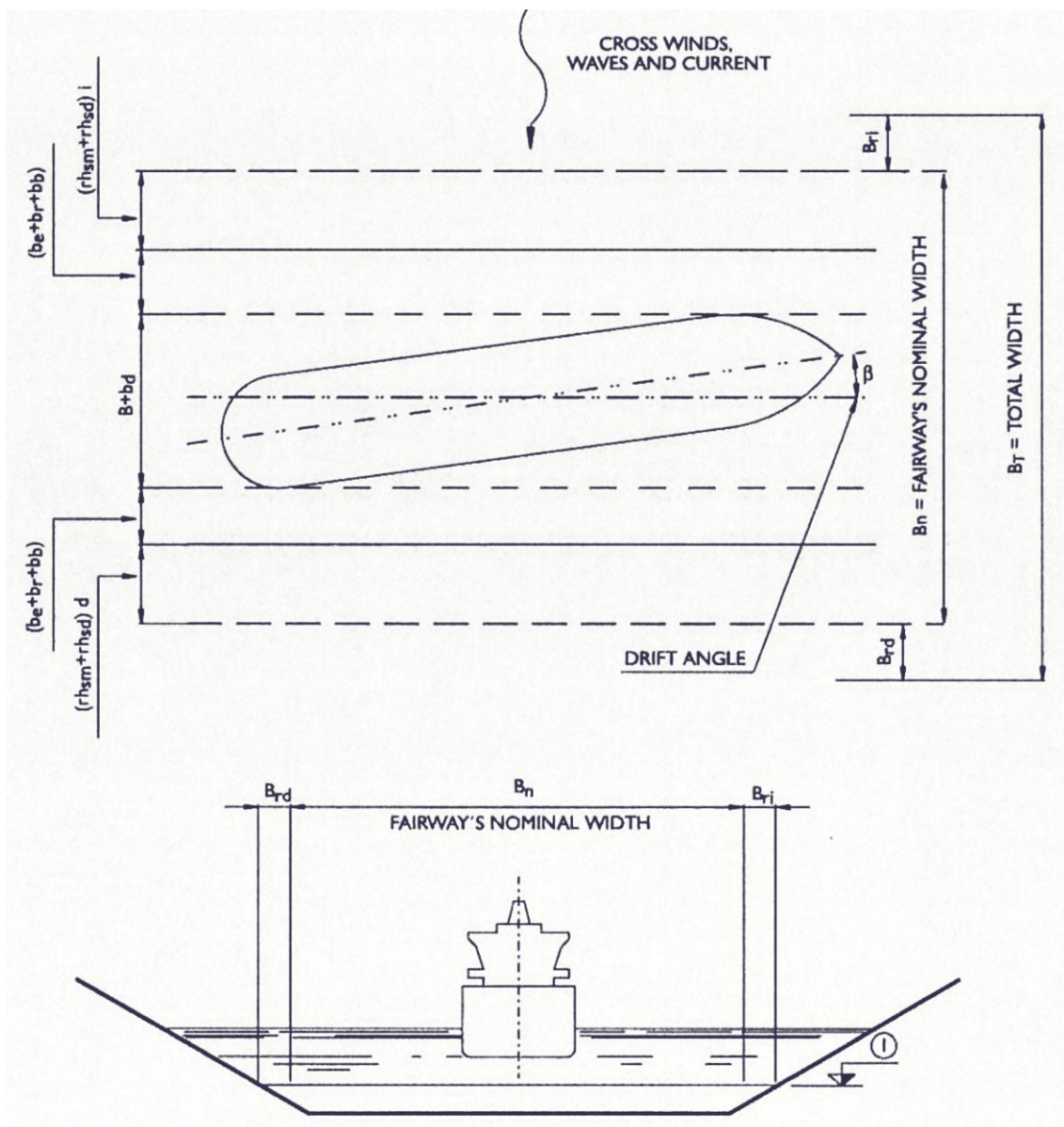

(l) Fairway's nominal depth

Figure G1-1: Width of straight stretch fairways with a single navigation line

$$C_v = \left(\frac{A_{LV}}{A_{LC}} \right)^{0.5} \quad (G1-0)$$

A_{LV} = Windage of the vessel's longitudinal projection.

A_{LC} = Vessel's longitudinal submerged area projected onto the centre line plane.

V_{vr} = Wind speed relative to the vessel being analysed. The absolute wind speed values considered as the fairway's operating limit will be used to determine same.

V_r = Vessel's speed relative to the water. This relative speed takes into account the presence of fluvial currents, tidal currents, etc.

α_{vr} = Angle between the relative wind direction (incoming) and the vessel's centre line plane.

Drift caused only by current action

$$\beta = \arctg \frac{V_c \cdot \sin \alpha_{cv}}{V + V_c \cdot \cos \alpha_{cv}} \quad (G1-0)$$

where:

V_c = Absolute current speed considered as the fairway's operating limit.

V = Vessel's speed relative to the seabed or absolute vessel speed. Note that this speed is different than V_r defined above. In the absence of specific criteria, V can be estimated within the margins listed in the table below. Use the lowest values of V in the formulas in this Section G1.2.4.

α_{cv} = Angle between the absolute current direction (incoming) and the vessel's absolute speed.

Channel Description	Absolute speed V	
	m/s	knots
Outer areas		
• Approach lanes		
Long ($\geq 50 L_{pp}$)	4-7.5	8-15
Short ($< 50 L_{pp}$)	4-6	8-12
• Anchorage	1-1.5	2-3
• Main Channel	3-5	6-10
• Manoeuvring Area	2-3	4-6
• Berth (jetty) Area	1-1.5	2-3
• Passing entrances	2-4	4-8
Inner areas		
• Anchorage	1-1.5	2-3
• Channel	3-5	6-10
• Manoeuvring Area	2-3	4-6
• Basin dock and berths	1-1.5	2-3

Drift caused only by wave action

$$\beta = \arcsin \left[K_w \cdot \left(\frac{g}{T} \right)^{0.5} \cdot \frac{H_s}{V_r} \right] \quad (G1-0)$$

where:

K_w = Coefficient depending on the hull's shape, on the ratio h/T between the site's water depth (h) and the vessel's draught (T) and the angle α_w . (It is assumed in a first approximation that this coefficient is irrespective of the wave period and length. For conventional and bulbous bow hulls, the coefficient K_w may be obtained by linearly interpolating between the values in the table below:

h/T	K_w						
	$\alpha_w \leq 10^\circ$	$\alpha_w = 30^\circ$	$\alpha_w = 60^\circ$	$\alpha_w = 90^\circ$	$\alpha_w = 120^\circ$	$\alpha_w = 150^\circ$	$\alpha_w \geq 170^\circ$
Conventional hulls							
≤ 1.20	0.0296	0.0512	0.1067	0.1323	0.1183	0.0725	0.0418
2.00	0.0310	0.0537	0.1118	0.1387	0.1240	0.0760	0.0439
≥ 5.00	0.0315	0.0546	0.1137	0.1410	0.1261	0.0772	0.0446
Bulbous bow hulls							
≤ 1.20	0.0418	0.0725	0.1508	0.1871	0.1673	0.1025	0.0592
2.00	0.0490	0.0849	0.1768	0.2193	0.1961	0.1201	0.0693
≥ 5.00	0.0515	0.0892	0.1857	0.2303	0.2060	0.1261	0.0728

α_w = Angle between the wave propagation direction (incoming) and the vessel's centre line plane.

g = Acceleration of gravity

H_s = Significant wave height of the waves considered as the fairway operating limit for the vessel being analysed.

T = Draught of the vessel under analysis.

Drift caused only by tug action

$$\beta = \arcsin \left[K_r \left(\frac{g \cdot F_{TR}}{A_{LC} \cdot \gamma_w} \right)^{0.5} \frac{1.0}{V_r} \right] \quad (G1-0)$$

where:

K_r = Coefficient depending on the hull's shape, on the ratio h/T between the site's water depth (h) and the vessel's draught (T). It may be obtained by interpolating between the following values in the table below:

h/T	K_r	
	Bulbous bow	Conventional bow
≤ 1.20	0.63	0.45
2.00	0.74	0.47
≥ 5.00	0.78	0.48

g = Acceleration of gravity

F_{TR} = Component of the force resulting in the vessel's transverse direction from tugs acting on it.

A_{LC} = Vessel's submerged longitudinal area projected onto the centre line plane.

γ_w = Specific weight of water.

Drift caused by simultaneous action of wind, currents, waves and tugs

The drift angle β will be calculated assuming that its sine is the sum of the sines of the drift angles for the different forces acting separately:

$$\sin \beta = (\sin \beta)_{\text{wind}} + (\sin \beta)_{\text{currents}} + (\sin \beta)_{\text{waves}} + (\sin \beta)_{\text{tugs}} \quad (G1-0)$$

This sum will be algebraic and, therefore, each drift will be considered with its pertinent plus or minus sign. It must be pointed out in this respect that drift for each effect occurs in the direction taking the bow towards the side where the action is received.

The limit navigation conditions are recommended to be selected so that drift angles above the following do not occur, in the event the vessel is sailing at the lowest transit speeds admissible.

Description	β (deg)
Fairways in areas with $h/T \geq 1.20$	
• Normal stretches	5
• Singular points	10
Fairways in areas with $h/T = 1.50$	
• Normal stretches	10
• Singular points	15
Fairways in areas with $h/T \geq 5.00$	
• Normal stretches	15
• Singular points	20

where (h) is the at-rest or static water depth (ignoring effects of trim) and (T) is the vessel's draught.

$b_e =$ Additional width through positioning errors. This relates to the difference (only the component crosswise to the fairway's axis) between the vessel's true position and the position as estimated by the captain using the information methods and aids to navigation available in the Navigation or Floatation Area being analysed. The following will be used in the absence of further information on the accuracy of these aid systems. All values for electronic systems are for 95 % predictable accuracy.

Type of Positioning	No experienced pilot/captain	Experienced pilot/captain
Visual Positioning		
Open estuaries, without navigation marking	100 m	50 m
Buoys or beacons in approach ways	50 m	25 m
Visual positioning between buoy or beacon alignments marking fairway limits	20 m	10 m
Leading lines	0.5°	0.5°
Radio electric systems (valid for locating on a nautical chart with no visual positioning)		
• Radio beacons	5.0°	5.0°
• Radar (aboard), S Band	1.5°	1.5°
• Radar (aboard), X Band	1.0°	1.0°
• RACON (distance/delay)	150 m/0.3°	150 m/0.3°
• TRANSIT Dual Frequency	25 m	25 m
GPS	100 m	100 m
DGPS	10 m	10 m

Notes for table:

The difference in position in all the values expressed in degrees is the product of the distance multiplied by the sine of the pertinent angle and will not always coincide with the component transversal to the fairway's axis which is the value b_e sought.

Should the fairway be dimensioned assuming operation with pilot or experienced captain, this condition shall be shown in the pertinent Operating Rules or Manuals.

Should the characteristics of the aid to navigation system not be known, a value equal to the maximum beam B of vessels operating in the fairway will be taken as the measurement of this additional width b_e for preliminary studies.

b_r = Additional response width which assesses the additional deviation that may occur from the moment when the vessel's deviation from its theoretical position is detected and the instant when the correction becomes effective. This additional width will be determined as a function of the vessel's manoeuvrability characteristics, of the maximum beam (B), of the ratio between the site's at rest water depth (h) and the vessel's draught (T) and of the Maximum Admissible Risk (E_{max}) during the Useful Life of the Design Phase being analysed, by means of the expression:

$$b_r = (1.50 - E_{max}) b_{ro} \quad (G1-0)$$

where:

E_{max} = Maximum Admissible Risk determined with the criteria as given in Table G1-2.

b_{ro} = Additional response width for a value of $E_{max} = 0.50$, which can be determined with the following criteria:

Vessel's manoeuvrability	b_{ro}	
	$h/T \leq 1.20$	$h/T \geq 1.50$
Good	0.10 B	0.10 B
Medium	0.20 B	0.15 B
Bad	0.30 B	0.20 B

where:

- *Good manoeuvring capability vessels*: Warships (except submarines), ferry and RoRo vessels, small boats (fishing and pleasure). Vessels in the following paragraph could also be considered as having a good manoeuvring capability if their cargo status is less than 50 %.
- *Medium manoeuvring capability vessels*: Oil tankers, bulk carriers, methane carriers, liquid gas carriers, container ships, general cargo merchant ships, multipurpose carriers and passenger vessels, with cargo statuses equal to or greater than 50 %.
- *Bad manoeuvring capability vessels*: disabled and badly maintained old vessels.

Medium vessel manoeuvrability conditions will be used for dimensioning general traffic fairways since, in general, bad manoeuvrability will relate to old ships which will not usually be the largest dimensioned or to disabled vessels whose transit through the fairway may be regulated with special aids to navigation so that risks are reduced.

b_b = Additional width for covering an error which might derive from the navigation marking systems. In the absence of greater information on the characteristics of these systems, the following criteria will be used:

- The maximum swing which a buoy may display in relation to its theoretical position will be calculated for buoy marking under the Limit Environmental Operating Conditions and under extreme tidal conditions which might occur. The possibility of buoy dead man anchors (sinkers) dragging will also be considered in the case whereby environmental or channel maintenance conditions do not guarantee the sinkers will remain in their theoretical anchoring position.
- Optical leading line instrument errors: 0.5° . The difference in position caused by this error is the product of the distance multiplied by the sine of the angle and, therefore, it will be necessary in each case to calculate the one transversal to the fairway's axis, which is the value b_b sought.

rh_{sm} = Additional safety clearance which should be considered on each side of the fairway to enable the vessel to navigate without being affected by bank suction or rejection effects. This clearance may be different on either bank, $(rh_{sm})_i$ (i.e. left margin) and $(rh_{sm})_d$ (i.e. right margin), depending on their nature and will be determined as per the following criteria in which it has been assumed that the Safety Margin (rh_{sd}) specified in the following paragraph always exists. This is why values of $rh_{sm} + rh_{sd}$ lower than those indicated here cannot be accepted in any event:

Description	rh_{sm}	rh_{sd}	$rh_{sm}+rh_{sd}$
Fairways with sloping channel edge and shoals ($V/H \leq 1/3$)			
• Vessel's absolute speed ≥ 6 m/s	$0.6 B$	$0.1 B$	$0.7 B$
• Vessel's absolute speed between 4 and 6 m/s	$0.4 B$	$0.1 B$	$0.5 B$
• Vessel's absolute speed ≤ 4 m/s	$0.2 B$	$0.1 B$	$0.3 B$
Fairways with rigid slopes ($V/H \geq 1/2$) or with rocky or structural banks			
• Vessel's absolute speed ≥ 6 m/s	$1.2 B$	$0.2 B$	$1.4 B$
• Vessel's absolute speed between 4 and 6 m/s	$0.8 B$	$0.2 B$	$1.0 B$
• Vessel's absolute speed ≤ 4 m/s	$0.4 B$	$0.2 B$	$0.6 B$

where (B) is the vessel's maximum beam and (V/H) the bank slope gradient calculated by the ratio between the vertical and horizontal projection of a unit of length measured on the slope.

rh_{sd} = Safety Margin or unhindered horizontal clearance which must always be available between the vessel and the fairway's banks, slopes or boundaries. It will be determined from the values given in the foregoing paragraph which tend to minimize the risk of the vessel making contact, in keeping with the nature of the fairway's banks. This clearance may be different on each bank $(rh_{sd})_i$ $(rh_{sd})_d$ according to their nature and characteristics.

2. Navigation in straight stretches with environmental conditions varying over the track

Should environmental conditions vary in short stretches along the fairway's axis, which frequently occurs in harbour entrances, where channels meet, changes of fairway alignment not matching the current flow and in other similar cases, vessel navigability conditions must be adjusted to this varying system by modifying their angle of drift to different, even opposing values, which produces curvilinear or zigzag paths with a larger occupied area of the path being swept by the vessel. The path and greater larger path swept by the vessel can only be accurately determined by means of physical models, complex mathematical models or by simulation studies. The additional width necessary for these manoeuvres may be approximately estimated by assuming that drift caused by the unbalanced cross forces increasing the width of the swept path followed by the vessel

in the time in which the ship moves from one balance status to another. Under this assumption, the waterway's nominal width in the varying stretch will be determined by applying the criteria expounded in paragraph 1 of this section, increasing the additional width b_d of the vessel's swept path by an additional amount b_{dv} determined by the expression:

$$b_{dv} = V_{rr} t_c (\sin\beta_0 - \sin\beta_1) \quad (G1-0)$$

where:

b_{dv} = Additional width of the vessel swept path caused by the varying environmental conditions.

V_{rr} = Vessel's speed relative to the current speed in the fairway in the same direction as the ship's heading.

t_c = Time necessary to correct the vessel's manoeuvre, determined with the following criteria:

Manoeuvrability	No experienced pilot/captain	Experienced pilot/captain
Good		
• Fishing and pleasure	120 s	60 s
• Other types of vessel	135 s	75 s
Medium	150 s	90 s
Bad	180 s	120 s

Medium vessel manoeuvrability conditions will be used for dimensioning general traffic fairways since, in general, bad manoeuvrability will relate to old ships which will not usually be those with the greatest dimensions or to disabled vessels whose transit through the fairway may be regulated with special aids to navigation so that risks are reduced.

Should the fairway be dimensioned assuming operation with pilot or experienced captain, this condition shall be shown in the pertinent Operating Rules or Manuals.

β_0 = Maximum drift angle in the environmental condition varying area.

β_1 = Drift angle on the navigation stretch before (β_{1a}) or after (β_{1p}) the area of environmental condition variation. The algebraic value will be taken in relation to β_0 , i.e. with a minus sign should the drift angle have a contrary sign.

In most cases, determining the additional width will require checks to be made for navigation in both directions, and two alterations to course in each one will be analysed:

- That occurring between the permanent prior navigation area and the varying environmental condition area.
- That occurring between the varying environmental condition area and the rear permanent navigation area.

Figure G1-2 shows the most frequent navigation cases for:

- Localised worsening of transversal environmental conditions.
- Localised improvement in transversal environmental conditions
- Change in direction of transversal environmental conditions.

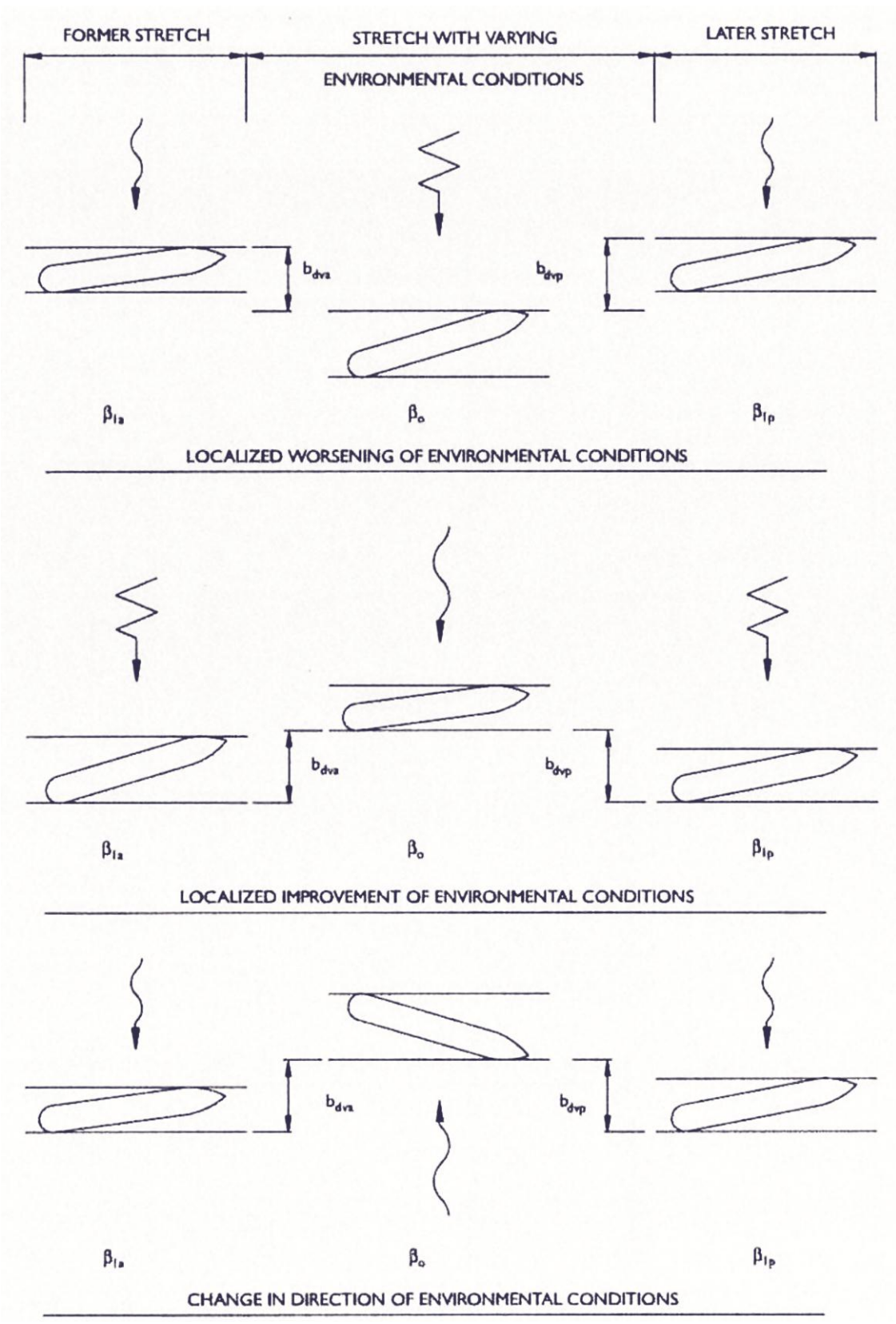

Figure G1-2: Navigation in straight stretches with varying environmental conditions along the track

Having determined the above, the additional width of the path swept by the vessel caused by navigating with an angle of drift will be available in the following three areas:

Description	For water space assessment	For above water space assessment
At the end of the prior stretch	$L_{pp} \cdot \sin \beta_{la} + b_{dva}$	$L_{oa} \cdot \sin \beta_{la} + b_{dva}$
At the beginning of the rear stretch	$L_{pp} \cdot \sin \beta_{lp} + b_{dvp}$	$L_{oa} \cdot \sin \beta_{lp} + b_{dvp}$
Varying stretch	$L_{pp} \cdot \sin \beta_0 + (b_{dva} \text{ or } b_{dvp})$	$L_{oa} \cdot \sin \beta_0 + (b_{dva} \text{ or } b_{dvp})$
Notes: 1. Use the worst of the two if they go in opposite directions or the sum of both if they go in the same direction. 2. $b_{dva} = b_{dv}$ in prior stretch, $b_{dvp} = b_{dv}$ in rear stretch or area of environmental condition variation.		

The fairway's axis is recommended to be kept unvarying along the whole stretch in order to correctly locate these widths and additional widths. Should the additional drift b_{dv} always occur in the same direction (for example, when a river flow affects the fairway), the additional width b_{dv} will be considered on the pertinent side of the fairway. If, on the other hand, the additional drift were to occur in either direction (for example, when caused by a tidal current affecting the fairway crosswise), the additional width b_{dv} must be calculated on the right and left of the fairway, applying the pertinent correction on each side; in this case, the overall width required may be diminished if a vessel reaction anticipation manoeuvre were to be effected, which were to at least partially correct the drift effect that might be expected in the varying environmental condition area. This operation would only be applicable in the event the manoeuvring were carried out with a pilot or captain experienced in the site being considered and should be incorporated into the port's Operating Rules should the fairway's additional width be optimised by using this procedure.

The additional width required for this straight stretch navigation with varying environmental conditions will be kept over the whole of the stretch affected plus an additional length (l) upstream and downstream with the value:

$$l = 2Vt_c \quad (G1-0)$$

where the maximum values admissible for the Design Vessel in keeping with the fairway's Operating Rules will be taken for the vessel's absolute speed V and the values given in this section for calculating b_{dv} will be taken for the time t_c . The transition to the width required in the fairway's prior and rear stretches will be effected with ground plan variations not greater than 1:10 (preferably 1:20) on each of the banks. Figure G1-3 shows the total width B_t over the varying stretch (B_{t0}) and over the prior (B_{tla}) and rear (B_{t1p}) stretches.

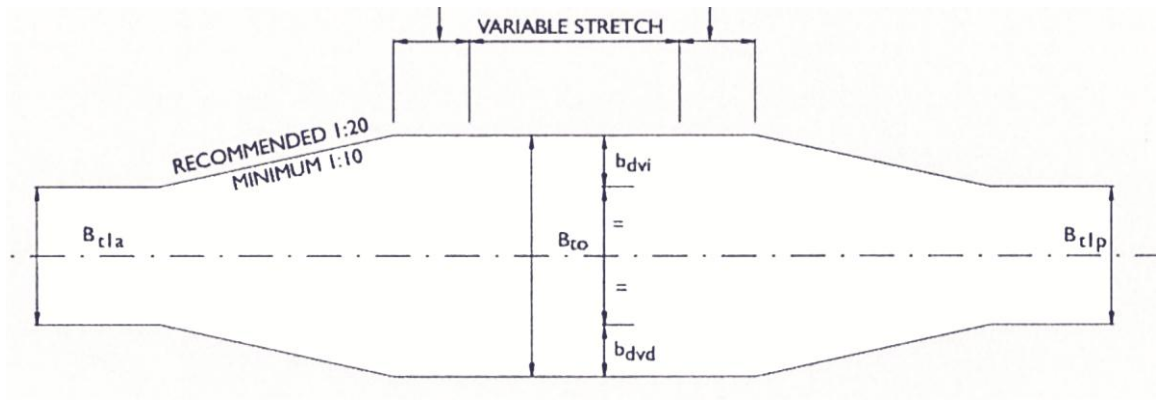

Figure G1-3: Configuration, straight stretches with varying environmental conditions, single navigation lane

3. Navigation in curved stretches with constant environmental conditions over the whole track

When navigating over curved stretches under constant environmental conditions over the whole track, the fairway's nominal width (B_n) will be determined with the same criteria as expounded for navigating over straight stretches, increasing the additional width b_d of the vessel's swept path produced by navigating with a drift angle and the additional width b_r due to the vessel's response speed by the following amounts:

- Increase in the vessel's additional swept path width caused by navigation with a drift angle.

This increase b_{dc} will be determined to correct the effect of the vessel's stern turning, by applying the following formula (see Figure G1-4):

$$b_{dc} = \sqrt{\left(R + \frac{B}{2}\right)^2 + (KL_{oa})^2} - \left(R + \frac{B}{2}\right) \quad (G1-0)$$

which may be approximated using the following simplified expression applicable to the assessment of both water and above water spaces:

$$b_{dc} = \frac{K^2 \cdot L_{oa}^2}{2R} \quad (G1-0)$$

where:

b_{dc} = Additional width of the path swept by the vessel and caused by curved stretch navigation.

R = Path radius for which the fairway's bending radius will be adopted.

K = Distance from the pivot point to the vessel's stern (or bow if greater) expressed as a fraction of the vessel's length overall (L_{oa}).

L_{oa} = Vessel's length overall

B = Vessel's beam

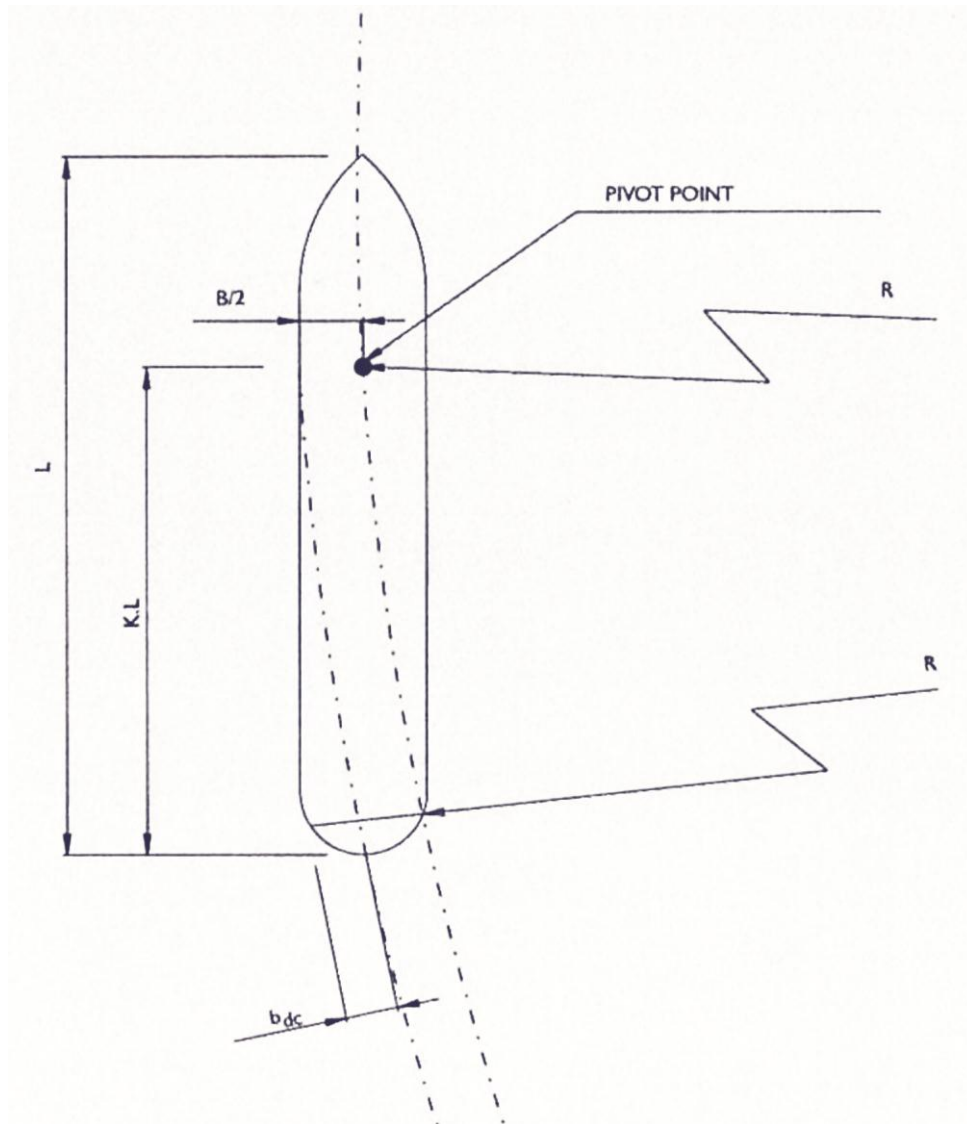

Figure G1-4: Additional width for stern turning

For vessels in which the pivot point is in the centre of the length, $K = 0.5$ and the foregoing expression becomes the following, which is that normally used in bibliography:

$$b_{dc} = \frac{L_{oa}^2}{8R} \quad (G1-0)$$

For larger displacement vessels with full underwater forms (oil tankers, bulk carriers, etc.) which are usually critical for dimensioning fairways, $K = 0.5$ if the ratio between the at-rest water depth (h) and the vessel's draught (T) is $h/T \leq 1.20$. However, if this ratio $h/T \geq 1.50$, then $K = 2/3$ and the foregoing expression then becomes:

$$b_{dc} = \frac{2L_{oa}^2}{9R} \quad (G1-0)$$

For fast boats (vessels with thin underwater hull shapes and pleasure boats) $K = 1$ and the additional width would be:

$$b_{dc} = \frac{L_{oa}^2}{2R} \quad (G1-0)$$

Should the fairway be dimensioned for general traffic, the additional width for largest displacement vessels with full underwater hull shapes which usually prove critical for determining the fairway's dimensions will be taken, using the value of b_{dc} calculated for $K = 0.5$ or $K = 2/3$ according to the design's h/T ratio (linear interpolation may be carried out for intermediate values):

- Increase in the additional width due to the vessel's response speed.

This increase (b_{rc}), which is additional to b_r defined for straight stretches, is established for taking into consideration the manoeuvring difficulties caused by the ship not immediately responding to the handler's instructions and, consequently, the pilot must anticipate the manoeuvre by deviating from the fairway's theoretical axis.

In the absence of more precise studies, provided the fairway's alignment is kept within the alignment recommendations given in section 1.2.3., this additional width may be as per the following values as a function of the Vessel's Beam (B), the Maximum Admissible Risk (E_{max}) during the Useful Life of the design being analysed, determined with the criteria as established in Table G1-2, and of the vessel's manoeuvrability (see the section for calculating (br) in this same point):

Vessel's manoeuvrability	b_{rc}
Good	$0.20 (1.50 - E_{max}) B$
Medium	$0.40 (1.50 - E_{max}) B$
Bad	$0.80 (1.50 - E_{max}) B$

Medium vessel manoeuvrability conditions will be used for dimensioning fairways open to general traffic. Having determined the fairway's overall width at the bend (B_{tc}) and knowing the width of the straight legs (B_{tr}) running into it (which may be different in one or the other leg), its geometrical configuration and the alignment of its banks are usually determined by one of the following methods:

- Straight banks
- Curved banks

The geometric characteristics of the systems most used in both methods are shown in Figure G1-5 and G1-6. The straight bank methods are those that worst conform to the alignment's geometric conditions whilst at once having the disadvantage of causing unfavourable secondary currents. Nevertheless, they are simpler to navigation mark and to dredge. For curved bank methods, assuming that the track radius is not strict, it is preferable to develop solutions in which the additional width is located inwards of the bend (1st and 3rd configuration in the figure) because with the vessel having the inside bank as the navigation reference, it anticipates manoeuvres for taking the bend by gradually adjusting the rudder angle δ_R .

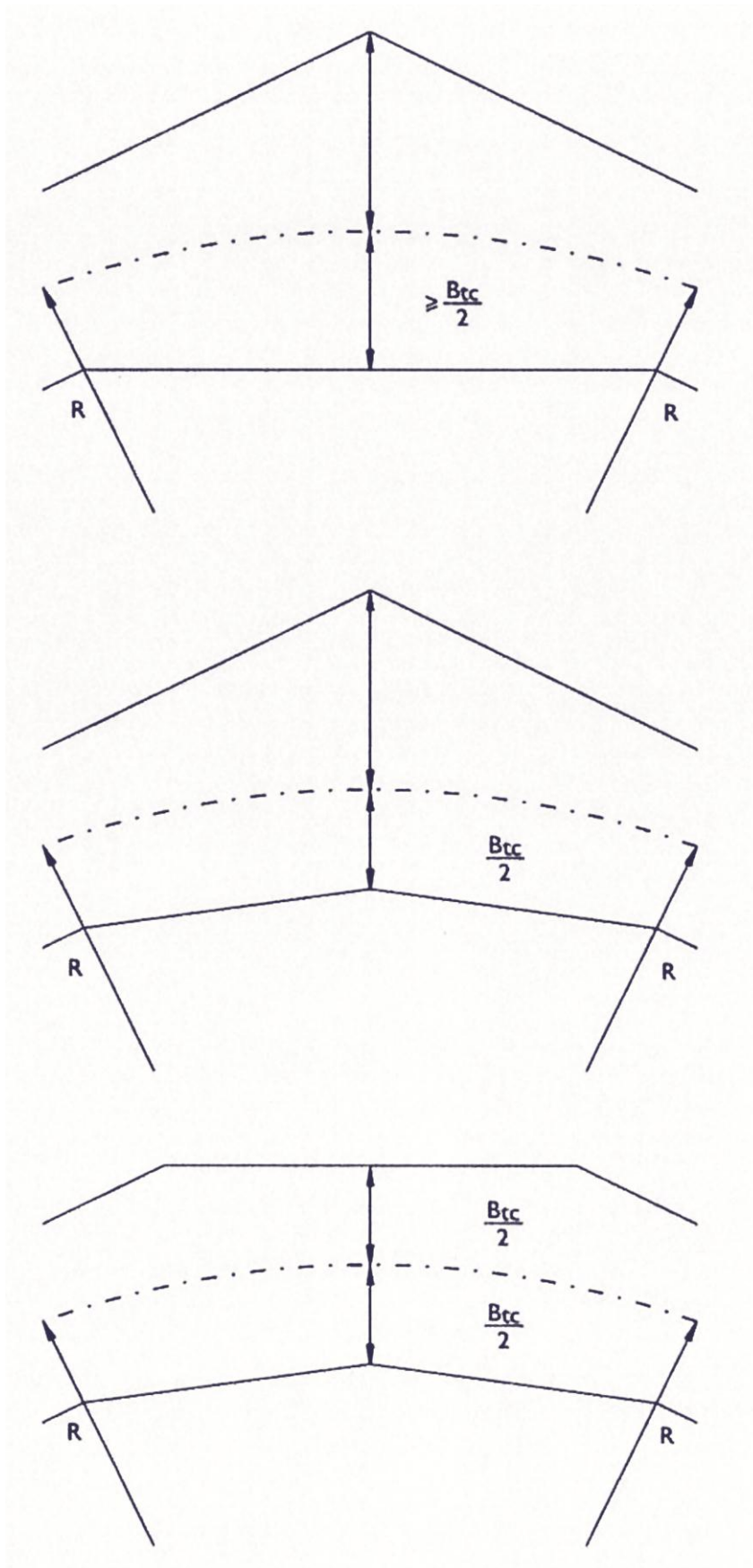

Figure G1-5: Geometric configuration, curved stretches, solutions with straight banks

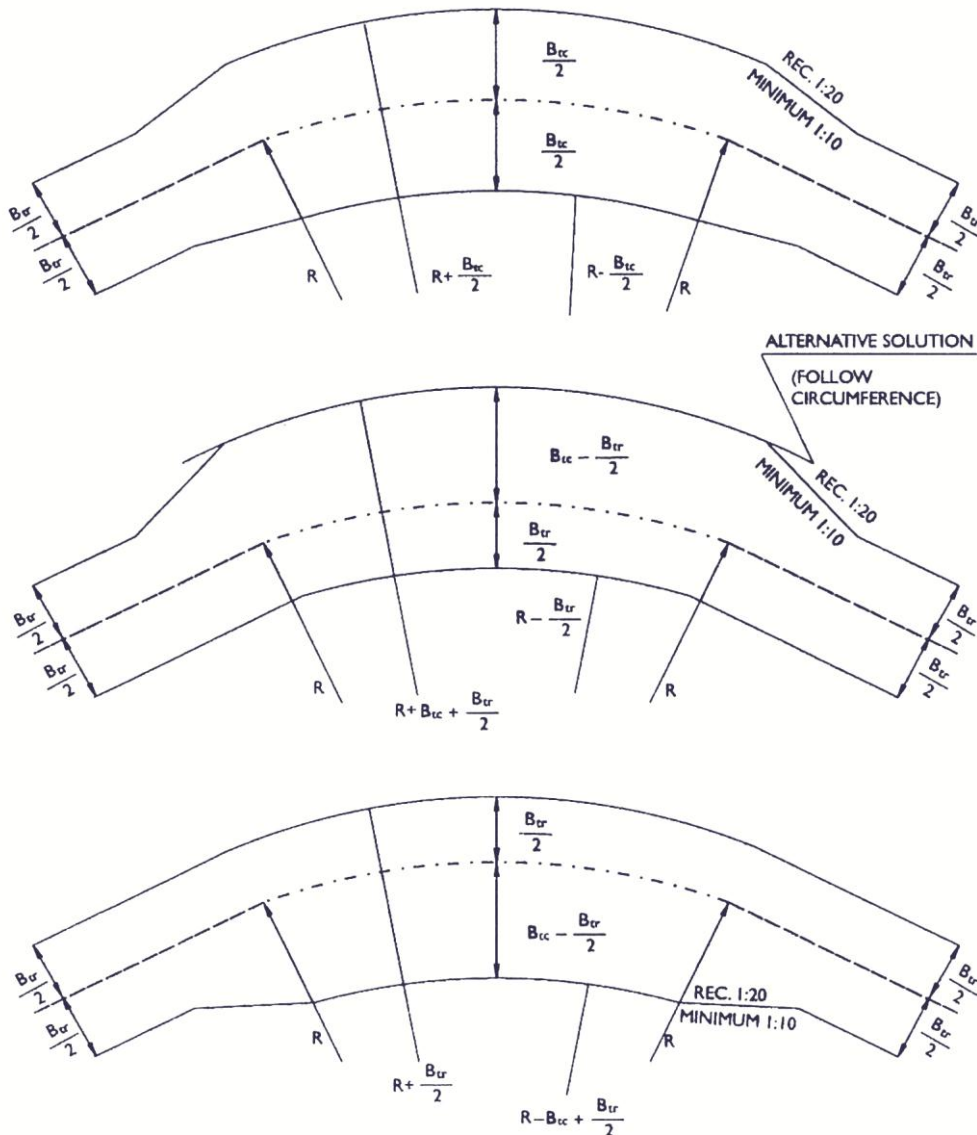

Figure G1-6: Geometric configuration, curved stretches, solutions with curved banks

4. Navigation in curved stretches with environmental conditions varying over the track

When navigating over curved stretches with environmental conditions varying over the whole track, the fairway's width will be determined by adding the needs for space of both circumstances to the navigation width in straight stretches, as defined in points 2 and 3 of this sub-section G1.2.4.2. The mathematical formulation of the fairway's nominal width (B_n) in the most complex case will be:

$$B_n = B + (b_d + b_{dvi} + b_{dvd} + b_{dc}) + 2(b_e + b_r + b_{rc} + b_b) + (rh_{sm} + rh_{sd})_i + (rh_{sm} + rh_{sd})_d \quad (G1-0)$$

where all symbols have the meaning as given previously.

The resulting geometrical configuration will be established by applying the criteria as given for both circumstances but no single general solution can be found in the light of the variety of cases which could arise.

Two-Lane Fairways

The width of a two shipping lane fairway will be determined in a way similar to that defined for single lane fairways by firstly analysing navigation in straight stretches under constant environmental conditions and then addressing the effect of varying environmental conditions on navigation over the track or navigating round a bend. In view of the fact that these two cases do not display any peculiarity deriving from being a fairway with two or more shipping lanes, except, of course, to consider additional widths that may be given to each lane, only navigation over straight stretches under constant environmental conditions is analysed in detail.

The general design criterion for all cases consists in dimensioning each lane separately, setting up an intermediate passing distance with a different width (b_s) according to the fairway and traffic characteristics and maintaining the additional safety clearance on each side of the fairway (rh_{sm}) to allow a vessel to navigate without being affected by bank suction and rejection, as well as the Safety Margin (rh_{sd}) which shall always be available between the fairway's slopes or structural boundaries. Both the Safety Clearance (rh_{sm}) and the Safety Margin (rh_{sd}) may be different on either bank according to their nature and the fairway's operating conditions.

1. Straight stretch navigation with constant environmental conditions over the track

In the case whereby the environmental, maritime and meteorological conditions (winds, waves and currents) are constant along the track, the nominal width of a straight stretch fairway with two lanes dimensioned for the same design vessel will be determined as the sum of the following components (Figure G1-7):

$$B_n = 2 \left[B + b_d + 2(b_e + b_r + b_b) \right] + b_s + (rh_{sm} + rh_{sd})_i + (rh_{sm} + rh_{sd})_d \quad (G1-0)$$

where all the expressions have the same meaning as in point a.1 in section G1.2.4.2 and b_s is the passing distance between the two lanes, calculated as the sum from the two factors (see table below) based on the assumption that the operation is undertaken with pilots or captains experienced at the project site. The vessel's absolute speed will be the highest compatible with the fairway's Operating Rules and the traffic density will be determined by taking the vessel motion in both directions into consideration (excluding fishing and pleasure boats, unless they are the fairway's Design Vessel).

Description	b_s	
	Fairway in exposed areas	Fairway in sheltered waters
Fairways with overtaking forbidden (only passing)		
• First factor: Vessel's absolute speed		
• Greater than 6 m/s	2.0 B	-
• Between 4 and 6 m/s	1.6 B	1.4 B
• Less than 4 m/s	1.2 B	1.0 B
• Second factor: Traffic density		
• 0-1 vessels/hour	0.0 B	0.0 B
• 1-3 vessels/hour	0.2 B	0.2 B
• > 3 vessels/hour	0.5 B	0.4 B
Note: For fairways with overtaking allowed: Increase the foregoing factors by 50 %.		

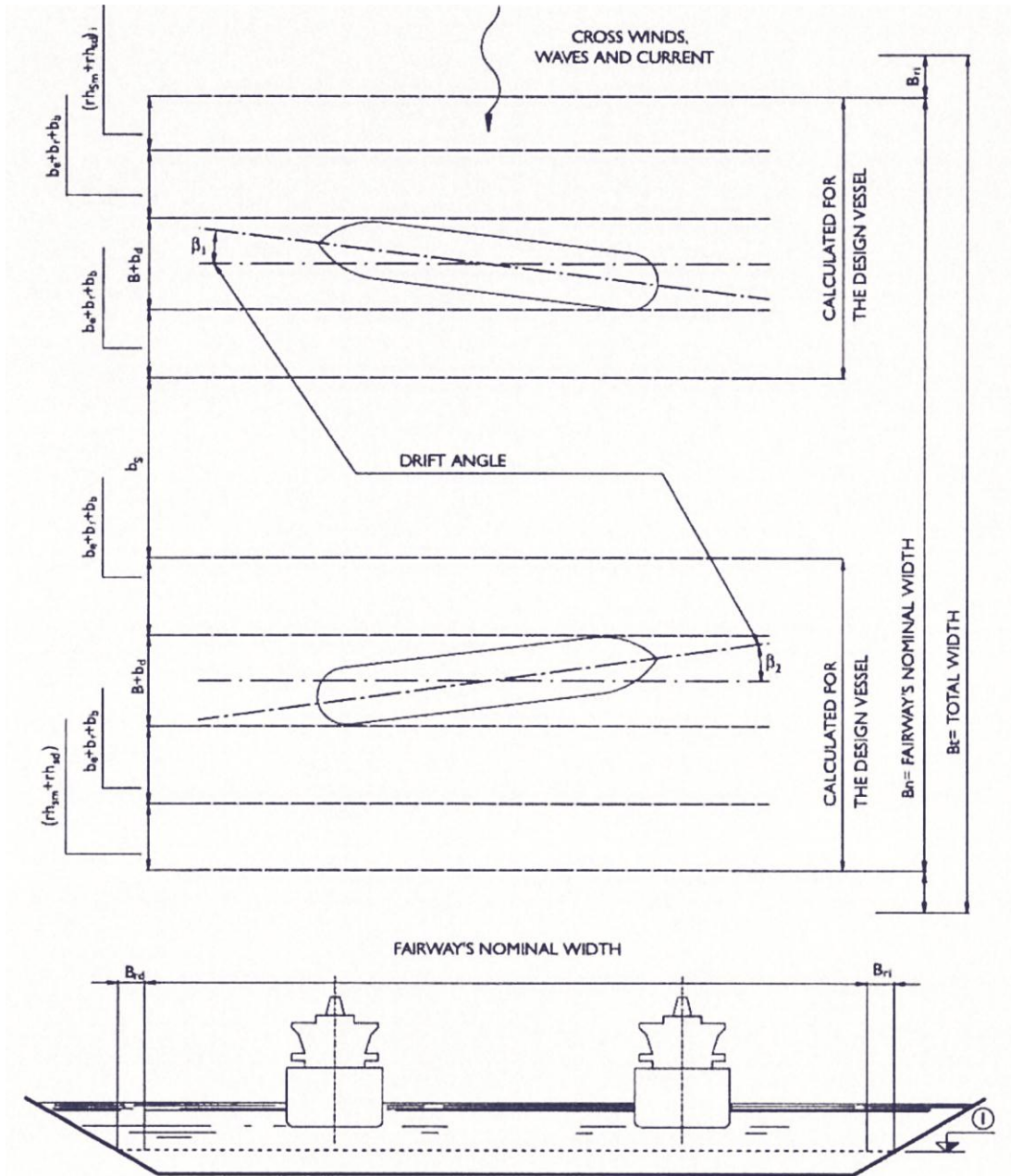

(I) Fairway's nominal depth.

Figure G1-7: Width for straight stretch fairways with two navigation lanes. Operation with the same tonnage.

Should the fairway's Operating Rules establish that large displacement vessels are only allowed to pass or overtake smaller vessels up to a certain range, the fairway's nominal width might be adjusted to the following dimensions (Figure G1-8):

$$V_{Cr} = \begin{cases} 2[B + b_d + 2(b_e + b_r + b_b)]_{design\ vessel} + [b_s]_{design\ vessel} \\ + [B + b_d + 2(b_e + b_r + b_b)]_{smaller\ vessel} \\ + [(rh_{sm} + rh_{sd})_i + (rh_{sm} + rh_{sd})_d]_{design\ \&\ smaller\ vessels} \end{cases} \quad (G1-0)$$

where all expressions have the meanings as defined in the foregoing paragraph.

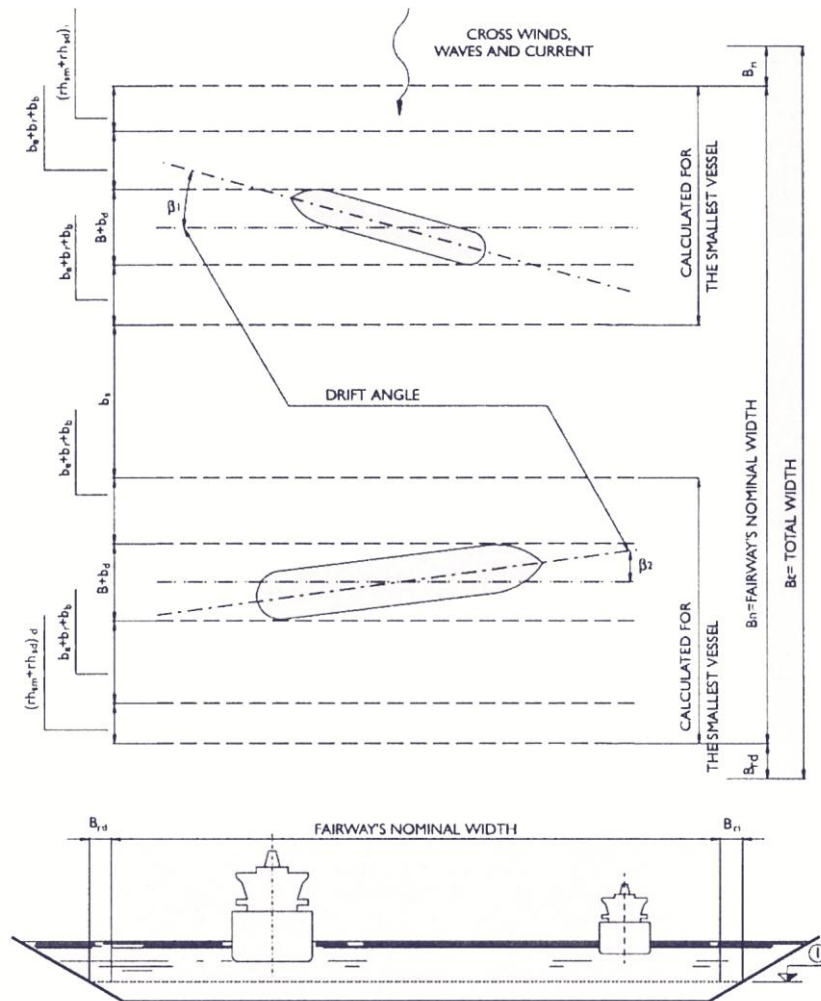

(I) Fairway's nominal depth.

Figure G1-8: Width for straight stretch fairways with two navigation lanes. Operation with two vessels of different tonnage.

2. Straight stretch navigation with environmental conditions varying over the track

The criteria established in Section G1.2.4.2 concerning 'Two-Lane Fairways, Straight Stretch Navigation with Constant Environmental Conditions' will be retained without considering anything further than the additional widths b_{dv} of each of the vessel's swept paths as calculated by Eq. G1-11. These additional widths will be kept at a length equal to that established in this section, i.e. over the whole stretch affected by the varying environmental conditions plus an additional length (l) upstream and downstream with a value as defined in Eq. G1-12.

In order to correctly locate the resulting widths taking into account the different additional widths that may be required on either side, it is generally recommended to keep the fairway's axis constant along the whole stretch (passing distance axis if both lanes are dimensioned for the same design vessels, or a line equidistant from the edges of the fairway's nominal width otherwise). Transition to the width required in the fairway's prior and rear stretches will be made with ground plan variations not greater than 1:10 (preferably 1:20) on each of the banks (Figure G1-9). This transition involves changing the axes of both shipping lanes in relation to the straight alignments they had upstream or downstream of the stretch with varying environmental conditions, which is a condition

required for cutting dredging costs; should any of the upstream or downstream stretches not have area and depth restrictions (for example, in approach channels), keeping the straight alignment of the axes of each of the shipping lanes is recommended, separating them from each other the greatest distance required in this stretch to facilitate the fairway's navigation and navigation marking.

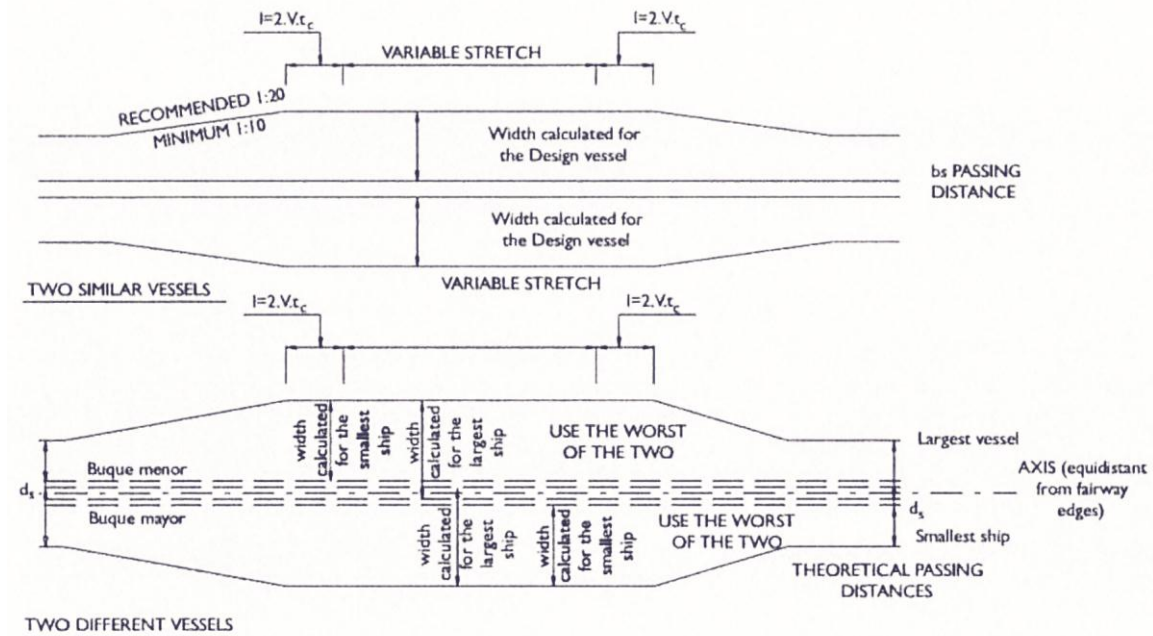

Figure G1-9: Configuration, straight stretches with varying environmental conditions, two lanes

3. Navigation in curved stretches with constant environmental conditions over the track

The criteria established in Section G1.2.4.2 concerning 'Two-Lane Fairways, Straight Stretch Navigation with Constant Environmental Conditions' will be retained without considering anything further than the additional widths b_{dc} and b_{rc} as calculated in 'Single Lane Fairways' for each of the two shipping lanes.

The scheme in Figure G1-5 and G1-6 will be followed for defining the bend's geometric configuration and the routing of the banks, plotted from the axis of the inside lane of the bend, which is the strictest for fulfilling minimum radius stipulations.

4. Navigation in curved stretches with varying environmental conditions over the track

When navigating in curved stretches with varying environmental conditions over the track, the fairway's width will be determined by adding the requirements of additional width needed for curved tracks and varying environmental conditions to the navigation width in straight stretches, as defined previously.

The mathematical formulation of the fairway's nominal width (B_n) in the most complex hypothesis corresponding to the case whereby the two shipping lanes are dimensioned for the same Design Vessel would be:

$$B_n = 2 \left[B + b_d + b_{dvi} + b_{dvd} + b_{dc} + 2(b_e + b_f + b_{rc} + b_b) \right] + b_s + (rh_{sm} + rh_{sd})_i + (rh_{sm} + rh_{sd})_d \quad (G1-0)$$

The resulting geometric configuration will be established by applying the criteria set down for both cases, with no general solution being possible in the light of the variety of hypotheses which may be arise.

Vessel Overtaking and Passing Stretches In Single Lane Fairways

In the case of single shipping lane fairways of a considerable length and transit time, it may be advisable to have specific stretches dimensioned for two fairways in which vessel overtaking and passing manoeuvres may be undertaken. Using these stretches will require vessel control systems to be set up from land or operation with on board pilots.

Should this solution be chosen, the two fairway stretches will be set up straight, with constant environmental conditions throughout the track and avoiding curved stretch solutions or varying environmental conditions.

The width of the two shipping lane stretch will be dimensioned with the criteria as defined in 'Two-Lane Fairways, Straight Stretch Navigation with Constant Environmental Conditions', taking into account the fact that the manoeuvre may be performed by two Design Vessels or by one Design Vessel simultaneously with another, smaller vessel.

The same straight fairway alignment will be kept to in the double lane stretch, which will therefore coincide with the axis of the passing distance in the event of dimensioning for two vessels the same or with the line equidistant from the edges of the fairway's nominal width otherwise. Dimensioning criteria, general configuration and bank transitions will be established as follows:

Stretch for Vessel Overtaking

It will be assumed that vessels in the prior stretch navigate at a reduced speed (40 % of the absolute maximum speed admissible in the fairway, V_{sr}) keeping a clear distance between both vessels equal to the stopping distance D_p plus the area covered during a reaction time t of 60 sec. This relative position will be kept to until the vessel overtaken is in the double lane stretch.

As from that position, it will be assumed that the vessel overtaken keeps to the reduced speed (40 %) whilst the vessel that has overtaken it travels at a mean speed double the former (80 % of the absolute maximum speed admissible in the fairway), which rate will be maintained for a time T_a until this vessel exceeds the overtaken one by a clear distance equal to that considered at the beginning of the manoeuvre. When this final position is reached, the vessel overtaken must still keep in the double lane stretch. The stretch will be dimensioned with these assumptions so that the spaces available are at least twice as long as the theoretically necessary. Width transitions will be made with ground plan variations not greater than 1:10 (preferably 1:20) on each of the sides. See Figure G1-10 for the case where the two ships have the same dimension L_{oa} (length overall).

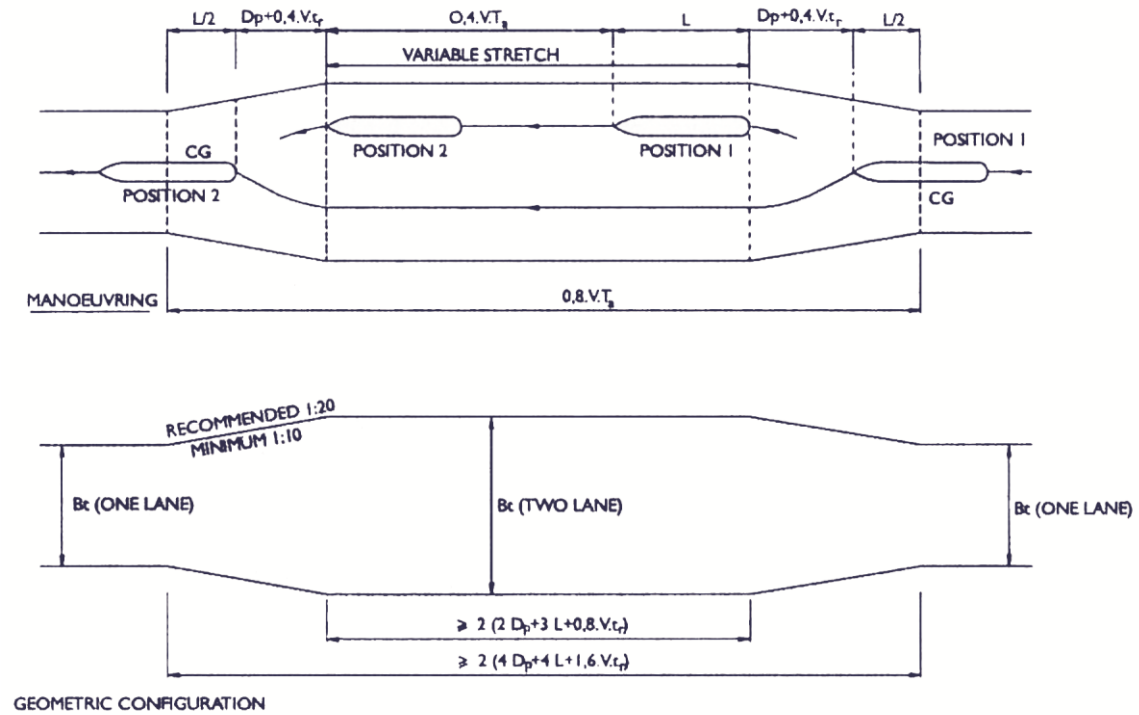

Figure G1-10: Vessel overtaking stretch

Stretch for Vessel Passing

Considering the length of the double lane stretch depends on the vessels reaching the beginning of the stretch either at the same time or with a lag, it will be assumed, as the most unfavourable hypothesis, that this coincidence does not occur and, therefore, either of the two vessels accessing the passing area with a reduced speed (40 % of the absolute maximum admissible in the fairway, V , can stop at least in a waiting area (quay, mooring area, anchorage, etc.) located at the beginning or end of the double width area (preferably at the place which allows vessels to depart without waiting and that therefore entering vessels are the ones which must wait), so the longitudinal development of the stretch will need space for the stopping distance (D_p) plus the area covered during a reaction time t_r of 60 sec plus the design vessel's length overall L_{oa} . The stretch will be dimensioned with these assumptions so that the areas available are at least twice as long as the theoretically necessary. Width transitions will be made with ground plan variations not greater than 1:10 (preferably 1:20) on each of the sides (Figure G1-11).

The spaces necessary for the waiting area will be developed at the side of the fairway, keeping a reserve space of $2.5 B$ (B = design vessel beam) between the edge of the fairway and the most advanced position the anchored or moored vessel may reach.

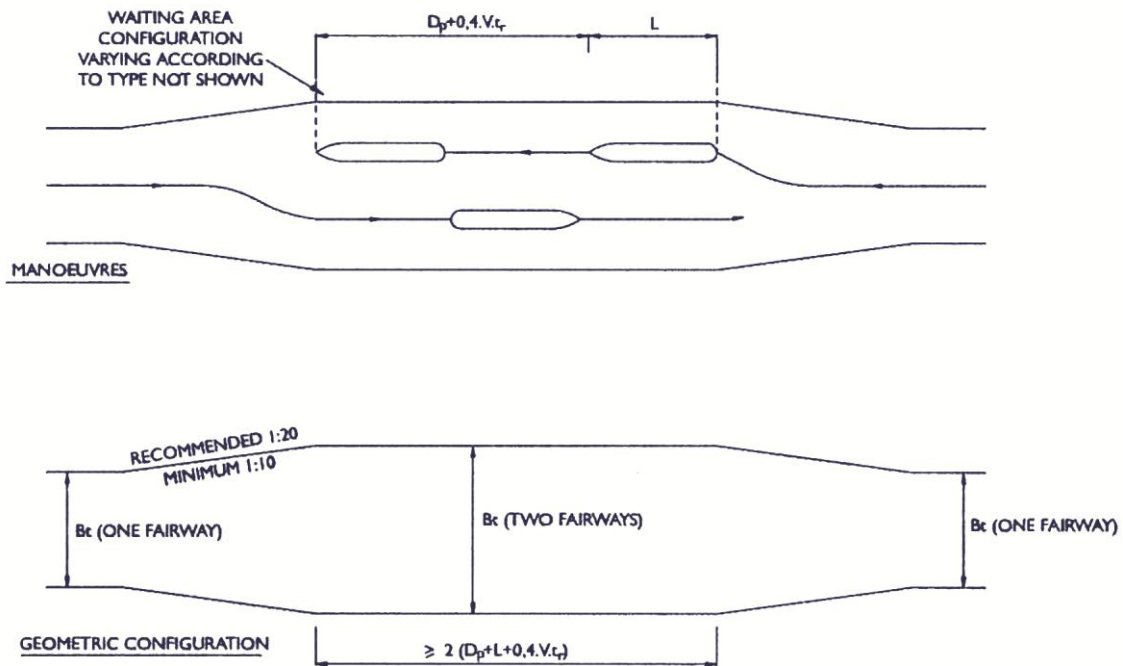

Figure G1-11: Vessel passing stretch

Developing Navigation Lanes over the Slopes of the Main Fairway's Banks

In the usual case that the fairway has sloping banks, fairways can be set up for smaller boats with maximum lengths of 20 m (fishing boats, pleasure boats, etc.), locating them parallel to and outside the main fairway, taking advantage of the depths available on these slopes. Should this solution be chosen, it will be considered that the main fairway and smaller boats are always separate, therefore keeping a passing distance with a width b_s between them (see point b.1 of this sub-section). The due navigation marking system will be implemented to prevent navigation errors. Should these specific fairways for smaller boats be set up, it will be compulsory for this type of boat to always use these lanes even though there is no traffic in the main fairway.

Fairways with More Than Two Navigation Lanes

Should fairways with more than two navigation lanes be designed, the design criteria established for two lane fairways will be kept to, so that each lane can attend to its function separately.

The geometric configurations will be designed so that vessels can navigate in as simplified a manner as possible, considering the navigation marking system available.

G1.2.4.3 Determining Nominal Width B_n by the Semi-Probabilistic Method

A fairway's geometric design in this procedure is mainly based on statistically analysing the areas swept by vessels in the different manoeuvres considered, which, should a sufficient number of manoeuvre repetitions be available, will enable the resulting design to be associated to the risk pre-set in each case.

This method may be practically applied on the basis of simulator studies, reduced scale tests, real-time measurements or similar procedures, which may reproduce the problem

raised with greater or lesser accuracy. Part 9 of the ROM gives the main aspects of Simulation Models, which are the most frequently used tool for this kind of study.

The characteristics of the system used and its limitations must be accurately known before using this method. Those aspects of the situation which are not reproducible with the model used must be determined (e.g. navigation marking and the inaccuracies associated to it) since all conditions that cannot be modelled must be dealt with by other procedures. The scheme followed in this ROM is that the same criteria defined for the deterministic model will be used for assessing all aspects that simulation models do not consider; in particular, Safety Margins (rh_{sd}) will be assessed exactly the same in both methods.

The analysis carried out with these procedures usually examines different vessel paths, covering complete stretches of the fairway, in which straight or curved stretches may occur, as well as constant or varying environmental conditions along the track, which may be studied overall whilst more accurately analysing the interaction between them. Most present day simulators analyse the case of one fairway on each path where there is only one vessel sailing and, therefore, in general, the study of fairways with two navigation lanes, in any of the hypotheses of section G1.2.4.2 will require an intermediate passing distance with a width (b_s) calculated as shown there to be taken into account.

The general design procedure will comprise the following phases:

1. Understanding the model to be used and its limitations, especially those aspects which cannot be reproduced in the study, which shall have to be addressed by deterministic procedures.
2. Knowing the characteristics of the water and its surroundings (geometric definition of the track, bathymetry and water levels, marine environment existing in the area, etc.). The level of definition required in this respect may significantly vary according to the simulation system used.
3. Defining the marking and navigation marking systems which may be set up, as well as the way in which they are incorporated into the simulator.
4. Defining limit environmental operating conditions according to the type and dimensions of vessels, tugs available or any other particular condition that may be defined in each case.
5. Defining the tugs available and their participation in manoeuvres as a function of the type and dimensions of vessels, environmental conditions existing or any other condition that may be established.
6. Specifying the scenarios which will be reproduced on the simulator. Scenario is taken to mean the set of conditions defining a manoeuvre (which will be repeated several times to statistically process it), comprising at least the following aspects:
 - The type of vessel representative of the category of ships it is wished to study.
 - The limit environmental operating conditions representative of the stretch to be studied.
 - Tugs and other aids to navigation which will be available in this operation.
7. Defining the number of passes to be made on the simulator repeating the manoeuvre for a given scenario. To the extent whereby a greater number of passes is available,

the study's accuracy will increase with the counterpart of increasing simulation costs. Between 12 and 15 passes are recommended for drafting final designs.

8. Specifying the cross-sections of the fairway in which the vessel occupied area will be assessed (critical sections, all cross-sections at a pre-set geometric or time separation and even a continuous record of all paths swept by the vessel in each of the tracks may be obtained).
9. Statistically analysing the results obtained on the simulator in keeping with the purpose of the study. If the aim is only to determine the fairway's width, interest will only lie in the limit values of occupied area on the fairway's port or starboard sides; if, in addition, it is wished to optimise the fairway's track, the vessel's centre of gravity deviations from the pre-set reference track must be analysed (Figure G1-12). In all cases, the process will involve determining the functions of density and exceedance, adjusting different distribution functions (Normal, Gumbel, Weibull, etc.) for each of the study's cross-sections, determining their coefficients of correlation and choosing those functions which best fit, which will generally be those of a symmetric type for studying the centre of gravity's position and those of an asymmetric type when occupied area is analysed on either of the two sides.
10. Choosing the distribution functions (preferably one type for the sides and another for the centre of gravity, if necessary). The mean values of the centre of gravity deviation density function will be used in each section to optimise the track axis. The exceedance probability function will be used to analyse the fairway's width and the most unfavourable 95 % confidence intervals will also be determined (those where highest occupancy occurs). The probability of exceedance (p_{ij}) that the fairway is exceeded in that section by a vessel of type (i) in the operating conditions of the stretch (j) – scenario analysed – will be calculated on these confidence intervals using the following steps:

- a) Define the useful Lifetime (L_i) of the area (Table G1-1).
- b) Define the number of types of ships (i) and scenarios of the operation (j) that will be analysed.
- c) Define the number of ships (N_{ij}) that corresponds to every combination (ij).
- d) Calculate the probability of exceedance (p_{ij}) in the manoeuvring of a ship of type (i) in the scene (j) that overcomes the threshold dimension (X_o).

$$p_{ij} = P(X > X_o) \quad (G1-0)$$

This data is obtained from the distribution functions of the case (ij) discussed in #9 above.

- e) Calculate the probability of exceedance (E_{ij}) that a ship in all the manoeuvres (N_{ij}) of the ship type (i) in the scene (j) overcomes the threshold dimension (X_o).

$$E_{ij} = 1 - (1 - p_{ij})^{N_{ij}} \quad (G1-0)$$

- f) Calculate the probability of exceedance (E) that any type of ship in any scene that overcomes the threshold dimension (X_o).

$$E = 1 - \prod_j (1 - E_{ij}) \quad (G1-0)$$

where Π_{ij} is the product of all values of $(1-E_{ij})$ for all types of vessels in all scenarios. Should this calculated risk be higher than the maximum acceptable E_{max} in Table G1-2, a new value of the variable (X_o) must be considered until this requirement is achieved.

The single shipping lane fairway's nominal width determined by this semi-probabilistic method will be:

$$B_n = [\text{width between sides calculated statistically as a function of the preset risk } E] + [\text{additional widths due to effects not addressed on the simulator which will be calculated with criteria as established by the deterministic method}] + [\text{Safety Margin } rh_{sd} \text{ assessed with the criteria established by the deterministic method}].$$

The fairway's nominal width B_n for two or more shipping lane fairways in any of the types as defined in points 1, 2, 3 or 4 of sub-section G1.2.4.2.a will be calculated by generalising the foregoing criterion as a function of the simulation model used and including in any case an intermediate passing distance of width b_s calculated with the criteria as given for the deterministic method. These schemes will be kept to for the geometric ground plan configurations shown in Figures G1-9, G1-10 and G1-11, unless others based on simulation studies with the design criteria in the ROM for semi-probabilistic methods are justified.

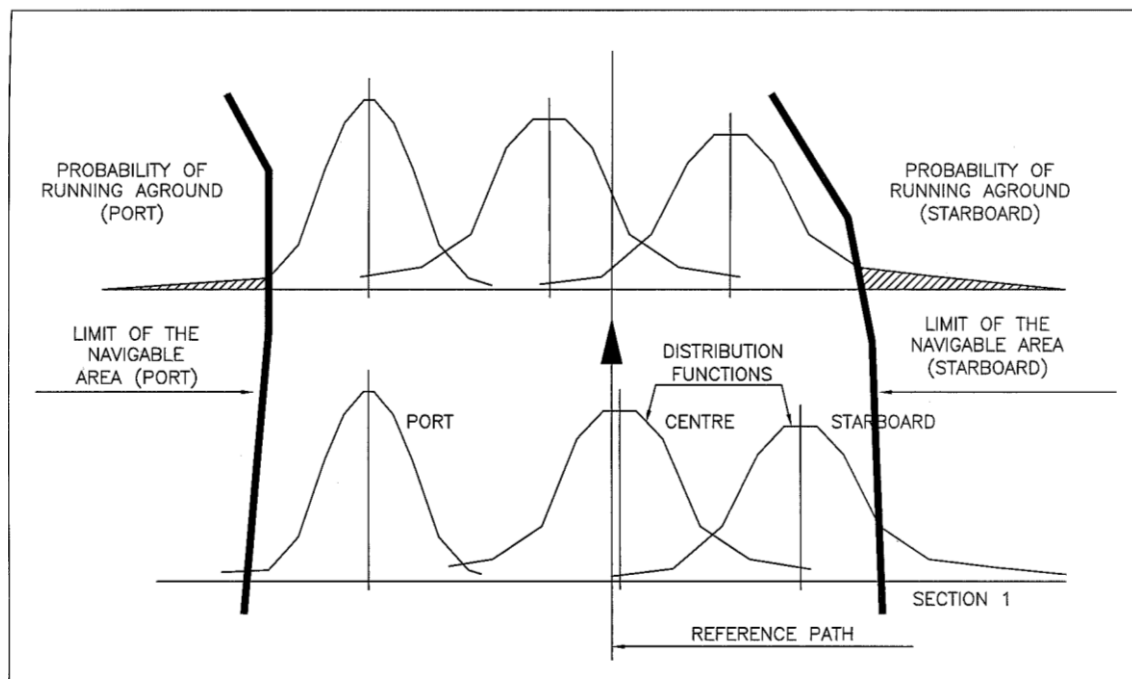

Figure G1-12: Sizing of the fairway by the semi-probabilistic method

G1.2.5 Point of No Return

In practice, there will be what is known as a point of no return in all port approach fairways, as from which a vessel will not be able to stop (without obstructing the fairway), to turn to change direction, or anchor leaving the navigation route free and, consequently, it must continue on its course to the harbour. This point of no return shall be located as close as possible to the actual harbour entrance, providing areas to allow turning, anchoring, provisional mooring manoeuvres or those provided for in each case, the dimensions of which will be determined as indicated in other sections in this Recommendation. The spaces required for anchorages and mooring areas are developed at the side of the fairway, keeping a reserve space of $2.5 B$ (B = fairway design vessel's beam) between the edge of the fairway and the most advanced position the anchored or moored vessel can reach. The space necessary for the turning area may be developed on the fairway should traffic density be equal to or less than 1 vessel/hour, considering two way vessel motion. Setting up the turning area outside the fairway is recommended for higher traffic densities so that it remains functional at all times.

In the case of very long fairways and as a function of the traffic intensities occurring, it may be necessary to arrange several areas along the fairway with the same purpose as a point of no return.

14 G2: JAPANESE NEW DESIGN METHOD OF FAIRWAY WIDTH DETERMINATION AT CONCEPT DESIGN

New design standards for the port and harbour have been issued currently in Japan [Ohtsu et al., 2006 ; MILT, 2007] in which an advanced method of the fairway width determination for the concept design use has successfully been developed on the basis of the performance-based approach. In this appendix, design procedures of the fairway width determination are presented in detail.

G2.1 Basic Formulae of Fairway Width Determination

The fairway width W may generally be determined by the following basic equation:

$$W = (W_{BM} + W_{IF}) C_{SF} \quad (G2-0)$$

where:

W_{BM} : width of basic or fundamental manoeuvring lane

W_{IF} : additional width to account for interaction forces

C_{SF} : safety factor based on risk level

The width of a fundamental manoeuvring lane $W_{BM} \lim_{X \rightarrow \infty}$ consists of four basic elements:

$$W_{BM} = a(W_{WF} + W_{CF} + W_{YM} + W_{DD}) \quad (G2-0)$$

where:

W_{WF} : additional width to account for wind forces

W_{CF} : additional width to account for current forces

W_{YM} : additional width to account for yawing motion

W_{DD} : additional width to account for drift detection

Furthermore, the additional width requisite against interaction forces consists of the following three elements:

$$W_{IF} = W_{BA} + bW_{PA} + cW_{OV} \quad (G2-0)$$

where:

W_{BA} : additional width to account for bank effect forces

W_{PA} : additional width to account for two-ship interaction in passing

W_{OV} : additional width to account for two-ship interaction in overtaking

Factors for specifying the type of the channel a , b and c in Eqs. G2-2 and G2-3 are given as:

$$\begin{aligned} a = 1, b = 0 \text{ and } c = 0 & \quad \text{1-way channel} \\ a = 2, b = 1 \text{ and } c = 0 & \quad \text{2-way channel} \\ a = 4, b = 1 \text{ and } c = 2 & \quad \text{4-way channel} \end{aligned}$$

G2.2 Ship Types

Fifteen ships covering a wide range of ship types and sizes are selected as the type ships, principal particulars of which are given in Table G2-1 together with hydrodynamic derivatives. Extensive computations are made with respect to the width requisite against the wind forces and the interaction forces and the results are summarised in the tables for the practical design use without computers.

	Ship Type	GT/DWT	Loa(m)	Lpp(m)	B(m)	do(m)	Cb	Y'v	N'v	Y'δ	
1	Cargo Ship	5,000 GT	109.0	103.0	20.0	7.0	0.7402	-1.688	-0.590	-0.0723	0.0362
2	Small Cargo Ship	499 GT	63.8	60.4	11.2	4.2	0.5395	-1.653	-0.597	-0.0881	0.0441
3	Container Ship (Over Panamax)	77,900 DWT	299.9	283.8	40.0	14.0	0.6472	-1.340	-0.457	-0.0720	0.0360
4	Container (Panamax)	59,500 DWT	288.3	273.0	32.2	13.3	0.6665	-1.312	-0.449	-0.0781	0.0391
5	Very Large Bulk Carrier	172,900 DWT	289.0	279.0	45.0	17.8	0.8042	-1.612	-0.562	-0.0699	0.0350
6	Large Bulk Carrier (Panamax)	74,000 DWT	225.0	216.0	32.3	13.5	0.8383	-1.587	-0.553	-0.0696	0.0348
7	Small Bulk Carrier	10,000 DWT	125.0	119.2	21.5	6.9	0.8057	-1.551	-0.519	-0.0773	0.0387
8	VLCC	280,000 DWT	333.0	316.0	60.0	20.4	0.7941	-1.658	-0.564	-0.0880	0.0440
9	Small Tanker	6,000 DWT	100.6	92.0	20.0	7.0	0.7968	-1.835	-0.640	-0.0811	0.0406
10	Large Pure Car Carrier	21,500 DWT	199.9	190.0	32.2	10.1	0.6153	-1.417	-0.484	-0.0731	0.0365
11	Pure Car Carrier	18,000 DWT	190.0	180.0	32.2	8.2	0.5470	-1.287	-0.427	-0.0753	0.0376
12	LNG Ship	69,500 DWT	283.0	270.0	44.8	10.8	0.7000	-1.213	-0.382	-0.0762	0.0381
13	Refrigerated Cargo Carrier	10,000 GT	152.0	144.0	23.5	7.0	0.7526	-1.372	-0.451	-0.0705	0.0353
14	Passenger Ship (2shafts 2propellers)	28,700 GT	192.8	160.0	24.7	6.6	0.6030	-1.214	-0.387	-0.1000	0.0500
15	Ferry Boat (2shafts 1propellers)	18,000 GT	192.9	181.0	29.4	6.7	0.5547	-1.125	-0.354	-0.0875	0.0437

Table G2-1: Principal particulars of ship types

G2.3 Estimation of Fundamental Manoeuvring Lane

G2.3.1 Width Requisite against Wind and Current Forces

In order to keep on a straight line in the fairway centre under the external forces, the ship should be operated by the check helm to run in an oblique condition with some drift angle with respect to its heading as shown in Figure G2-1, so that the forces acting on the ship, namely the hull forces, the rudder forces and the external forces, can be balanced. The width requisite against the wind and current forces $W_{WF} + W_{CF}$ may be calculated with the use of the drift angle β as:

$$W_{WF} + W_{CF} = L_{oa} \sin \beta + B \cos \beta \quad (G2-0)$$

where:

L_{oa} and B denote the overall length of ship and the breadth of ship respectively and the drift angle β may be given as:

$$\beta = \beta_1 + \beta_2 \quad (G2-0)$$

where:

β_1 : drift angle due to wind forces

β_2 : drift angle due to current forces

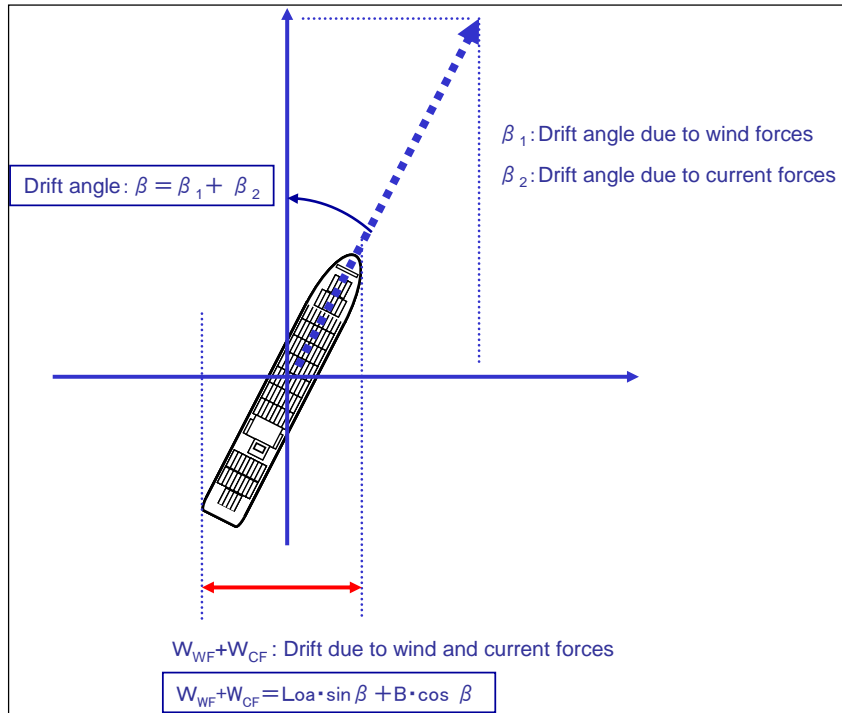

Figure G2-1: $W_{WF} + W_{CF}$: Width requisite against wind and current forces

G2.3.1.1 Drift Angle due to Wind Forces

Table G2-2 gives the drift angle due to the wind forces together with its corresponding check helm for the 15 ships, which are obtained by the calculation presented in Section G2.8 for the shallow water of $h/T = 1.2$ (h : the water depth T : the ship draught). In Table G2-2, computations are given at each 15 deg of the relative wind direction form 0 deg (the head wind) to 180 deg (the tail wind).

Ship Type		Relative Wind Direction(degree)														
		0	15	30	45	60	75	90	105	120	135	150	165	180		
1 Cargo Ship	β_1 (degree)	0.000	0.003	0.007	0.011	0.014	0.017	0.017	0.015	0.011	0.007	0.003	0.001	0.000		
	δ_1 (degree)	0.000	0.017	0.049	0.102	0.169	0.233	0.276	0.284	0.257	0.204	0.138	0.068	0.001		
2 Small Cargo Ship	β_1 (degree)	0.000	0.006	0.011	0.017	0.021	0.024	0.024	0.021	0.016	0.011	0.006	0.003	0.000		
	δ_1 (degree)	0.000	0.028	0.069	0.128	0.199	0.267	0.313	0.325	0.300	0.245	0.170	0.087	0.001		
3 Container Ship(Over Panamax)	β_1 (degree)	0.000	0.019	0.036	0.049	0.056	0.059	0.056	0.049	0.040	0.029	0.019	0.009	0.000		
	δ_1 (degree)	0.000	0.082	0.178	0.293	0.425	0.559	0.671	0.736	0.732	0.648	0.485	0.261	0.002		
4 Container(Panamax)	β_1 (degree)	0.000	0.015	0.029	0.038	0.042	0.043	0.040	0.036	0.030	0.023	0.016	0.008	0.000		
	δ_1 (degree)	0.000	0.070	0.143	0.220	0.303	0.387	0.461	0.510	0.517	0.468	0.357	0.195	0.002		
5 Very Large Bulk Carrier	β_1 (degree)	0.000	0.002	0.005	0.008	0.010	0.012	0.012	0.010	0.008	0.005	0.003	0.001	0.000		
	δ_1 (degree)	0.000	0.015	0.039	0.077	0.124	0.169	0.199	0.206	0.189	0.153	0.105	0.053	0.000		
6 Large Bulk Carrier(Panamax)	β_1 (degree)	0.000	0.002	0.004	0.006	0.008	0.009	0.009	0.008	0.006	0.004	0.002	0.001	0.000		
	δ_1 (degree)	0.000	0.015	0.036	0.067	0.104	0.139	0.162	0.167	0.153	0.124	0.085	0.043	0.000		
7 Small Bulk Carrier	β_1 (degree)	0.000	0.006	0.012	0.018	0.024	0.027	0.026	0.023	0.018	0.012	0.006	0.003	0.000		
	δ_1 (degree)	0.000	0.027	0.070	0.135	0.217	0.296	0.351	0.367	0.340	0.278	0.194	0.099	0.001		
8 VLCC	β_1 (degree)	0.000	0.002	0.005	0.008	0.011	0.013	0.013	0.011	0.008	0.005	0.002	0.001	0.000		
	δ_1 (degree)	0.000	0.008	0.027	0.059	0.102	0.143	0.170	0.174	0.157	0.123	0.082	0.040	0.000		
9 Small Tanker	β_1 (degree)	0.000	0.003	0.007	0.011	0.014	0.017	0.017	0.015	0.011	0.007	0.003	0.001	0.000		
	δ_1 (degree)	0.000	0.015	0.044	0.095	0.160	0.223	0.264	0.272	0.245	0.193	0.129	0.064	0.001		
10 Large Pure Car Carrier	β_1 (degree)	0.000	0.041	0.076	0.103	0.118	0.122	0.115	0.100	0.080	0.059	0.038	0.019	0.000		
	δ_1 (degree)	0.000	0.159	0.340	0.556	0.806	1.067	1.298	1.450	1.470	1.324	1.006	0.546	0.005		
11 Pure Car Carrier	β_1 (degree)	0.000	0.051	0.097	0.132	0.152	0.158	0.149	0.130	0.104	0.076	0.048	0.024	0.000		
	δ_1 (degree)	0.000	0.161	0.353	0.593	0.877	1.176	1.440	1.609	1.626	1.458	1.104	0.598	0.006		
12 LNG Ship	β_1 (degree)	0.000	0.033	0.063	0.087	0.103	0.109	0.105	0.091	0.072	0.052	0.032	0.015	0.000		
	δ_1 (degree)	0.000	0.092	0.211	0.374	0.573	0.780	0.952	1.049	1.040	0.914	0.680	0.364	0.003		
13 Refrigerated Cargo Carrier	β_1 (degree)	0.000	0.008	0.015	0.023	0.028	0.032	0.031	0.028	0.022	0.015	0.008	0.004	0.000		
	δ_1 (degree)	0.000	0.036	0.089	0.164	0.255	0.342	0.405	0.425	0.397	0.328	0.231	0.119	0.001		
14 Passenger Ship(2shafts 2propellers)	β_1 (degree)	0.000	0.008	0.015	0.023	0.028	0.032	0.031	0.028	0.022	0.015	0.008	0.004	0.000		
	δ_1 (degree)	0.000	0.174	0.363	0.578	0.826	1.097	1.361	1.561	1.629	1.507	1.169	0.643	0.006		
15 Ferry Boat(2shafts 1propellers)	β_1 (degree)	0.000	0.053	0.100	0.136	0.158	0.164	0.155	0.135	0.108	0.078	0.050	0.024	0.000		
	δ_1 (degree)	0.000	0.113	0.253	0.438	0.662	0.900	1.111	1.244	1.257	1.126	0.851	0.460	0.004		

β_1 : Drift Angle (degree)
 δ_1 : Check Helm (degree)

Table G2-2: Drift Angle β_1 and its corresponding check helm δ_1

For the concept design use, the drift angle β_1 and its corresponding check helm δ_1 may practically and easily be estimated by employing figures of the similar ship to the design ship given in Table G2-2. It is noted that the figures in Table G2-2 are computed for the case of $K = 1.0$, where K is defined as:

$$K = V_{WR}/V_s \quad (G2-0)$$

where V_{WR} and V_s denote the relative wind speed and the ship speed respectively.

For an arbitrary value of K , the drift angle due to the wind forces $\beta_1(K)$ and its corresponding check helm $\delta_1(K)$ can be obtained by the following equations, where the figure given in Table G2-2 for $K = 1.0$ is used:

$$\beta_1(K) = K^2 \times \beta \quad (G2-0)$$

$$\delta_1(K) = K^2 \times \delta \quad (G2-0)$$

In the above drift angle estimation, it should be confirmed that the check helm δ_1 corresponding to each drift angle β_1 be less than the maximum rudder angle ($\delta_R = 35$ deg for the conventional rudder), because the ship handling cannot be made in the case of the rudder angle greater than the maximum one.

In addition to the above type-ship method, when the principal dimensions of the design ship are known, more accurate estimations of the drift angle β_1 and the check helm δ_1 can be made by the direct calculation presented in Section G2.8. As can be seen in Eqs. G2-27 and G2-28, estimations of β_1 and δ_1 may relatively easily be made also in this direct manner by the arithmetic computations without computers.

G2.3.1.2 Drift Angle due to Current Forces

The drift angle due to the current forces β_2 can be obtained by:

$$\beta_2 = \arctan(V_{WR}/V_s) \quad (G2-0)$$

where U_C : current speed perpendicular to channel centre line and U : ship speed.

G2.3.2 Width Requisite against Yawing Motion

Width requisite against the yawing motion caused by unsteady external forces W_{YM} may be defined as the maximum deviation (double amplitude) due to the yawing as shown in Figure G2-2 and W_{YM} may be calculated by the following equation:

$$W_{YM} \left(= 2V_s \int_{t=0}^{t=\frac{T_y}{4}} \sin \psi(t) dt \right) = \frac{1}{2} V_s T_y \sin \psi_0 \quad (G2-0)$$

where the yaw angle is given as:

$$\psi(t) = \psi_0 \sin \left(\frac{2\pi}{T_y} t \right)$$

In Eq. G2-10, T_y (yawing period) = 12 sec. and ψ_0 (the yawing amplitude) = 4 deg may empirically be employed in the computation.

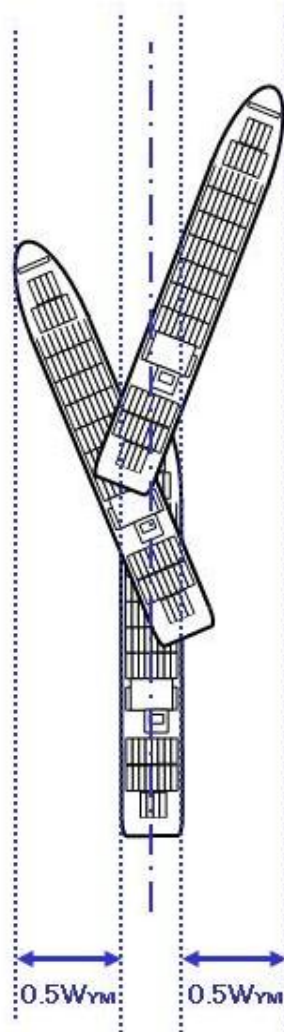

Figure G2-2: W_{YM} : Width requisite against yawing motion

G2.3.3 Width Requisite for Drift Detection

In general, a ship sailing in the fairway more or less makes some amount of lateral deviation from its course line even if the ship handler does believe that his ship is running on the right course line. This drift may hardly be detected within small amount of deviation. However, the ship handler can recognise the drift when the lateral deviation from the fairway centre line becomes considerable amount as shown in Figure G2-3. The drift detection should be considered with respect to both sides of the fairway centre line. Estimations of the width requisite for the drift detection are provided for the following three types of on-board navigation equipments, which are currently available in the actual ship operation.

- Drift detection by observing light buoys with naked eyes
- Drift detection by observing light buoys with RADAR
- Drift detection by GPS or DGPS

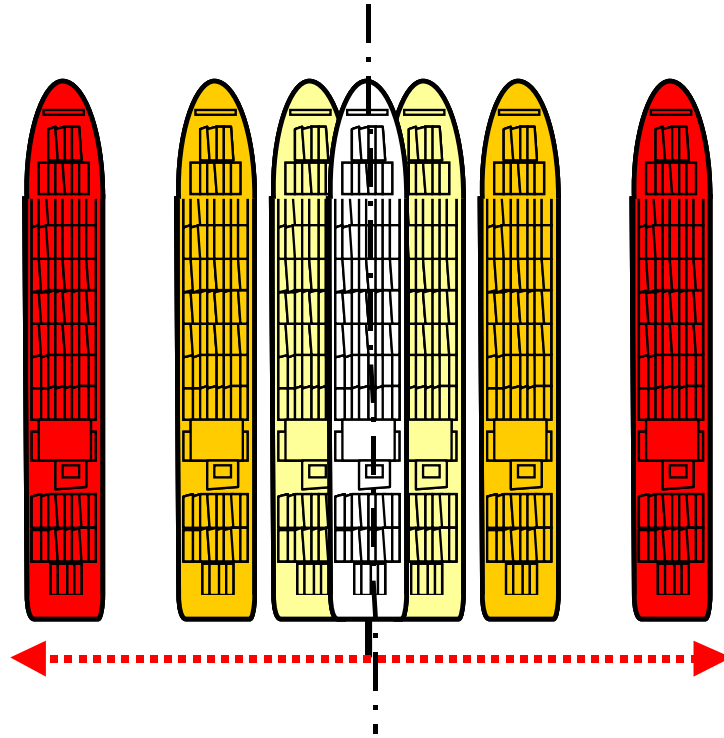

Figure G2-3: Width requisite for drift detection

G2.3.3.1 Drift Detection by Observing Light Buoys with Naked Eye

The width requisite for the drift detection in this case $W_{DD}(NEY)$ may be defined as the maximum deviation that almost all ship handlers are supposed to be able to recognise the drift from the course line by observing light buoys ahead on both sides of the fairway with naked eyes. Referring to Figure G2-4, $W_{DD}(NEY)$ can be calculated by:

$$W_{DD}(NEY) = 2L_F \tan \alpha_{\max} \quad (G2-0)$$

where L_F denotes the distance for the drift detection between the ship and the light buoys ahead along the fairway centre line, and $L_F = 7 \times L_{oa}$ for one-fairway or $L_F = 3.5$ to $7 \times L_{oa}$ for two-way fairway (L_{oa} : the overall length of ship) may empirically be employed in the computation. The maximum intersecting angle corresponding to the above maximum deviation α_{\max} may be estimated with the use of empirical formula developed on the basis of statistical data by full scale experiments and it is given by:

$$\alpha_{\max} = 0.00176\theta^2 + 0.0008\theta + 2.21372 \quad (G2-0)$$

In Eq. G2-12, θ denotes the intersecting angle by two lines from the ship to the two buoys ahead on both sides of the fairway as shown in Figure G2-4 and it is defined as:

$$\theta = 2 \arctan \left(\frac{W_{BUOY}}{2L_F} \right) \quad (G2-0)$$

where W_{Buoy} : clearance between two buoys.

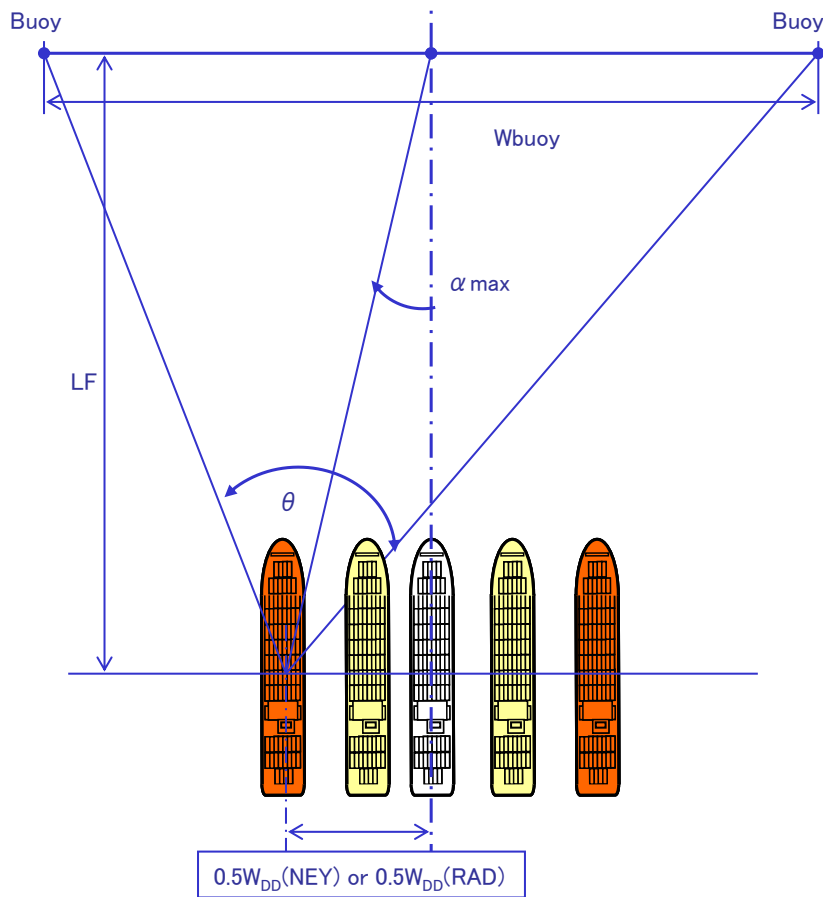

Figure G2-4: Drift detection by observing light buoys with naked eye or RADAR

G2.3.1.2 Drift Detection by Observing Light Buoys with RADAR

The width requisite for the drift detection in this case $W_{DD}(RAD)$ may be calculated by the following equation:

$$W_{DD}(RAD) = 2 \frac{W_{BUOY}}{\sin \theta} \sin \gamma \quad (G2-0)$$

where γ denotes the observation error of direction by RADAR, and Eq. G2-14 is rewritten for the two cases of $\gamma = 2$ deg and $\gamma = 1$ deg as:

$$W_{DD}(RAD) = 0.0698 \frac{W_{BUOY}}{\sin \theta} \quad \gamma = 2 \text{ deg} \quad (G2-0)$$

$$W_{DD}(RAD) = 0.0349 \frac{W_{BUOY}}{\sin \theta} \quad \gamma = 1 \text{ deg} \quad (G2-0)$$

G2.3.1.3 Drift Detection by GPS

It is assumed that the perception error of GPS information on the display by naked eyes be a half of the ship breadth and, in addition, that the error of GPS information itself be 30 meter for the usual GPS and none for the DGPS. Then the following equations may be

given with respect to the width requisite for the drift detections by GPS and DGPS respectively, where the errors are considered for both sides of the fairway centre line (in meters) as:

$$W_{DD}(GPS) = B + 60 \quad (G2-0)$$

$$W_{DD}(DGPS) = B \quad (G2-0)$$

G2.4 Estimation of Additional Width for Interaction Forces

The width requisite against the interaction forces may be estimated with the use of a concept of the requisite clearance between the ship and bank wall or between two ships, in which the ship can keep a straight course line against the interaction forces with the rudder angle predetermined from a view point of the actual ship operation. Making use of the check helm calculation presented in Section G2.9, the requisite clearance may be obtained in the following manner. Namely check helm computations are made first for some values of the clearance between the ship and bank wall or between ships and then the requisite clearance can be obtained by determining the clearance corresponding to the predetermined rudder angle through interpolations.

G2.4.1 Width Requisite against Bank Effect Forces

Table G2-3 gives the requisite clearance with respect to the bank effect forces for the 15 ships, which are obtained with the predetermined $\delta_R = 5$ deg. In Table G2-3 together with Figure G2-5, the requisite clearance is denoted by the term of 'bank clearance' with a symbol of W_{bio} . It is noted that the figures of bank clearance are obtained for the canal section with the upright wall.

No.	Ship Type	L_{pp}	B	W_{bio}	W_{bio}/B
1	Cargo ship	103.0	20.0	17.4	0.87
2	Small cargo ship	60.4	11.2	9.8	0.87
3	Container ship (OVER PANAMAX)	283.8	40.0	55.5	1.39
4	Container (PANAMAX)	273.0	32.2	55.2	1.71
5	Very large bulk carrier	279.0	45.0	52.6	1.17
6	Large bulk carrier (PANAMAX)	216.0	32.3	41.9	1.30
7	Small bulk carrier	119.2	21.5	20.3	0.95
8	VLCC	316.0	60.0	49.7	0.83
9	Small tanker	92.0	20.0	13.8	0.69
10	Large pure car carrier	190.0	32.2	34.3	1.06
11	Pure car carrier	180.0	32.2	31.2	0.97
12	LNG ship	270.0	44.8	47.7	1.07
13	Refrigerated cargo carrier	144.0	23.5	26.6	1.13
14	Passenger ship (2 shafts, 2 propellers)	160.0	24.7	25.9	1.05
15	Ferry boat (2 shafts, 1 propellers)	181.0	29.4	30.5	1.04
Units: meters					

Table G2-3: Bank clearance

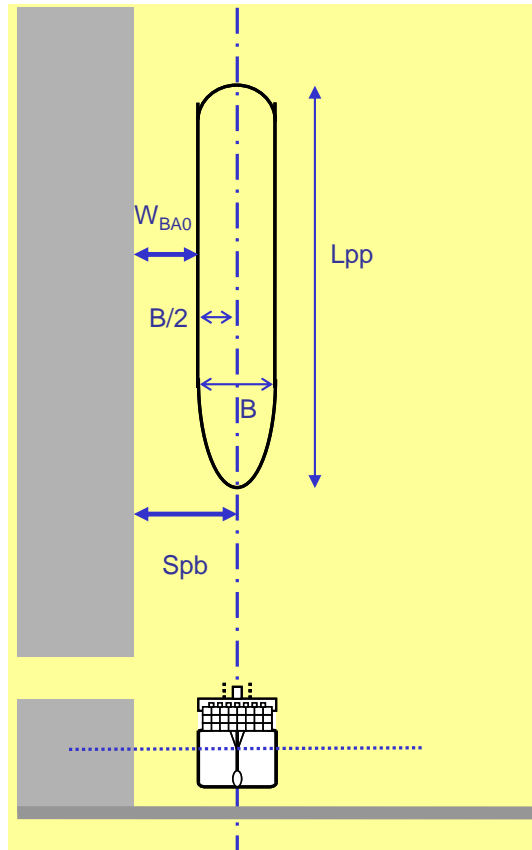

Figure G2-5: Width requisite against bank effect forces

For the practical use at the concept design, the width requisite against the bank effect forces for the canal section W_{BA0} may simply be estimated by assuming a similar ship to the design ship given in Table G2-3 as:

$$W_{BA0} = W_{bi0} \quad (G2-0)$$

Taking the bank effects on both sides of the fairway into consideration, the width for the dredged fairway shown in Figure G2-6 W_{BA} may be obtained by:

$$W_{BA} = (C_{DS}^L + C_{DS}^R) W_{BA0} \quad (G2-0)$$

In the above equation, C_{DS}^L and C_{DS}^R denote corrections of the dredged fairway configuration to the canal section for the left and right side banks respectively and C_{DS} is given by the following equation:

$$C_{DS} = \exp\left(-\frac{2h_1}{1-h_1}\right) \quad (G2-0)$$

where:

$$h_1 = \frac{D_{OUT}^*}{D} = \frac{1}{2} \frac{D + D_{OUT}}{D}$$

D_{OUT} : water depth of outer fairway,

D: water depth of inner fairway.

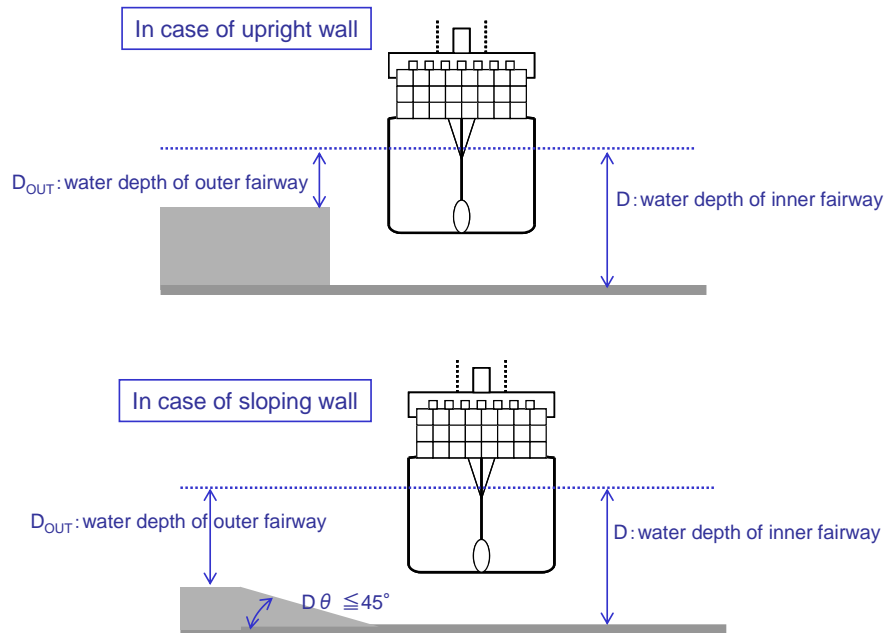

Figure G2-6: Width for the dredged fairway

G2.4.2 Width Requisite against Two-Ship Interaction in Passing

Table G2-4 shows the requisite clearance with respect to the two-ship interaction in the passing for the 15 ships, which are obtained with the predetermined $\delta_R = 15$ deg. In Table G2-4 together with Figure G2-7, the requisite clearance is denoted by the term of 'passing distance' with a symbol of W_c . For the practical design use, the width requisite against the two-ship interaction in passing W_{PA} may easily be estimated assuming a similar ship to the design ship given in Table G2-4 as:

$$W_{PA} = W_c \quad (G2-0)$$

No.	Ship Type	L_{pp}	B	W_c	W_c/B
1	Cargo ship	103.0	20.0	32.6	1.63
2	Small cargo ship	60.4	11.2	17.6	1.57
3	Container ship (OVER PANAMAX)	283.8	40.0	105.0	2.63
4	Container (PANAMAX)	273.0	32.2	103.6	3.22
5	Very large bulk carrier	279.0	45.0	98.8	2.20
6	Large bulk carrier (PANAMAX)	216.0	32.3	79.0	2.45
7	Small bulk carrier	119.2	21.5	38.2	1.77
8	VLCC	316.0	60.0	91.0	1.52
9	Small tanker	92.0	20.0	25.2	1.26
10	Large pure car carrier	190.0	32.2	64.6	2.01
11	Pure car carrier	180.0	32.2	58.4	1.81
12	LNG ship	270.0	44.8	90.7	2.03
13	Refrigerated cargo carrier	144.0	23.5	50.5	2.15
14	Passenger ship (2 shafts, 2 propellers)	160.0	24.7	47.7	1.93
15	Ferry boat (2 shafts, 1 propellers)	181.0	29.4	57.1	1.94
Units: meters					

Table G2-4: Passing distance

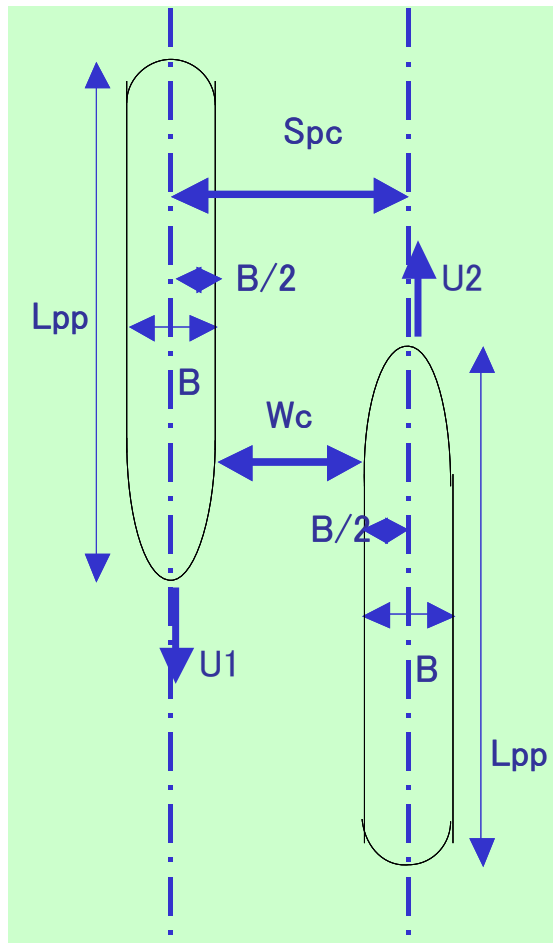

Figure G2-7: Width requisite against two-ship interaction in passing

G2.4.3 Width Requisite against Two-Ship Interaction in Overtaking

In the same way as the above, Table G2-5 shows the requisite clearance with respect to the two-ship interaction in the overtaking for the 15 ships, which are obtained with the predetermined $\delta_R = 15$ deg. In Table G2-5 together with Figure G2-8, the requisite clearance is denoted by the term of 'overtaking distance' with a symbol of W_{ov} . Both Figure 3.2 of Chapter 3 of the main text and this Figure G2.8 are based on the same fundamental concept. In order to calculate the W_p in the Figure 3.2 of Chapter 3 of the main text, we selected the closest W_p to various W_M . For the practical design use, the width requisite against the two-ship interaction in the overtaking W_{ov} may easily be estimated assuming a similar ship to the design ship given in Table G2-5 as:

$$W_{OV} = W_{ov} \quad (G2-0)$$

In addition to the above type-ship method, in the similar way to the drift angle due to the wind forces given in Section G2.3, when the principal dimensions of the design ship are known, more accurate estimations of the width requisite against the interaction forces may be made by the direct application of the check helm calculation presented in Section G2.9.

No.	Ship Type	L_{pp}	B	W_{ov}	W_{ov}/B
1	Cargo ship	103.0	20.0	55.7	2.79
2	Small cargo ship	60.4	11.2	30.0	2.68
3	Container ship (OVER PANAMAX)	283.8	40.0	169.1	4.23
4	Container (PANAMAX)	273.0	32.2	163.2	5.07
5	Very large bulk carrier	279.0	45.0	162.2	3.60
6	Large bulk carrier (PANAMAX)	216.0	32.3	128.4	3.98
7	Small bulk carrier	119.2	21.5	64.2	2.98
8	VLCC	316.0	60.0	155.7	2.60
9	Small tanker	92.0	20.0	44.9	2.24
10	Large pure car carrier	190.0	32.2	106.9	3.32
11	Pure car carrier	180.0	32.2	98.2	3.05
12	LNG ship	270.0	44.8	150.1	3.35
13	Refrigerated cargo carrier	144.0	23.5	83.2	3.54
14	Passenger ship (2 shafts, 2 propellers)	160.0	24.7	78.3	3.17
15	Ferry boat (2 shafts, 1 propellers)	181.0	29.4	94.7	3.22

Units: meters

Table G2-5: Overtaking distance

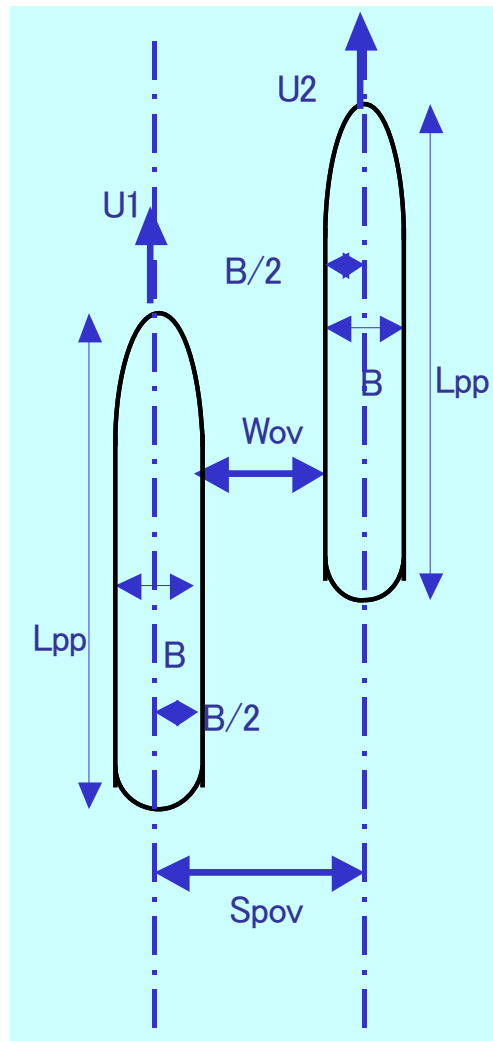

Figure G2-8: Width requisite against two-ship interaction in overtaking

G2.5 Safety Factor Based on Risk Level

The safety factor C_{SF} may be determined on the basis of the risk level concept. Three stages of risk levels (low, medium and high levels) are ranked taking four kinds of risk factors (ship speed, cargo kind, traffic density and uncertain element) into consideration. The risk levels are quantified by the points which may evaluate the significance of risk corresponding to each risk factor. The evaluation points are given in Table G2-6 as functions of the risk level and risk factor. As shown in Table G2-6, the risk levels for the traffic density are specified in terms of the ship-ship interval and the values of ship-ship interval are given referring to the Bumper model for the medium risk level and to the investigation by MARIN et al. (2005) for the high risk level. The total evaluation point is obtained by summing up each evaluation point for each risk factor. Finally, the safety factor can be determined with use of figures in Table G2-7 on the basis of the total evaluation point.

Risk Factor		Risk Level		
		Low	Medium	High
1	U (Ship Speed)	$U < 7.5 \text{ knot}$	$7.5 \text{ knot} \leq U < 12.5 \text{ knot}$	$12.5 \text{ knot} \leq U$
		0	0	1
2	Cargo Type	Bulk	Passengers	Oil
		General Cargo	LPG
		Containeres		LNG
			Chemicals
			
		0	1	3
3	Traffic Density (SI: Ship Interval)	$10Loa \leq SI$	$6Loa \leq SI < 10Loa$	$4Loa \leq SI < 6Loa$
		0	2	5
4	Uncertain Element	0	1	3

Table G2-6: Risk evaluation point with risk level and risk factor

Total of Risk Evaluation Point	C_{SF}
0~2	1.0
3~6	1.1
7~9	1.2
10~12	1.3

Table G2-7: Safety factor by risk evaluation point

G2.6 Fairway Width Determination

G2.6.1 Determination Procedures

The total fairway width can be determined by the basic formulae described in Section G2.1. However it is noted that $W_{DD}(NEY)$ in Eq. G2-11 and $W_{DD}(RAD)$ in Eq. G2-14 are given as functions of W_{Buoy} (the clearance between two buoys ahead on both sides) which should be identical to the design target of the fairway width. For this reason, iteration computations are needed for the cases of the drift detection by observing light buoys either with the naked eye or with RADAR and the iteration procedure is briefly given as follows. Assuming some amount of W_{Buoy} and substituting it into Eq. G2-11 or Eq. G2-14, then $W_{DD}(NEY)$ or $W_{DD}(RAD)$ are computed, where the computed $(W_{BM} + W_{IF})$ by Eq.

G2-2 and G2-3 should be identical to the assumed W_{Buoy} . Some steps of iterations, not one-time computation but some few steps or more, may usually be needed in order to attain a satisfactory convergence for the difference between the assumed W_{Buoy} and the computed $(W_{BM} + W_{IF})$. The convergence may be judged by:

$$|\text{assumed } W_{BUOY} - \text{computed } (W_{BM} + W_{IF})| < \varepsilon \quad (\text{G2-0})$$

where $\varepsilon = 1.0$ metre may be taken. In addition, regarding the assumption of W_{Buoy} at the first step computation, quick convergent iteration may be expected by employing a value of L_{oa} for the one-way channel and $2 L_{oa}$ for the two-way channel.

Regarding the drift detection by GPS or DGPS, the total fairway width can easily be determined simply by summing up the necessary elements given in Eqs. G2-1 to G2-3.

G2.6.2 Design Examples

Typical design examples are shown in Table G2-8 to Table G2-11, in which the process of fairway width determination is given in detail in the form of spreadsheet for the designer-friendly use. The fairway width designs are made for the following three typical ship types supposing the ship speed of 10.0 knots, the cross wind with speed of 10.0 m/s and the shallow water of $h/T = 1.2$.

- Container Ship: $L_{oa} \times L_{pp} \times B \times T = 288.3 \text{ m} \times 273.0 \text{ m} \times 32.2 \text{ m} \times 13.3 \text{ m}$
- VLCC: $L_{oa} \times L_{pp} \times B \times T = 333.0 \text{ m} \times 316.0 \text{ m} \times 60.0 \text{ m} \times 20.4 \text{ m}$
- LNGC: $L_{oa} \times L_{pp} \times B \times T = 283.0 \text{ m} \times 270.0 \text{ m} \times 44.8 \text{ m} \times 10.8 \text{ m}$

Table G2-8 and Table G2-9 give the fairway width determination for the case of dredged fairway with bank effects with respect to the drift detection by RADAR (the average values of observation error of 1 and 2 deg) and naked eye respectively. Meanwhile, Table G2-10 and Table G2-11 give the fairway width determination for the case of open fairway in the cross-current with speed of 1.0 kt with respect to the drift detection by RADAR and naked eye respectively. Upper half of Tables shows the resulting value of each elements that calculated by the above formulae.

Furthermore, in order to easily understand the design procedures in the Japanese calculation method, more detailed computations are given in the lower half of Table G2-8 and Table G2-9 (for the container ship) showing each step of iterations to reach the final width determination.

[Navigational Environments]

Ship Speed	10.0 knot	
Cross Wind	10.0 m/s	(90°)
Cross Current	0.0 knot	(90°)
By Rader 2°		

[Sectional Condition]

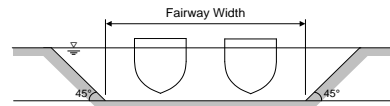

Two-Way	Ship Type						
	Container	VLCC	LNG				
Loa	288.3m	333.0m	283.0m				
Lpd	273.0m	316.0m	270.0m				
B	32.2m	60.0m	44.8m				
T	13.3m	20.4m	10.8m				
$W_{TOTAL_for_risk} = (W_{BM} + W_{IF}) C_{SF} ※1$	333.7m	10.4B	436.6m	7.3B	378.4m	8.4B	
$W_{TOTAL} = (W_{BM} + W_{IF})$	333.7m	10.4B	396.9m	6.6B	344.0m	7.7B	
W_{BM}	$W_{WF} + W_{CF}$	33.0m	1.0B	60.3m	1.0B	46.8m	1.0B
	W_{YM}	2.2m	0.1B	2.2m	0.0B	2.2m	0.0B
	W_{DD}	72.4m	2.2B	83.8m	1.4B	71.2m	1.6B
	$W_{WF} + W_{CF} + W_{YM} + W_{DD}$	107.5m	3.3B	146.2m	2.4B	120.1m	2.7B
$W_{BM} = a(W_{WF} + W_{CF} + W_{YM} + W_{DD}) ※2$	a	2	2	2	2	2	
		215.1m	6.7B	292.5m	4.9B	240.2m	5.4B
W_{IF}	W_{BA}	15.0m	0.5B	13.4m	0.2B	13.0m	0.3B
	W_{PA}	103.6m	3.2B	91.1m	1.5B	90.7m	2.0B
	b	1	1	1	1	1	
	W_{OV}	163.2m	5.1B	155.7m	2.6B	150.1m	3.3B
	c	0	0	0	0	0	
$W_{IF} = W_{BA} + bW_{PA} + cW_{OV} ※3$	118.6m	3.7B	104.5m	1.7B	103.7m	2.3B	
C_{SF}	1.0	1.1	1.1	1.1	1.1	1.1	

Risk Factor	Container	VLCC	LNG
1. U (Ship Speed)	0	0	0
2. Cargo Type	0	3	3
3. Traffic Density	0	0	0
4. Uncertain Element	1	1	1
Total Evaluation Points	1	4	4
C_{SF}	1.0	1.1	1.1

Appendix[F] ※1:Eq.(1.1) ※2:Eq.(1.2) ※3:Eq.(1.3)

Concrete Calculation Method

Calculation Object	[CONTAINER]
Ship Speed (=U)	10.0 knot (5.14m/s)
Cross Wind (=Uw)	10.0 m/s (90°)
Cross Current	0.0 knot (90°)

STEP 1 [Calculation of Element except for W_{DD}]

$K=Uw/U$ ←Eq.3.3	1.95	(=10/5.14)
$\beta 1(K)$ ←Table3.1 and Eq3.4	0.15°	(=1.95² * 0.040)
$\beta 2$ ←Eq3.6	0°	(=arctan(0/10knot))
$\beta = \beta 1 + \beta 2$ ←Eq3.2	0.15°	(=0.15+0.00)
$W_{WF} + W_{CF}$ ←Eq3.1	32.97 m	(=273.0*sin0.15° + 32.2*cos0.15°)
W_{YM} ←Eq3.7	2.2 m	(Ty=12sec $\Psi_0=4$ degree)
W_{BA} ←Table4.1 Eq4.2	15 m	(=0.1353+0.1353)*55.2
W_{PA} ←Table4.2	103.6 m	
W_{OV} ←Table4.3	163.2 m	

STEP 2 [Convergent Iteration for W_{TOTAL}]

1st	assumed $W_{BUOY}[1]$	432.5 m	(=1.5Loa : Dummy Value)
	θ ←Eq3.10	24.2°	(LF=3.5Loa)
	$W_{DD}(RAD)$ ←Eq3.8	73.7 m	
	W_{BM} ←Eq1.2	217.7 m	(=2.0*($W_{WF} + W_{CF} + W_{YM} + W_{DD}$))
	W_{IF} ←Eq1.3	118.6 m	(= $W_{BA} + W_{PA}$)
	W_{TOTAL}	336.3 m	(= $W_{BM} + W_{IF}$)
	assumed $W_{BUOY}[1] - W_{TOTAL}$	96.2 m	> 1 → No! → Recomputation
2nd	assumed $W_{BUOY}[2]$	336.3 m	
	θ ←Eq3.10	18.9°	(LF=3.5Loa)
	$W_{DD}(RAD)$ ←Eq3.8	72.4 m	
	W_{BM} ←Eq1.2	215.1 m	(=2.0*($W_{WF} + W_{CF} + W_{YM} + W_{DD}$))
	W_{IF} ←Eq1.3	118.6 m	(= $W_{BA} + W_{PA}$)
	W_{TOTAL}	333.7 m	(= $W_{BM} + W_{IF}$)
	assumed $W_{BUOY}[1] - W_{TOTAL}$	2.6 m	> 1 → No! → Recomputation
3rd	assumed $W_{BUOY}[3]$	333.7 m	
	θ ←Eq3.10	18.8°	(LF=3.5Loa)
	$W_{DD}(RAD)$ ←Eq3.8	72.4 m	
	W_{BM} ←Eq1.2	215.1 m	(=2.0*($W_{WF} + W_{CF} + W_{YM} + W_{DD}$))
	W_{IF} ←Eq1.3	118.6 m	(= $W_{BA} + W_{PA}$)
	W_{TOTAL}	333.7 m	(= $W_{BM} + W_{IF}$)
	assumed $W_{BUOY}[1] - W_{TOTAL}$	0.06 m	<< 1 → Good

*** FINAL ANSWER ! ***

W_{BM}	$W_{WF} + W_{CF}$	33.0 m
	W_{YM}	2.20 m
	W_{DD}	72.4 m
$W_{BM} = 2.0 * (W_{WF} + W_{CF} + W_{YM} + W_{DD})$		215.1 m
W_{IF}	W_{BA}	15.0 m
	W_{PA}	103.6 m
$W_{IF} = W_{BA} + 1.0 * W_{PA}$		118.6 m
$W_{TOTAL} = (W_{BM} + W_{IF})$		333.7 m

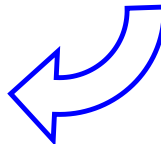
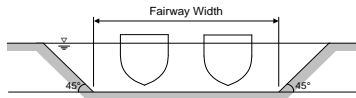

Table G2-8: Example of fairway width determination (drift detection by RADAR with bank effects)

Navigation Environment

Ship Speed	10.0 knot	(90°)
Cross Wind	10.0 m/s	(90°)
Cross Current	0.0 knot	(90°)
By Eyes		

Sectional Condition



Two-Way	Ship Type			
	Container	VLCC	LNG	
Loa	288.3m	333.0m	283.0m	
Lpp	273.0m	316.0m	270.0m	
B	32.2m	60.0m	44.8m	
T	13.3m	20.4m	10.8m	
$W_{TOTAL-for\ risk} = (W_{BM} + W_{IF}) C_{SF} \times 1$	412.7m	542.2m	471.6m	
$W_{TOTAL} = (W_{BM} + W_{IF})$	412.7m	492.9m	428.8m	
W_{BM}	$W_{WF} + W_{CF}$	33.0m	60.3m	46.8m
	W_{YM}	2.2m	2.2m	0.0m
	W_{DD}	111.9m	131.8m	113.6m
	$W_{WF} + W_{CF} + W_{YM} + W_{DD}$	147.1m	194.2m	162.5m
	a	2	2	2
W_{IF}	W_{BA}	15.0m	13.4m	13.0m
	W_{PA}	103.6m	91.1m	90.7m
	b	1	1	1
	W_{OV}	163.2m	155.7m	150.1m
	c	0	0	0
$W_{IF} = W_{BA} + W_{PA} + W_{OV} \times 3$	118.60m	104.5m	103.7m	
C_{SF}	1.0	1.1	1.1	

Risk Factor	Container	VLCC	LNG
1. U (Ship Speed)	0	0	0
2. Cargo Type	0	3	3
3. Traffic Density	0	0	0
4. Uncertain Element	1	1	1
Total Evaluation Points	1	4	4
C_{SF}	1.0	1.1	1.1

Appendix[F] ※1: Eq.(1.1) ※2: Eq.(1.2) ※3: Eq.(1.3)

Concrete Calculation Method

Calculation Object	[CONTAINER]
Ship Speed (=U)	10.0 knot (5.14m/s)
Cross Wind (=Uw)	10.0 m/s (90°)
Cross Current	0.0 knot (90°)

STEP 1 [Calculation of Element except for W_{DD}]

$K=Uw/U$ ←Eq.3.3	1.95	(=10/5.14)
$\beta_1(K)$ ←Table3.1 and Eq3.4	0.15°	(=1.95° * 0.040)
β_2 ←Eq3.6	0°	(=arctan(0/10knot))
$\beta = \beta_1 + \beta_2$ ←Eq3.2	0.15°	(=0.15+0.0)
$W_{WF} + W_{CF}$ ←Eq3.1	32.97 m	(=273.0 * sin(0.15°) + 32.2 * cos(0.15°))
W_{YM} ←Eq3.7	2.2 m	(Ty=12sec $\Psi_0=4$ degree)
W_{BA} ←Table4.1 Eq4.2	15 m	(=0.1353+0.1353)*55.2
W_{PA} ←Table4.2	103.6 m	
W_{OV} ←Table4.3	163.2 m	

STEP 2 [Convergent Iteration for W_{TOTAL}]

Iteration	assumed W_{BUOY}	θ	α max	$W_{DD}(NEY)$	W_{BM}	W_{IF}	W_{TOTAL}	assumed W_{BUOY} - W_{TOTAL}
1st	1 [1]	576.6 m	31.9°	4.03°	142.2 m	354.6 m	118.6 m	473.2 m
	←Eq3.10	576.6 m	31.9°	4.03°	142.2 m	354.6 m	118.6 m	473.2 m
	←Eq3.9	576.6 m	31.9°	4.03°	142.2 m	354.6 m	118.6 m	473.2 m
	←Eq3.8	576.6 m	31.9°	4.03°	142.2 m	354.6 m	118.6 m	473.2 m
	←Eq1.2	576.6 m	31.9°	4.03°	142.2 m	354.6 m	118.6 m	473.2 m
	←Eq1.3	576.6 m	31.9°	4.03°	142.2 m	354.6 m	118.6 m	473.2 m
	←Eq1.2	576.6 m	31.9°	4.03°	142.2 m	354.6 m	118.6 m	473.2 m
	←Eq1.3	576.6 m	31.9°	4.03°	142.2 m	354.6 m	118.6 m	473.2 m
2nd	2 [2]	473.3 m	26.4°	3.46°	122.1 m	314.5 m	118.6 m	433.1 m
	←Eq3.10	473.3 m	26.4°	3.46°	122.1 m	314.5 m	118.6 m	433.1 m
	←Eq3.9	473.3 m	26.4°	3.46°	122.1 m	314.5 m	118.6 m	433.1 m
	←Eq3.8	473.3 m	26.4°	3.46°	122.1 m	314.5 m	118.6 m	433.1 m
	←Eq1.2	473.3 m	26.4°	3.46°	122.1 m	314.5 m	118.6 m	433.1 m
	←Eq1.3	473.3 m	26.4°	3.46°	122.1 m	314.5 m	118.6 m	433.1 m
	←Eq1.2	473.3 m	26.4°	3.46°	122.1 m	314.5 m	118.6 m	433.1 m
	←Eq1.3	473.3 m	26.4°	3.46°	122.1 m	314.5 m	118.6 m	433.1 m
3rd	3 [3]	433.1 m	24.2°	3.27°	115.2 m	300.7 m	118.6 m	419.3 m
	←Eq3.10	433.1 m	24.2°	3.27°	115.2 m	300.7 m	118.6 m	419.3 m
	←Eq3.9	433.1 m	24.2°	3.27°	115.2 m	300.7 m	118.6 m	419.3 m
	←Eq3.8	433.1 m	24.2°	3.27°	115.2 m	300.7 m	118.6 m	419.3 m
	←Eq1.2	433.1 m	24.2°	3.27°	115.2 m	300.7 m	118.6 m	419.3 m
	←Eq1.3	433.1 m	24.2°	3.27°	115.2 m	300.7 m	118.6 m	419.3 m
	←Eq1.2	433.1 m	24.2°	3.27°	115.2 m	300.7 m	118.6 m	419.3 m
	←Eq1.3	433.1 m	24.2°	3.27°	115.2 m	300.7 m	118.6 m	419.3 m
4th	4 [4]	419.3 m	23.5°	3.20°	112.9 m	296.2 m	118.6 m	414.8 m
	←Eq3.10	419.3 m	23.5°	3.20°	112.9 m	296.2 m	118.6 m	414.8 m
	←Eq3.9	419.3 m	23.5°	3.20°	112.9 m	296.2 m	118.6 m	414.8 m
	←Eq3.8	419.3 m	23.5°	3.20°	112.9 m	296.2 m	118.6 m	414.8 m
	←Eq1.2	419.3 m	23.5°	3.20°	112.9 m	296.2 m	118.6 m	414.8 m
	←Eq1.3	419.3 m	23.5°	3.20°	112.9 m	296.2 m	118.6 m	414.8 m
	←Eq1.2	419.3 m	23.5°	3.20°	112.9 m	296.2 m	118.6 m	414.8 m
	←Eq1.3	419.3 m	23.5°	3.20°	112.9 m	296.2 m	118.6 m	414.8 m

Iteration	assumed W_{BUOY}	θ	α max	$W_{DD}(NEY)$	W_{BM}	W_{IF}	W_{TOTAL}	assumed W_{BUOY} - W_{TOTAL}
5th	5 [5]	414.8 m	23.2°	3.18°	112.2 m	294.7 m	118.6 m	413.3 m
	←Eq3.10	414.8 m	23.2°	3.18°	112.2 m	294.7 m	118.6 m	413.3 m
	←Eq3.9	414.8 m	23.2°	3.18°	112.2 m	294.7 m	118.6 m	413.3 m
	←Eq3.8	414.8 m	23.2°	3.18°	112.2 m	294.7 m	118.6 m	413.3 m
	←Eq1.2	414.8 m	23.2°	3.18°	112.2 m	294.7 m	118.6 m	413.3 m
	←Eq1.3	414.8 m	23.2°	3.18°	112.2 m	294.7 m	118.6 m	413.3 m
	←Eq1.2	414.8 m	23.2°	3.18°	112.2 m	294.7 m	118.6 m	413.3 m
	←Eq1.3	414.8 m	23.2°	3.18°	112.2 m	294.7 m	118.6 m	413.3 m
6th	6 [6]	413.3 m	23.1°	3.18°	111.9 m	294.2 m	118.6 m	412.8 m
	←Eq3.10	413.3 m	23.1°	3.18°	111.9 m	294.2 m	118.6 m	412.8 m
	←Eq3.9	413.3 m	23.1°	3.18°	111.9 m	294.2 m	118.6 m	412.8 m
	←Eq3.8	413.3 m	23.1°	3.18°	111.9 m	294.2 m	118.6 m	412.8 m
	←Eq1.2	413.3 m	23.1°	3.18°	111.9 m	294.2 m	118.6 m	412.8 m
	←Eq1.3	413.3 m	23.1°	3.18°	111.9 m	294.2 m	118.6 m	412.8 m
	←Eq1.2	413.3 m	23.1°	3.18°	111.9 m	294.2 m	118.6 m	412.8 m
	←Eq1.3	413.3 m	23.1°	3.18°	111.9 m	294.2 m	118.6 m	412.8 m
Final	7 [7]	412.8 m	23.1°	3.17°	111.9 m	294.1 m	118.6 m	412.7 m
	←Eq3.10	412.8 m	23.1°	3.17°	111.9 m	294.1 m	118.6 m	412.7 m
	←Eq3.9	412.8 m	23.1°	3.17°	111.9 m	294.1 m	118.6 m	412.7 m
	←Eq3.8	412.8 m	23.1°	3.17°	111.9 m	294.1 m	118.6 m	412.7 m
	←Eq1.2	412.8 m	23.1°	3.17°	111.9 m	294.1 m	118.6 m	412.7 m
	←Eq1.3	412.8 m	23.1°	3.17°	111.9 m	294.1 m	118.6 m	412.7 m
	←Eq1.2	412.8 m	23.1°	3.17°	111.9 m	294.1 m	118.6 m	412.7 m
	←Eq1.3	412.8 m	23.1°	3.17°	111.9 m	294.1 m	118.6 m	412.7 m

*** FINAL ANSWER ! ***

$W_{WF} + W_{CF}$	33.0 m
W_{YM}	2.20 m
W_{DD}	111.9 m
$W_{BM} = 2.0 * (W_{WF} + W_{CF} + W_{YM} + W_{DD})$	294.1 m
W_{IF}	118.6 m
W_{BA}	15.0 m
W_{PA}	103.6 m
$W_{IF} = W_{BA} + 1.0 * W_{PA}$	118.6 m
$W_{TOTAL} = (W_{BM} + W_{IF})$	412.7 m

Table G2-9: Example of fairway width determination (drift detection by naked eyes with bank effects)

【Navigational Environments】

Ship Speed	10.0 knot
Cross Wind	10.0 m/s (90°)
Cross Current	1.0 knot (90°)
By Rader (avarage 1° and 2°)	

【Sectional Condition】

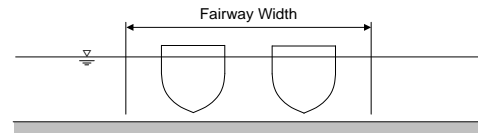

Two-Way	Ship Type						
	Container	VLCC	LNG				
Loa	288.3m	333.0m	283.0m				
Lpp	273.0m	316.0m	270.0m				
B	32.2m	60.0m	44.8m				
d	13.3m	20.4m	10.8m				
$W_{TOTAL} = (W_{BM} + W_{IF}) C_{SF} ※1$	339.9m	10.6B	448.6m	7.5B	386.9m	8.6B	
W_{BM}	$W_{WF} + W_{CF}$	61.5m	1.9B	93.1m	1.6B	74.7m	1.7B
	W_{YM}	2.2m	0.1B	2.2m	0.0B	2.2m	0.0B
	W_{DD}	54.5m	1.7B	63.1m	1.1B	53.7m	1.2B
	$W_{WF} + W_{CF} + W_{YM} + W_{DD}$	118.1m	3.7B	158.4m	2.6B	130.5m	2.9B
a	2		2		2		
$W_{BM} = a(W_{WF} + W_{CF} + W_{YM} + W_{DD}) ※2$	236.3m	7.3B	316.7m	5.3B	261.0m	5.8B	
W_{IF}	W_{BA}	0.0m	0.0B	0.0m	0.0B	0.0m	0.0B
	W_{PA}	103.6m	3.2B	91.1m	1.5B	90.7m	2.0B
	b	1		1		1	
	W_{OV}	163.2m	5.1B	155.7m	2.6B	150.1m	3.3B
c	0		0		0		
$W_{IF} = W_{BA} + bW_{PA} + cW_{OV} ※3$	103.6m	3.2B	91.1m	1.5B	90.7m	2.0B	
C_{SF}	1.0		1.1		1.1		

Risk Factor	Container	VLCC	LNG
1. U (Ship Speed)	0	0	0
2. Cargo Type	0	3	3
3. Traffic Density	0	0	0
4. Uncertain Element	1	1	1
Total Evaluation Points	1	4	4
C_{SF}	1.0	1.1	1.1

Appendix[F] ※1:Eq.(1.1) ※2:Eq.(1.2) ※3:Eq.(1.3)

Table G2-10: Example of fairway width determination (drift detection by RADAR with cross-current)

【Navigational Environments】

Ship Speed	10.0 knot
Cross Wind	10.0 m/s (90°)
Cross Current	1.0 knot (90°)
By Eyes	

【Sectional Condition】

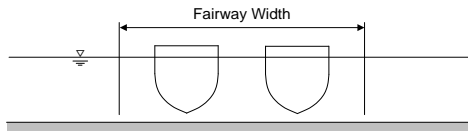

Two-Way	Ship Type						
	Container	VLCC	LNG				
Loa	288.3m	333.0m	283.0m				
Lpp	273.0m	316.0m	270.0m				
B	32.2m	60.0m	44.8m				
d	13.3m	20.4m	10.8m				
$W_{TOTAL} = (W_{BM} + W_{IF}) C_{SF} ※1$	476.1m	14.8B	630.5m	10.5B	544.7m	12.2B	
W_{BM}	$W_{WF} + W_{CF}$	61.5m	1.9B	93.1m	1.6B	74.7m	1.7B
	W_{YM}	2.2m	0.1B	2.2m	0.0B	2.2m	0.0B
	W_{DD}	122.6m	3.8B	145.8m	2.4B	125.4m	2.8B
	$W_{WF} + W_{CF} + W_{YM} + W_{DD}$	186.2m	5.8B	241.1m	4.0B	202.2m	4.5B
a	2		2		2		
$W_{BM} = a(W_{WF} + W_{CF} + W_{YM} + W_{DD}) ※2$	372.5m	11.6B	482.1m	8.0B	404.4m	9.0B	
W_{IF}	W_{BA}	0.0m	0.0B	0.0m	0.0B	0.0m	0.0B
	W_{PA}	103.6m	3.2B	91.1m	1.5B	90.7m	2.0B
	b	1		1		1	
	W_{OV}	163.2m	5.1B	155.7m	2.6B	150.1m	3.3B
c	0		0		0		
$W_{IF} = W_{BA} + bW_{PA} + cW_{OV} ※3$	103.6m	3.2B	91.1m	1.5B	90.7m	2.0B	
C_{SF}	1.0		1.1		1.1		

Risk Factor	Container	VLCC	LNG
1. U (Ship Speed)	0	0	0
2. Cargo Type	0	3	3
3. Traffic Density	0	0	0
4. Uncertain Element	1	1	1
Total Evaluation Points	1	4	4
C_{SF}	1.0	1.1	1.1

Appendix[F] ※1:Eq.(1.1) ※2:Eq.(1.2) ※3:Eq.(1.3)

Table G2-11: Example of fairway width determination (drift detection by naked eye with cross-current)

G2.7 Bend Curvature Determination

The curvature of bend which joins two straight line channel legs should be determined by considering both aspects of the ship turning ability and the rudder angle to be taken and the bend radius R (= the ship turning radius R_c) may be calculated by the following equation:

$$R = L_{oa} / (K_R \delta_R) \quad (G2-0)$$

where:

L_{oa} : length of ship (between perpendiculars)

K_R : non-dimensional index of turning ability

δ_R : rudder angle.

Table G2-12 gives the non-dimensional index of the turning ability K_R for the 13 ships, which are obtained by analysing the motion trajectories of 90 deg turning computed with the use of fully nonlinear equations of the ship manoeuvring motion [MARIN, 2005 ; Inoue et al., 1981]. The computations are made for the tuning motion with $\delta_R = 20$ deg in the shallow water of $h/T = 1.2$ under non-external forces.

For the concept design use, the turning ability index K_R may practically and easily be estimated by assuming a similar ship to the design ship given in Table G2-12 as:

$$K_R = K' \quad (G2-0)$$

It is noted that K' are not given for the 2 types of PCCs in Table G2-12, for which careful attentions and considerations should be paid in the detailed way from a view point of the large wind force effects.

	Ship Type	K'
1	Cargo Ship	0.58
2	Small Cargo Ship	0.47
3	Container Ship(Over Panamax)	0.42
4	Container(Panamax)	0.52
5	Very Large Bulk Carrier	0.52
6	Large Bulk Carrier(Panamax)	0.49
7	Small Bulk Carrier	0.62
8	VLCC	0.62
9	Small Tanker	0.60
10	LNG Ship	0.75
11	Refrigerated Cargo Carrier	0.63
12	Passenger Ship (2shafts 2propellers)	0.66
13	Ferry Boat (2shafts 1propellers)	0.55

Table G2-12: Non-dimensional index of turning ability ($K_R = K'$)

G2.8 Calculation of Drift Angle due to Wind Forces (Addendum)

G2.8.1 Drift Angle and Check Helm

The drift angle due to the wind forces β can be obtained theoretically by solving the equilibrium equations with respect to the drift angle and the check helm in the course keeping motion under the wind forces, which are derived from the coupled motion equations of sway and yaw [Inoue et al., 1981 ; SNAME, 1989]. The solutions of the above equilibrium equations (algebraic equations), namely the drift angle β and the check helm δ , can be given by the following equations:

$$\beta = \mu \frac{Y'_W(\theta_W)N'_\delta - N'_W(\theta_W)Y'_\delta}{Y'_V N'_\delta - N'_V Y'_\delta} \quad (G2-0)$$

$$\delta = \mu \frac{Y'_W(\theta_W)N'_V - N'_W(\theta_W)Y'_V}{Y'_V N'_\delta - N'_V Y'_\delta} \quad (G2-0)$$

G2.8.2 Linear Derivatives of Hull Forces and Rudder Forces

In Eqs. G2-27 and G2-28, Y'_V and N'_V denote the linear static derivatives of hull lateral force and hull yaw moment respectively and they can be estimated by the following equations [Ohtsu et al., 2006 ; SNAME, 1989] in which the shallow water effects are taken into consideration:

$$Y'_V (= Y'_V + \gamma Y'_\delta) = - \left[\frac{0.5\pi k}{0.5kd_H + \{0.5\pi d_H \cot(0.5\pi d_H)\}^{2.3}} + 1.4 \frac{C_B B}{L_{pp}} \right] + 0.4 Y'_\delta \quad (G2-0)$$

$$N'_V (= N'_V + \gamma N'_\delta) = - \left[\frac{\pi k}{0.5kd_H + \{0.5\pi d_H \cot(0.5\pi d_H)\}^{1.7}} \right] + 0.4 N'_\delta \quad (G2-0)$$

where:

$k (= 2T/L_{pp})$: aspect ratio of ship

L_{pp} : length of ship (between perpendiculars)

B : breadth of ship

T : draught of ship

C_B : block coefficient

$d_H (= T/h)$: ratio of ship draught to water depth

h : water depth

$\gamma (= 0.4)$: flow-straightening coefficient

In Eqs. G2-27 to G2-30, Y'_δ and N'_δ denote the linear derivative of rudder lateral force and rudder yaw moment respectively, and they can be estimated by the following equations [Ohtsu et al., 2006 ; SNAME, 1989]:

$$Y'_\delta = -\varepsilon(1 + a_H) \frac{6.13\lambda_R}{\lambda_R + 2.25} \cdot \frac{A_R}{L_{pp}T} \quad (G2-0)$$

$$N'_\delta = -0.5 Y'_\delta \quad (G2-0)$$

where λ_R : aspect ratio of rudder and A_R : rudder area.

In Eqs. G2-31 and G2-32, ε denotes the coefficient of rudder inflow speed and the followings are practically employed in the computation:

- $\varepsilon = 1.1$ for both ships with a single propeller and single rudder arrangement and with a twin propeller and twin rudder arrangement.
- $\varepsilon = 0.7$ for a ship with a twin propeller and single rudder arrangement.

In addition, a_H denotes the coefficient of hydrodynamic force induced on the ship hull by the rudder deflection, and a_H can be estimated with the use of Figure G2-9 given as a function of C_b [Kose et al., 1981].

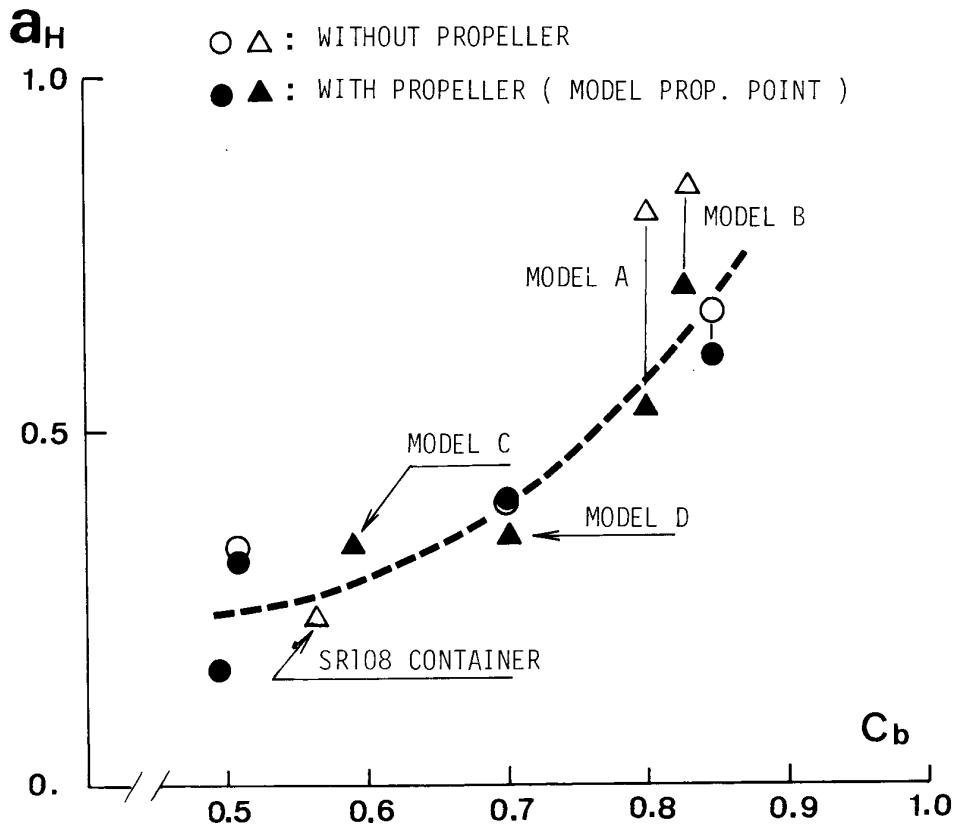

Figure G2-1: Hydrodynamic coefficient a_H

G2.8.3 Wind Force Coefficients

In Eqs. G2-27 and G2-28, the coefficient with respect to the wind forces μ is given in the following form:

$$\mu = \left(\frac{\rho_a}{\rho_w} \right) \left(\frac{A_{V,L}}{L_{pp} T} \right) \left(\frac{V_{WR}}{V_s} \right)^2 \quad (G2-0)$$

where:

ρ_a : density of air

ρ_w : density of water

$A_{V,L}$: projected lateral area above water line

V_{WR} : relative wind speed at centre of gravity of ship

V_s : ship speed.

In addition, $Y'_W(\theta_W)$ and $N'_W(\theta_W)$ denote the coefficients of wind lateral force and wind yaw moment respectively as functions of θ_W which indicates the angle of relative wind direction at the centre of gravity of the ship. On the basis of the wind tunnel experiments, $Y'_W(\theta_W)$ and $N'_W(\theta_W)$ may practically be obtained by the following expressions with the trigonometric series [Yamano and Saito, 1997]:

$$Y'_W(\theta_W) = \sum_{n=1}^3 C_{Yn} \sin(n\theta_W) \quad (G2-0)$$

$$N'_W(\theta_W) = 0.1 \sum_{n=1}^3 C_{Nn} \sin(n\theta_W) \quad (G2-0)$$

In the above equations, the regression coefficients C_{Yn} and C_{Nn} are estimated by the following equations, for which the coefficients C_{Yn0} , C_{Yn1} , C_{Nn0} , C_{Nn1} etc. are given in Table G2-13:

$$C_{Yn} = C_{Yn0} + C_{Yn1} \frac{A_{V,L}}{L_{pp}^2} + C_{Yn2} \frac{x_L}{L_{pp}} + C_{Yn3} \frac{L_{pp}}{B} + C_{Yn4} \frac{A_{V,L}}{A_{V,F}} \quad (G2-0)$$

$$C_{Nn} = C_{Nn0} + C_{Nn1} \frac{A_{V,L}}{L_{pp}^2} + C_{Nn2} \frac{x_L}{L_{pp}} + C_{Nn3} \frac{L_{pp}}{B} + C_{Nn4} \frac{A_{V,L}}{A_{V,F}} \quad (G2-0)$$

where:

$A_{V,F}$: projected front area above water line

$A_{V,L}$: projected lateral area above water line

x_L : distance between FP (fore perpendicular) and centre of $A_{V,L}$

Coefficient	Constant	$A_{V,L}/L_{pp}^2$	x_L/L_{pp}	L_{pp}/B	$A_{V,L}/A_{V,F}$
C_y Coefficients					
C_{y1}	0.509	4.904			0.022
C_{y2}	0.0208	0.23	-0.075		
C_{y3}	-0.357	0.943		0.0381	
C_m Coefficients					
C_{m1}	2.65	4.634	-5.876		
C_{m2}	0.105	5.306			0.0704
C_{m3}	0.616		-1.474	0.0161	

Table G2-13: Regression coefficients of wind forces

G2.9 Calculation of Check Helm against Interaction Forces (Addendum)

In the similar way to Section G2.8, the check helm δ against interaction forces can be obtained theoretically by solving the equilibrium equations with respect to the drift angle and the check helm in the course keeping motion under the interaction forces.

G2.9.1 Check Helm against Bank Effect Forces

The check helm against the bank effect forces δ together with the drift angle β can be given in a similar way to Eqs. G2-27 and G2-28 as:

$$\delta = \frac{Y_B'(\eta')N_v^{*'} - N_B'(\eta')Y_v^{*'}}{Y_v^{*'}N_\delta' - N_v^{*'}Y_\delta'} \quad (\text{G2-0})$$

$$\beta = \frac{Y_B'(\eta')N_\delta' - N_B'(\eta')Y_\delta'}{Y_v^{*'}N_\delta' - N_v^{*'}Y_\delta'} \quad (\text{G2-0})$$

where $\eta' = \eta/L$ (η : clearance between ship longitudinal centre line and bank wall)

In Eqs. G2-38 and G2-39, $Y_B'(\eta')$ and $N_B'(\eta')$ denote the coefficients of lateral force and yaw moment due to bank effects respectively. The coefficients of $Y_B'(\eta')$ and $N_B'(\eta')$ may practically be estimated with the use of computed results [Kijima and Lee, 2002] shown in Figure G2-10, where C_F and C_M as functions of $S_P (= \eta)$ in the ordinate denote $Y_B'(\eta')$ and $N_B'(\eta')$ respectively and S_T' in the abscissa denotes dimensionless distance (divided by the ship length) from the midship to the bank entrance in the longitudinal direction. It is noted that the peak values in the force and moment variations should be employed for the estimations of $Y_B'(\eta')$ and $N_B'(\eta')$ by Figure G2-10.

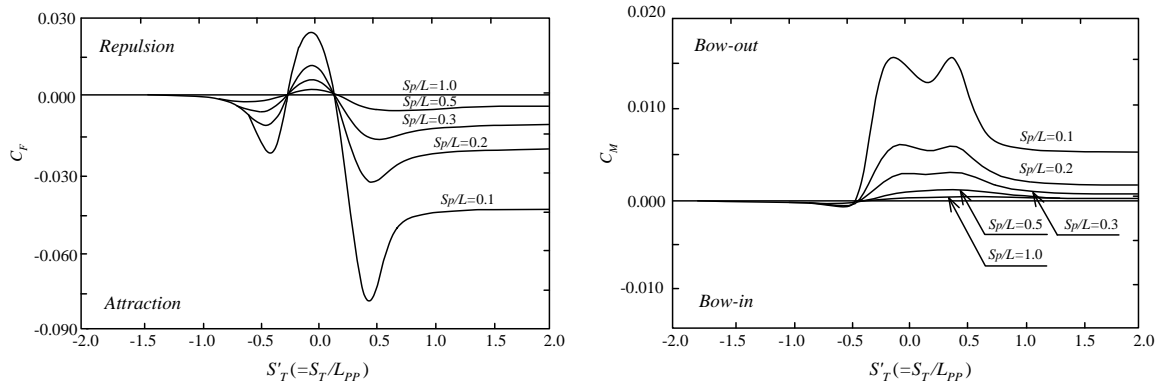
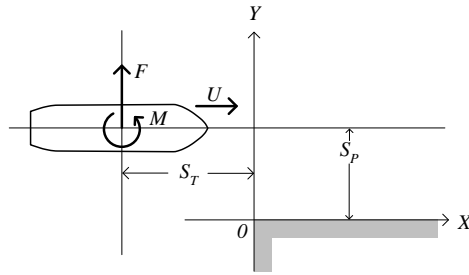

Figure G2-2: Lateral force and yaw moment due to bank effects

G2.9.2 Check Helm against Two-ship Interaction

The check helm against the two-ship interaction δ may be given by the following simple equation on the assumption of zero drift angle ($\beta = 0$) due to relatively short-time interaction:

$$\delta = -N_{Sl}'(\eta')/N_{\delta}' \quad (G2-0)$$

where:

$\eta' = \eta/L$ (η : clearance between longitudinal centrelines of two-ships)

The coefficient of yaw moment due to the two-ship interaction $N_{Sl}'(\eta')$ in Eq. G2-40 may practically be estimated with the use of computed results [Kijima and Lee, 2002] shown in Figures G2-11 and G2-12. In these figures, C_{Mi} ($i = 1,2$) as a function of $S_{P12}(\eta)$ in the ordinate denotes $N_{Sl}'(\eta')$ and S_{T12} in the abscissa denotes the midship to midship distance of two ships in the longitudinal direction. Figure G2-11 shows $N_{Sl}'(\eta')$ for the meeting condition and Figure G2-12 shows $N_{Sl}'(\eta')$ for the overtaking condition. In the similar way to the bank effect forces, it is noted that the peak value in the moment variation should be employed for the estimations of $N_{Sl}'(\eta')$ by Figure G2-11 and G2-12.

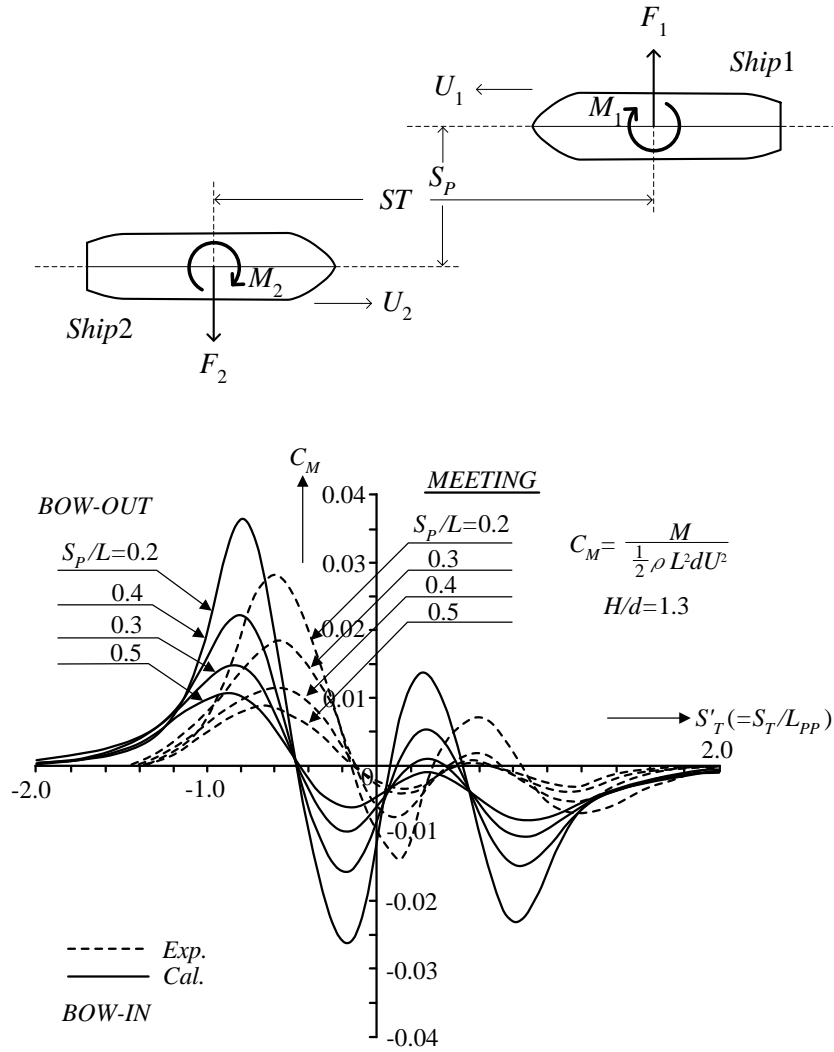

Figure G2-3: Yaw moment due to two-ship interaction in passing

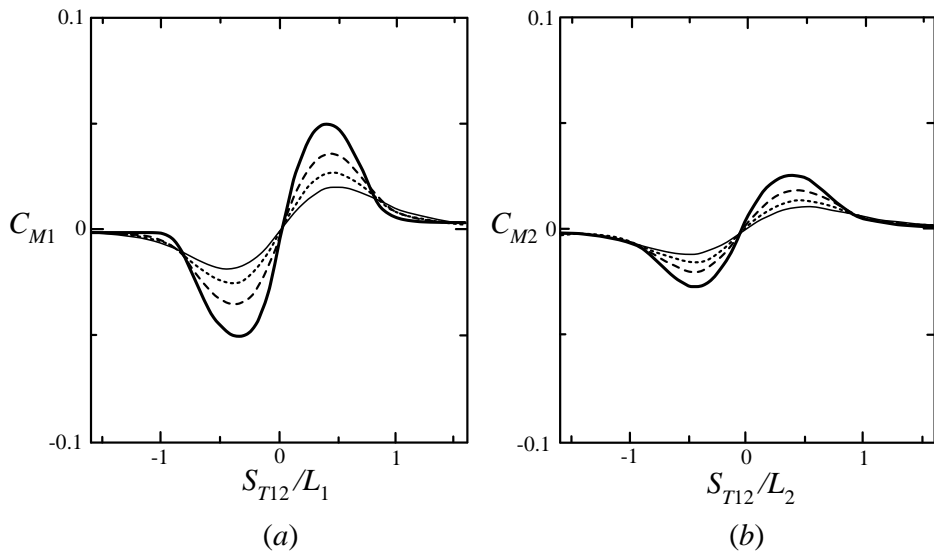
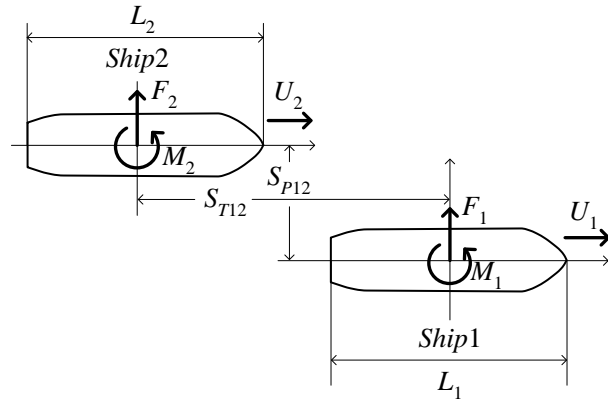

Figure G2-4: Yaw moment due to two-ship interaction in overtaking

15 G3: DETAILED JAPANESE FORMULAE ON WIND-WAVE-CURRENT EFFECTS VERSUS SHIP TYPE-SIZES

Dynamics of the ship manoeuvring motion may basically be represented with the use of horizontal motions of the surge, sway and yaw [Inoue et al., 1981 ; SNAME, 1989] on the assumption that coupling effects due to the heave, roll and pitch on the horizontal motions could be neglected. Ship manoeuvring motion generally has distinct features of high non-linearity with respect to motion variables. For this reason, at first, nonlinear motion equations of the coupled surge, sway and yaw are presented together with hydrodynamic forces, for which external forces (wind, wave and current) and forces acting on the ship hull and rudder are discussed in detail. The nonlinear motion equations play an important role for such a realistic prediction purpose as the use in the ship handling simulator. On the other hand, the linear approach is more desirable and useful for the fairway width design from a view point of practical application, because the ship handling in a channel may be mild by relatively small rudder (not a radical motion with large rudder). Focusing on the course keeping operation under wind forces, the linearised motion equations with respect to the sway and yaw are presented next, where the drift angle and the check helm at the equilibrium condition are calculated as a typical application of the linearised motion equations.

G3.1 Equations of Ship Manoeuvring Motion

Referring to the coordinate system shown in Figure G3-1, basic motion equations of the coupled surge, sway and yaw can be described in the following forms:

$$\text{Surge: } m(\dot{u} - vr) = X_H + X_P + X_R + X_{EX} \quad (\text{G3-0})$$

$$\text{Sway: } m(\dot{v} + ur) = Y_H + Y_R + Y_{EX} \quad (\text{G3-0})$$

$$\text{Yaw: } I_{zz}\dot{r} = N_H + N_R + N_{EX} \quad (\text{G3-0})$$

where:

m : mass of ship

I_{zz} : moment of inertia of ship with respect to z-axis

u : surge velocity in x-direction

v : sway velocity in y-direction

r : yaw angular velocity about z-axis (yaw rate).

In Eqs. G3-1 to G3-3, the terms with subscripts H and R represent the hull forces (the hydrodynamic forces generated by ship motion and acting on the ship hull) and the rudder forces respectively. The terms with subscript EX represent external forces such as the wind forces, interaction forces due to the bank wall and so on. The symbol X_P in Eq. G3-1 denotes the propeller thrust.

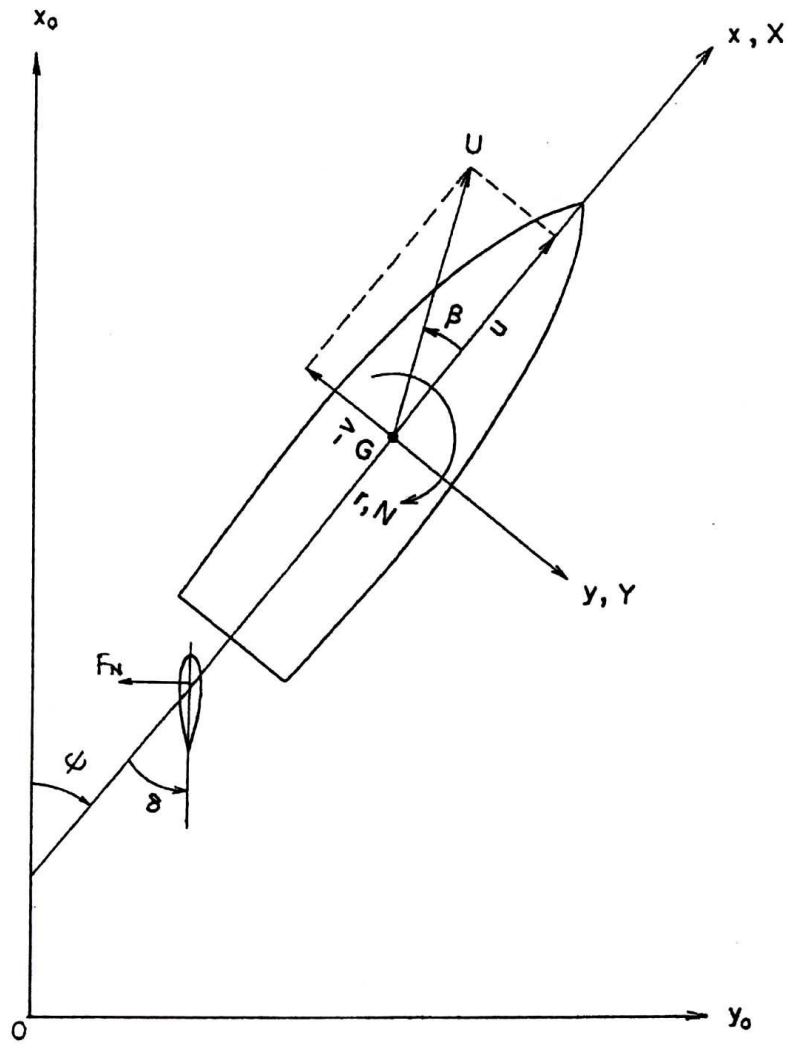

Figure G3-1: Coordinate system of ship manoeuvring motion

G3.2 Wind Forces

See also OSIMF 6.4 Oil Companies International Marine Forum and SIGTTO, Society of International Gas Tanker and Terminal Operators.

G3.2.1 Representations of Wind Forces

Referring to the coordinate system shown in Figure G3-1, X_W (the wind longitudinal force in x-direction), F_{Wy} (the wind lateral force in y-direction) and N_W (the wind yaw moment about z-axis) may be represented by the following equations (see also OSIMF 6.4 and SIGTTO Society of International Gas Tanker and Terminal Operators):

$$X_W = X_W'(\theta_W) \cdot (1/2) \rho_a A_{V,F} V_{WR}^2 \quad (G3-0)$$

$$Y_W = Y_W'(\theta_W) \cdot (1/2) \rho_a A_{V,L} V_{WR}^2 \quad (G3-0)$$

$$N_W = N_W'(\theta_W) \cdot (1/2) \rho_a A_{V,L} L_{pp} V_{WR}^2 \quad (G3-0)$$

where:

θ_W : angle of relative wind direction

V_{WR} : relative wind speed

ρ_a : density of air

$A_{V,F}$: projected front area above water line

$A_{V,L}$: projected side area above water line

L_{pp} : length of ship (between perpendiculars).

G3.2.2 Estimations of Wind Force Coefficients

Wind force coefficients are usually estimated by regression equations with variables related to the configuration of ship superstructure above the water line, which are developed on the basis of wind tunnel experiments. An estimation method developed by Yamano et al. (1997) is available and useful from a view point of practical application and they are given as:

$$X_W'(\theta_W) = \sum_{n=0}^5 C_{Xn} \cos(n\theta_W) \quad (G3-0)$$

$$Y_W'(\theta_W) = \sum_{n=1}^3 C_{Yn} \sin(n\theta_W) \quad (G3-0)$$

$$N_W'(\theta_W) = 0.1 \sum_{n=1}^3 C_{Nn} \sin(n\theta_W) \quad (G3-0)$$

In Eqs. G3-7 to G3-9, regression coefficients C_{Xn} , C_{Yn} and C_{Nn} are estimated by the following expressions, for which values of the coefficients C_{Xn0} , C_{Xn1} , C_{Yn0} , C_{Yn1} , C_{Nn0} , C_{Nn1} etc. are given in Table G3-1:

$$C_{Xn} = C_{Xn0} + C_{Xn1} \frac{A_{V,L}}{L_{pp}^2} + C_{Xn2} \frac{x_L}{L_{pp}} + C_{Xn3} \frac{L_{pp}}{B} + C_{Xn4} \frac{A_{V,L}}{A_{V,F}} \quad n=0-5 \quad (G3-0)$$

$$C_{Yn} = C_{Yn0} + C_{Yn1} \frac{A_{V,L}}{L_{pp}^2} + C_{Yn2} \frac{x_L}{L_{pp}} + C_{Yn3} \frac{L_{pp}}{B} + C_{Yn4} \frac{A_{V,L}}{A_{V,F}} \quad n=1-3 \quad (G3-0)$$

$$C_{Nn} = C_{Nn0} + C_{Nn1} \frac{A_{V,L}}{L_{pp}^2} + C_{Nn2} \frac{x_L}{L_{pp}} + C_{Nn3} \frac{L_{pp}}{B} + C_{Nn4} \frac{A_{V,L}}{A_{V,F}} \quad n=1-3 \quad (G3-0)$$

where x_L : distance between FP (fore perpendicular) and centre of $A_{V,L}$.

Coefficient	Constant	$A_{V,L}/L_{pp}^2$	X_L/L_{pp}	L_{pp}/B	$A_{V,L}/A_{V,F}$
C_x Coefficients					
C_{x0}	-0.0358	0.925	0.0521		
C_{x1}	2.58	-6.087		-0.1735	
C_{x2}	-0.97		0.978	0.0556	
C_{x3}	-0.146			-0.0283	0.0728
C_{x4}	0.0851			-0.0254	0.0212
C_{x5}	0.0318	0.287		-0.0164	
C_y Coefficients					
C_{y1}	0.509	4.904			0.022
C_{y2}	0.0208	0.23	-0.075		
C_{y3}	-0.357	0.943		0.0381	
C_m Coefficients					
C_{m1}	2.65	4.634	-5.876		
C_{m2}	0.105	5.306			0.0704
C_{m3}	0.616		-1.474	0.0161	

Table G3-1: Regression coefficients of wind forces

G3.3 Wave Forces

Wave exciting forces generally consist of two basic components. One is the forces, as the 1st order component, oscillating periodically with the encounter wave frequency. This oscillatory forces cause the wave induced motion such as the yawing. The other is the wave drifting forces, the steady forces as the 2nd order component. This wave drifting forces act steadily which result in the sway and yaw displacements similarly to the wind effects.

G3.3.1 Lateral Deviation due to Yawing Motion

The 1st-order oscillatory forces may not affect the motion trajectory if an ideal condition of simple harmonic oscillation which results in the zero movement of sway and yaw as the mean value. However, in the sea of irregular waves, the ship generally makes yawing motion caused by unsteady wave forces. The yawing motion (angle) $\psi(t)$ may be given as:

$$\psi(t) = \psi_0 \sin\left(\frac{2\pi}{T_y} t\right) \quad (G3-0)$$

where:

ψ_0 : yawing amplitude

T_y : yawing period

The maximum amplitude of lateral deviation due to this yawing motion D_Y can be calculated with the use of Eq. G3-13 as:

$$D_Y = \int_{t=0}^{t=\frac{T_y}{4}} V_s \sin \psi(t) dt = V_s \int_{t=0}^{t=\frac{T_y}{4}} \sin \left[\psi_0 \sin\left(\frac{2\pi}{T_y} t\right) \right] dt = \frac{1}{4} V_s T_y \sin \psi_0 \quad (G3-0)$$

G3.3.2 Representations of Wave Drifting Forces

Referring to the coordinate system shown in Figure G3-1, X_{WV} (the wave drifting longitudinal force in x-direction), Y_{WV} (the wave drifting lateral force in y-direction) and N_{WV} (the wave drifting yaw moment about z-axis) may be represented by the following equations:

$$X_{WV} = X'_{WV}(\lambda/L_{pp}, \psi_{WV}) \cdot (1/2) \rho_w g L_{pp} a_w^2 \quad (G3-0)$$

$$Y_{WV} = Y'_{WV}(\lambda/L_{pp}, \psi_{WV}) \cdot (1/2) \rho_w g L_{pp} a_w^2 \quad (G3-0)$$

$$N_{WV} = N'_{WV}(\lambda/L_{pp}, \psi_{WV}) \cdot (1/2) \rho_w g L_{pp}^2 a_w^2 \quad (G3-0)$$

where:

λ : wave length

ψ_{WV} : wave direction

a_w : wave amplitude (= a half of wave height).

ρ_w : density of water

The coefficients of wave drifting forces X'_{WV} , Y'_{WV} and N'_{WV} are negligibly small in long wave region of $\lambda/L_{pp} > 1.0$. However, they increase considerably as λ/L_{pp} decreases, and possess peaks in the region of fairly short wave length of $\lambda/L_{pp} < 0.5$ [Hirano et al., 1980] which may not be ignorable depending on wave conditions.

G3.4 Current Forces

As mentioned in the above sections, the wind and wave effects are generally evaluated on the basis of the forces acting on the ship. On the other hand, the current effects may usually be examined by a different approach from that of wind and wave effects. For simplicity, let us discuss current effects on the course keeping operation under the condition with spatially uniform current velocity. The current forces generally influence the ship manoeuvring motion similarly to the wind forces. However, in the spatially uniform current, the ship is simply brought down in the current direction with the current velocity. For this reason, the ship can advance on the straight course of fairway by running obliquely with rudder amidships up to the current to cancel the current velocity perpendicular to the ship course line. Meanwhile, in the course keeping motion under wind forces, rudder deflections are needed as the check helm to counterbalance the bow-up moments generated by both the wind forces acting on the ship superstructure and the hydrodynamic forces acting on the ship hull.

As additional remarks, the followings are noted with respect to the motion calculation. The motion equations of ship manoeuvring are basically described with respect to the ship speed relative to water (not relative to the earth). In this sense, current forces should not be taken into account in motion equations in the case of spatially uniform current condition. The ship speed relative to the earth can be obtained by the vector calculation of ship speed relative to water and uniform current velocity. In the current with spatially distributed velocity, effects of the shear flow may be considered depending on the magnitude of velocity gradient.

G3.5 Hull Forces and Rudder Forces

The hull forces and rudder forces in the right-hand side of motion equations are generally represented by complicated nonlinear functions of such motion variables as velocity, acceleration, rudder angle and so on. Hydrodynamic force expressions are usually named as the mathematical model, and key points of them are summarised in the followings.

G3.5.1 Hull Forces

The hull forces (the hydrodynamic forces acting on the ship hull caused by its manoeuvring motion) X_H (the longitudinal force), Y_H (the lateral force) and N_H (the yaw moment) are given in the following forms:

$$X_H = -m_x \dot{u} + (m_y + X_{vr})vr + X(u) \quad (G3-0)$$

$$Y_H = -m_y \dot{v} - m_x ur + (1/2) \rho_w L_{pp} TV_s^2 \left[Y'_v v' + Y'_r r' + \text{nonlinear terms} \right] \quad (G3-0)$$

$$N_H = -J_{zz} \dot{r} + (1/2) \rho_w L_{pp}^2 TV_s^2 \left[N'_v v' + N'_r r' + \text{nonlinear terms} \right] \quad (G3-0)$$

where:

$V_s (= \sqrt{u^2 + v^2})$: ship speed

$v' = v/V_s = -\sin \beta$ (β : drift angle)

$r' = rL_{pp}/V_s$

m_x, m_y : added mass of ship in x- and y-direction respectively

J_{zz} : added moment of inertia of ship with respect to z-axis

$X(u)$: ship resistance

L_{pp} : length of ship (between perpendiculars)

T : draught of ship

G3.5.2 Rudder Forces

The rudder forces X_R (the longitudinal force), Y_R (the lateral force) and N_R (the yaw moment) are given in the following forms:

$$X_R = -F_{NR} \sin \delta_R \quad (G3-0)$$

$$Y_R = -(1 + a_H) F_{NR} \cos \delta_R \quad (G3-0)$$

$$N_R = -(1 + a_H) x_R F_{NR} \cos \delta_R \quad (G3-0)$$

where:

F_{NR} : rudder normal force

δ_R : rudder angle

In the above equations for rudder forces, hydrodynamic force induced on the ship hull by rudder deflection is considered and denoted with a form of $a_H F_{NR} \cos \delta_R$. The rudder normal force F_{NR} may be written as:

$$F_{NR} = (1/2) \rho_w C_R A_R U_R^2 \sin \alpha_R \quad (G3-0)$$

where:

$C_R (= 6.13\lambda_R/(\lambda_R + 2.25))$: normal force coefficient of rudder (lift slope)

λ_R : aspect ratio of rudder

A_R : rudder area

U_R : effective rudder inflow velocity

α_R : effective rudder inflow angle (effective attack angle)

The effective rudder inflow angle α_R may be represented in consideration of flow straightening effects due to both ship hull and propeller as:

$$\alpha_R = \delta - \gamma(\beta - 2x_R' r') \quad (\text{G3-0})$$

where:

γ : flow straightening coefficient

$x_R' = 2x_R/L_{pp}$ (x_R : x-coordinate of rudder position)

G3.6 Linearised Motion Equations

Assuming that the sway velocity v and yaw rate r are sufficiently small comparing with the ship speed V_s together with $u \approx V_s$ for the surge velocity, the equations of ship manoeuvring motion given in Eqs. G3-1 to G3-3 are linearised and then the coupled equations of sway and yaw are derived where the surge equation is decoupled.

G3.6.1 Linearisation of Hydrodynamic Forces

The sway and yaw hull forces are easily linearised from Eqs. G3-19 and G3-20 as:

$$Y_H = -m_y \dot{v} - m_x ur + (1/2) \rho_w L_{pp} T V_s^2 [Y_v' v' + Y_r' r'] \quad (\text{G3-0})$$

$$N_H = -J_{zz} \dot{r} + (1/2) \rho_w L_{pp}^2 T V_s^2 [N_v' v' + N_r' r'] \quad (\text{G3-0})$$

The sway and yaw rudder forces may be linearised from Eqs. G3-22 to G3-25 as follows, where assumptions of $\sin \alpha_R \approx \alpha_R$ and $\cos \delta = 1$ are made:

$$Y_R = (1/2) \rho_w L_{pp} T V_s^2 Y_\delta' [\delta - \gamma(\beta + r')] \quad (\text{G3-0})$$

$$N_R = (1/2) \rho_w L_{pp}^2 T V_s^2 N_\delta' [\delta - \gamma(\beta + r')] \quad (\text{G3-0})$$

where:

$$Y_\delta' = -\varepsilon(1 + a_H) [6.13\lambda_R/(\lambda_R + 2.25)] [A_R/(L_{pp} T)] \quad (\text{G3-0})$$

$$N_\delta' = -\varepsilon(1 + a_H) x_R' [6.13\lambda_R/(\lambda_R + 2.25)] [A_R/(L_{pp} T)] \approx -0.5Y_\delta' \quad (\text{G3-0})$$

$$\varepsilon = (U_R/V_s)^2 \quad (\text{G3-0})$$

The square of the ratio of effective rudder inflow velocity to ship speed ε and the flow straightening coefficient γ in the above expressions are generally given by complicated

functions of motion variables with high nonlinearity. However, it may be assumed that both ε and γ are to be kept constant in the manoeuvring motion by small rudder.

G3.6.2 Linearised Sway and Yaw Equations

Substituting Eqs. G3-26 to G3-29 into Eqs. G3-2 and G3-3 and non-dimensionalising the sway equation with $(1/2)\rho L_{pp}TV_s^2$ and the yaw equation with $(1/2)\rho L_{pp}^2TV_s^2$, then the linearised sway and yaw equations can be obtained in the following forms:

$$\text{Sway: } (m' + m_y')\dot{v}' - Y_v'v' - Y_r'r' = Y_\delta'\delta + Y_{EX}'/[1/2\rho_w L_{pp}TV_s^2] \quad (\text{G3-0})$$

$$\text{Yaw: } (I_{zz}' + J_{zz}')\dot{r}' - N_r'r' - N_v'v' = N_\delta'\delta + N_{EX}'/[(1/2)\rho_w L_{pp}^2TV_s^2] \quad (\text{G3-0})$$

where:

$$Y_v' = Y_v' + \gamma Y_\delta'$$

$$Y_r' = Y_r' - (m' + m_x') - \gamma Y_\delta'$$

$$N_v' = N_v' + \gamma N_\delta'$$

$$N_r' = N_r' - \gamma N_\delta'.$$

In the above equations, the last terms with γ in the right-hand side represent fin effects on the ship hull due to the rudder of no deflection.

G3.6.3 Estimation of Linear Hull Force Derivatives

The linear hull force derivatives can be obtained with sufficient accuracy using the practical formulae [Inoue et al., 1981 ; SNAME, 1989], in which the shallow water effects are taken into consideration:

$$Y_v' = -(0.5\pi k_e + 1.4C_B B/L_{pp})(1 + 0.67\tau') \quad (\text{G3-0})$$

$$Y_r' = 0.25\pi k_e (1 + 0.80\tau') \quad (\text{G3-0})$$

$$N_v' = -k_e (1 - \tau') \quad (\text{G3-0})$$

$$N_r' = -(0.54k_e - k_e^2)(1 + 0.30\tau') \quad (\text{G3-0})$$

with

$$k_e = \frac{k}{0.5kd_H + [0.5\pi d_H \cot(0.5\pi d_H)]^2} \quad (\text{G3-0})$$

where:

$k = 2T/L_{pp}$: aspect ratio of ship

$d_H = T/h$ (h : water depth)

$\tau' = \tau/T_m$ (τ : trim, T_m : mean of fore and aft draught)

B : breadth of ship

C_B : block coefficient

λ : experimental constant

($\lambda = 2.3$ for Y_v' , $\lambda = 1.7$ for N_v' and $\lambda = 0.7$ for Y_δ' and N_δ')

G3.7 Drift Angle and Check Helm in Course Keeping Motion under Wind Forces

G3.7.1 Equilibrium Equations

Assuming $\dot{v}' = \dot{r}' = r' = 0$ in Eqs. G3-33 and G3-34 and substituting the wind forces of F_{WY} and N_W given in Eqs. G3-5 and G3-6 into the terms of Y_{EX} and N_{EX} in Eqs. G3-33 and G3-34 respectively, then the equilibrium equations for the course keeping motion under wind forces can be derived, which are written as:

$$\text{Sway: } Y_v'^* v' + Y_\delta' \delta + \mu Y_W'(\theta_W) = 0 \quad (\text{G3-0})$$

$$\text{Yaw: } N_v'^* v' + N_\delta' \delta + \mu N_W'(\theta_W) = 0 \quad (\text{G3-0})$$

where:

$$\mu = (\rho_a / \rho_w) [A_{V,L} / (L_{pp} T)] (V_{WR} / V_s)^2.$$

G3.7.2 Drift Angle and Check Helm

Solving Eqs. G3-40 and G3-41 algebraically with respect to v' and δ , then the drift angle β and the rudder angle δ_R at the equilibrium condition in the course keeping operation under wind forces are obtained as:

$$\beta \approx -v' = \mu \frac{Y_W'(\theta_W) N_\delta' - N_W'(\theta_W) Y_\delta'}{Y_v'^* N_\delta' - N_v'^* Y_\delta'} \quad (\text{G3-0})$$

$$\delta_R = \mu \frac{Y_W'(\theta_W) N_v'^* - N_W'(\theta_W) Y_v'^*}{Y_v'^* N_\delta' - N_v'^* Y_\delta'} \quad (\text{G3-0})$$



Cover pictures:

A: Portsmouth Harbour, United Kingdom

B: © Le Havre Port, France

*PIANC Secrétariat Général
Boulevard du Roi Albert II 20, B 3
B-1000 Bruxelles
Belgique*

*<http://www.pianc.org>
VAT BE 408-287-945*

ISBN 978-2- 87223-205-5
EAN 9782872232055



9 78-2-87223-210-9